

SPECIFICATIONS

PARAMETERS	VALUES	UNITS
RATED VOLTAGE	3	Vp-p
OPERATING VOLTAGE RANGE	3 ~ 4.5	Vp-p
RATED CURRENT (MAX)	90	mA
COIL RESISTANCE	18 ± 3	OHM
MINIMUM SPL @ 10 CM	87	dB
RESONANT FREQUENCY	2,700 ± 500	Hz
OPERATING TEMPERATURE	-40 ~ +85	°C
STORAGE TEMPERATURE	-50 ~ +85	°C
HOUSING MATERIAL	PA46	-
TERMINAL MATERIAL	Sn PLATED PHOSPHOR BRONZE	-
WEIGHT	1	grams

THIS DOCUMENT CONTAINS DATA PROPRIETARY TO PROJECTS UNLIMITED, INC. ANY USE OR REPRODUCTION, IN ANY FORM, WITHOUT PRIOR WRITTEN PERMISSION OF PROJECTS UNLIMITED, INC. IS PROHIBITED.
©2003, Projects Unlimited Inc.

REVISION HISTORY

LTR	DESCRIPTION	DATE	APPROVED
-	RELEASED FROM ENGINEERING	2/10/2006	
A	REVISED TO INVENTOR 3-D DRAWING TEMPLATE	5/7/2010	B.R.

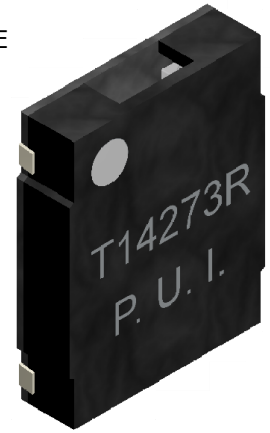
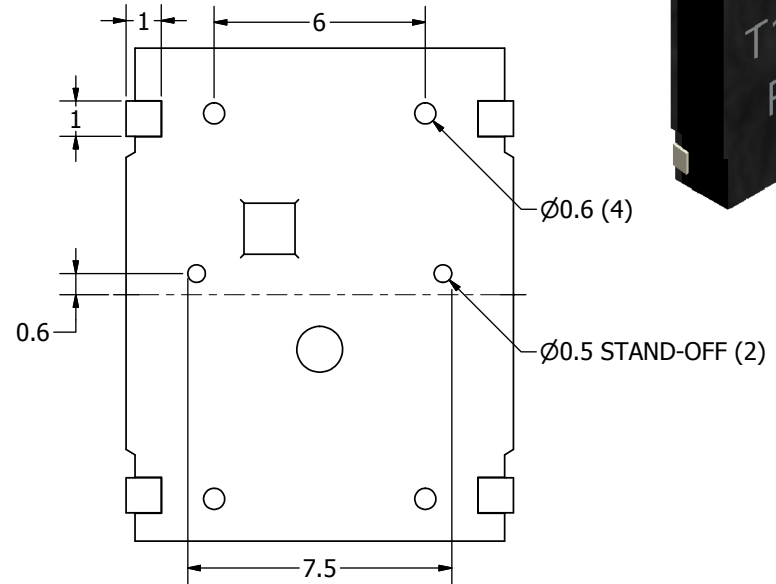
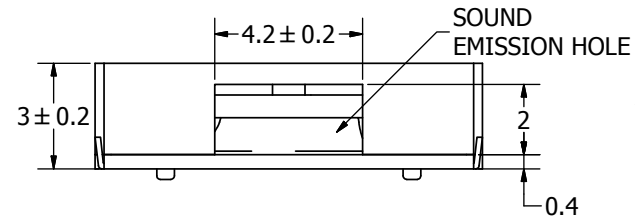
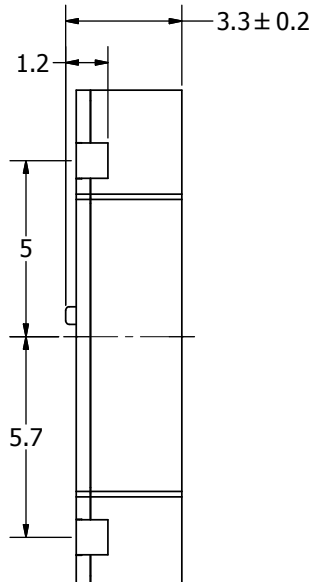
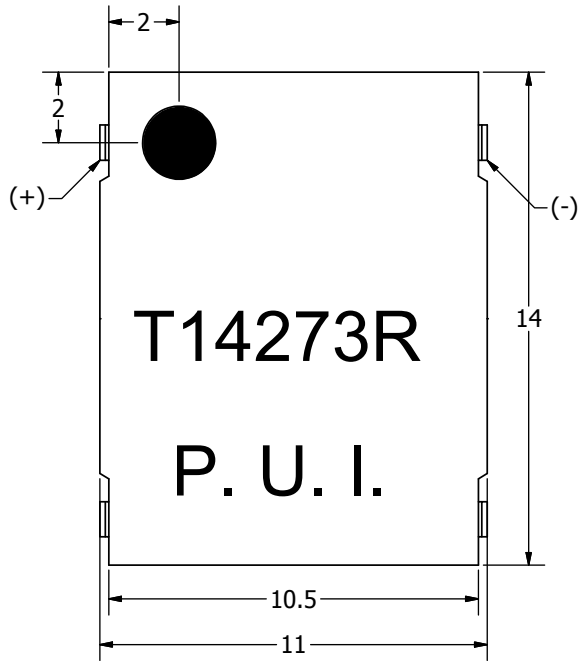

NOTES:

1. ALL DIMENSIONS ARE IN MILLIMETERS.
2. SPECIFICATIONS SUBJECT TO CHANGE OR WITHDRAWAL WITHOUT NOTICE.
3. THIS PART IS RoHS 2002/95/EC COMPLIANT.

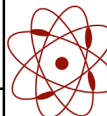
UNLESS OTHERWISE SPECIFIED: DIMENSIONS ARE IN MILLIMETERS, TOLERANCES ARE ±0.5 AND ANGLES ARE ±3°.	SIZE A3	Designed by	Date	Checked by	Date	Approved by	Date	Drawn Date
		J.A.F.	2/10/2006	E.P.	2/10/2006	B.R.	2/10/2006	5/7/2010
SMT-1427-S-3-R.idw		 pui audio a projects unlimited company				SMT-1427-S-3-R		
Transducer (Electro-Mech)						Edition	Sheet	
						-	1 / 1	