

SPECIFICATIONS

PARAMETERS	VALUES	UNIT
RATED VOLTAGE	5	Vp-p
OPERATING VOLTAGE RANGE	4 ~ 7	Vp-p
RATED CURRENT (MAX)	90	mA
COIL RESISTANCE	43 ± 6.5	OHM
MINIMUM SPL @ 10 CM	87	dB
RESONANT FREQUENCY	2,700 ± 500	Hz
OPERATING TEMPERATURE	-40 ~ +85	°C
STORAGE TEMPERATURE	-50 ~ +85	°C
HOUSING MATERIAL	LCP	-
TERMINAL MATERIAL	Sn PLATED PHOSPHOR BRONZE	-
WEIGHT	1	grams

THIS DOCUMENT CONTAINS DATA PROPRIETARY TO PROJECTS UNLIMITED, INC. ANY USE OR REPRODUCTION, IN ANY FORM, WITHOUT PRIOR WRITTEN PERMISSION OF PROJECTS UNLIMITED, INC. IS PROHIBITED.
©2003, Projects Unlimited Inc.

REVISION HISTORY

LTR	DESCRIPTION	DATE	APPROVED
-	RELEASED FROM ENGINEERING	9/27/2005	
A	REVISED TO INVENTOR 3-D DRAWING TEMPLATE	5/7/2010	B.R.

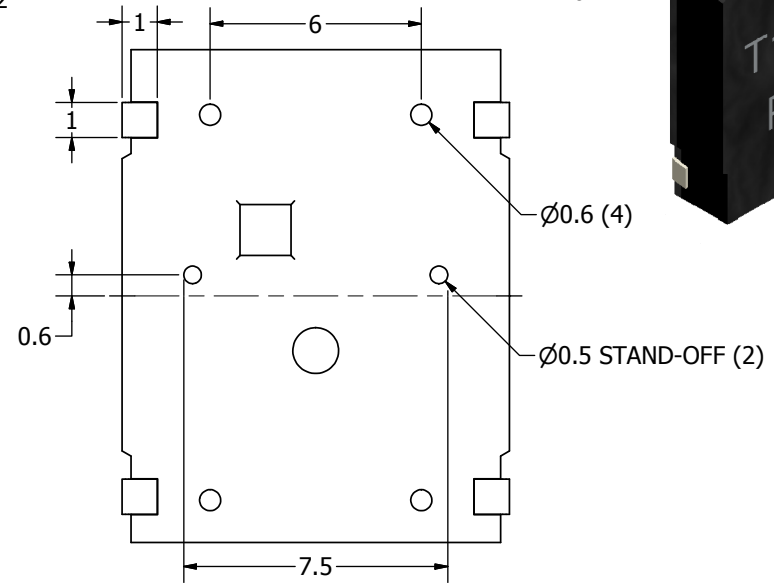
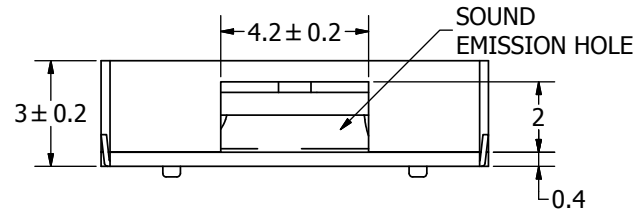
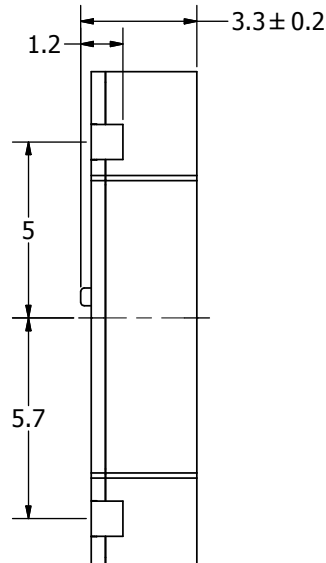
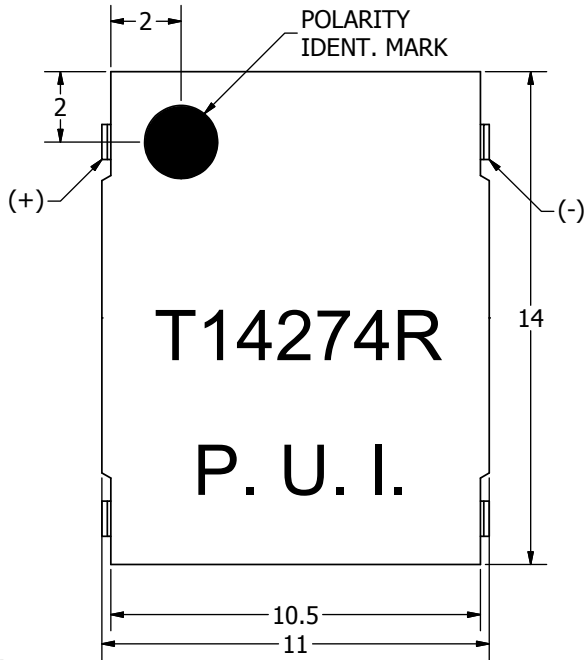

NOTES:

- ALL DIMENSIONS ARE IN MILLIMETERS.
- SPECIFICATIONS SUBJECT TO CHANGE OR WITHDRAWL WITHOUT NOTICE.
- THIS PART IS RoHS 2002/95/EC COMPLIANT.

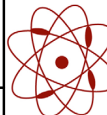
UNLESS OTHERWISE SPECIFIED: DIMENSIONS ARE IN MILLIMETERS, TOLERANCES ARE ±0.5 AND ANGLES ARE ±3°.	SIZE	Designed by	Date	Checked by	Date	Approved by	Date	Drawn Date
	A3	J.A.F.	9/27/2005	B.R.	9/27/2005	E.P.	9/27/2005	4/17/2008
SMT-1427-S-4-R.idw		 pui audio <small>a projects unlimited company</small>		SMT-1427-S-4-R Transducer (Electro-Mech)			Edition	Sheet
						-	1 / 1	