

SPECIFICATIONS

PARAMETERS	VALUES	UNITS
RATED VOLTAGE	5	Vp-p
OPERATING VOLTAGE RANGE	3 ~ 7	Vp-p
RATED CURRENT (MAX)	80	mA
COIL RESISTANCE	30 ± 4.5	OHM
MINIMUM SPL @ 10 CM	85	dB
RESONANT FREQUENCY	2,700 ± 500	Hz
OPERATING TEMPERATURE	-30 ~ +60	°C
STORAGE TEMPERATURE	-40 ~ +85	°C
HOUSING MATERIAL	LCP	-
TERMINAL MATERIAL	Sn PLATED PHOSPHOR BRONZE	-
WEIGHT	0.7	grams

THIS DOCUMENT CONTAINS DATA PROPRIETARY TO PROJECTS UNLIMITED, INC. ANY USE OR REPRODUCTION, IN ANY FORM, WITHOUT PRIOR WRITTEN PERMISSION OF PROJECTS UNLIMITED, INC. IS PROHIBITED.
©2003, Projects Unlimited Inc.

REVISION HISTORY

LTR	DESCRIPTION	DATE	APPROVED
-	RELEASED FROM ENGINEERING	5/4/2006	
A	REVISED TO INVENTOR 3-D DRAWING TEMPLATE	5/11/2010	B.R.

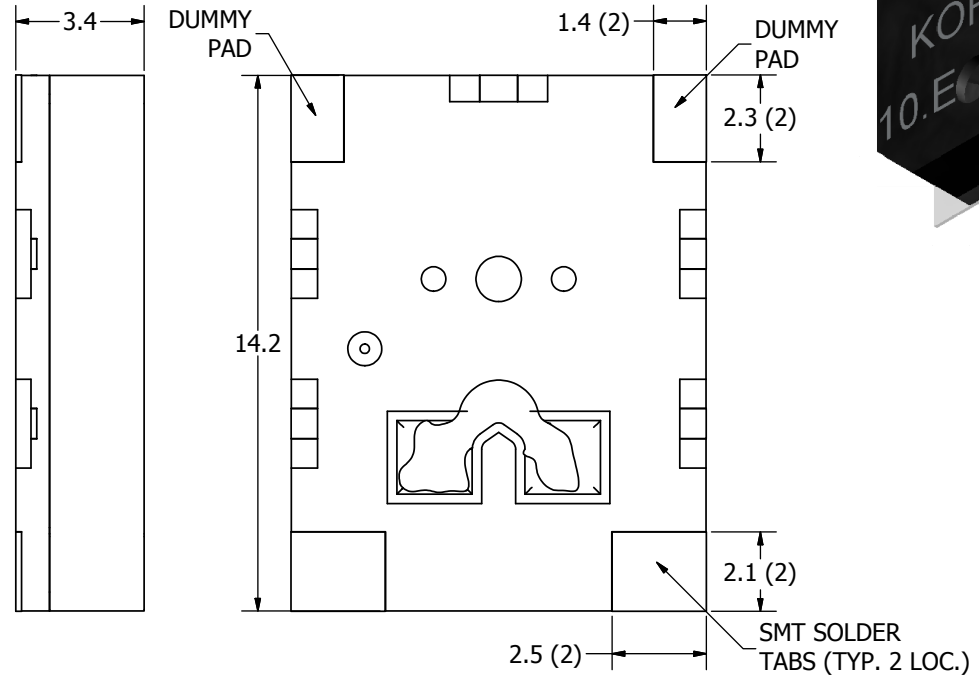
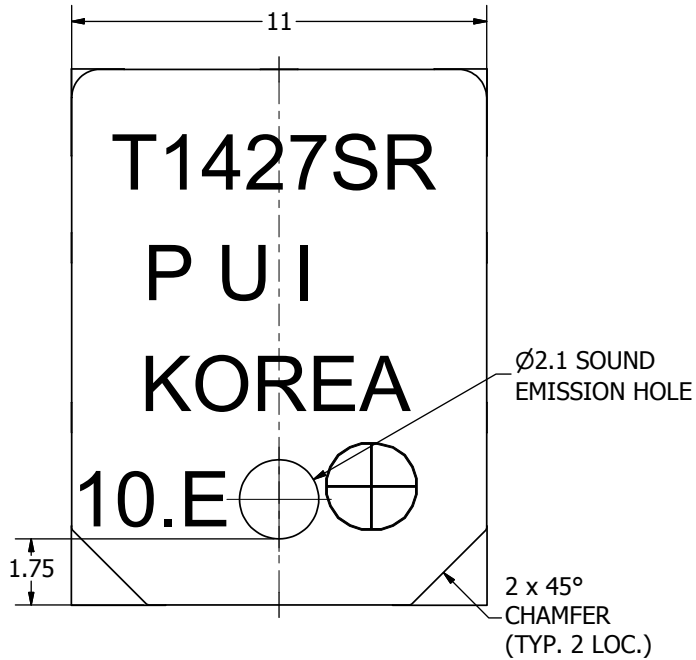

NOTES:

1. ALL DIMENSIONS ARE IN MILLIMETERS.
2. SPECIFICATIONS SUBJECT TO CHANGE OR WITHDRAWAL WITHOUT NOTICE.
3. THIS PART IS RoHS 2002/95/EC COMPLIANT.

UNLESS OTHERWISE SPECIFIED: DIMENSIONS ARE IN MILLIMETERS, TOLERANCES ARE ±0.5 AND ANGLES ARE ±3°.	SIZE	Designed by	Date	Checked by	Date	Approved by	Date	Drawn Date		
	A3	J.D.	5/4/2006	E.P.	5/4/2006	B.R.	5/4/2006	5/11/2010		
SMT-1427-T-R.idw						SMT-1427-T-R Transducer (Electro-Mech)			Edition	Sheet