

SPECIFICATIONS

PARAMETERS	VALUES	UNITS
RATED VOLTAGE	10	Vp-p
OPERATING VOLTAGE RANGE	1 ~ 30	Vp-p
RATED CURRENT (MAX)	3	mA
CAPACITANCE	19,000 ± 30%	pF
MINIMUM SPL @ 10 CM	90	dB
RESONANT FREQUENCY	4,000 ± 500	Hz
OPERATING TEMPERATURE	-20 ~ +70	°C
STORAGE TEMPERATURE	-30 ~ +80	°C
HOUSING MATERIAL	PPS	-
TERMINAL MATERIAL	Sn PLATED COPPER	-
WEIGHT	3	grams

THIS DOCUMENT CONTAINS DATA PROPRIETARY TO PROJECTS UNLIMITED, INC. ANY USE OR REPRODUCTION, IN ANY FORM, WITHOUT PRIOR WRITTEN PERMISSION OF PROJECTS UNLIMITED, INC. IS PROHIBITED.
©2003, Projects Unlimited Inc.

REVISION HISTORY

LTR	DESCRIPTION	DATE	APPROVED
-	RELEASED FROM ENGINEERING	12/5/2005	
A	REVISED CAPACITANCE	11/4/2009	B.R.
B	REVISED TO INVENTOR 3-D DRAWING TEMPLATE	5/12/2010	B.R.

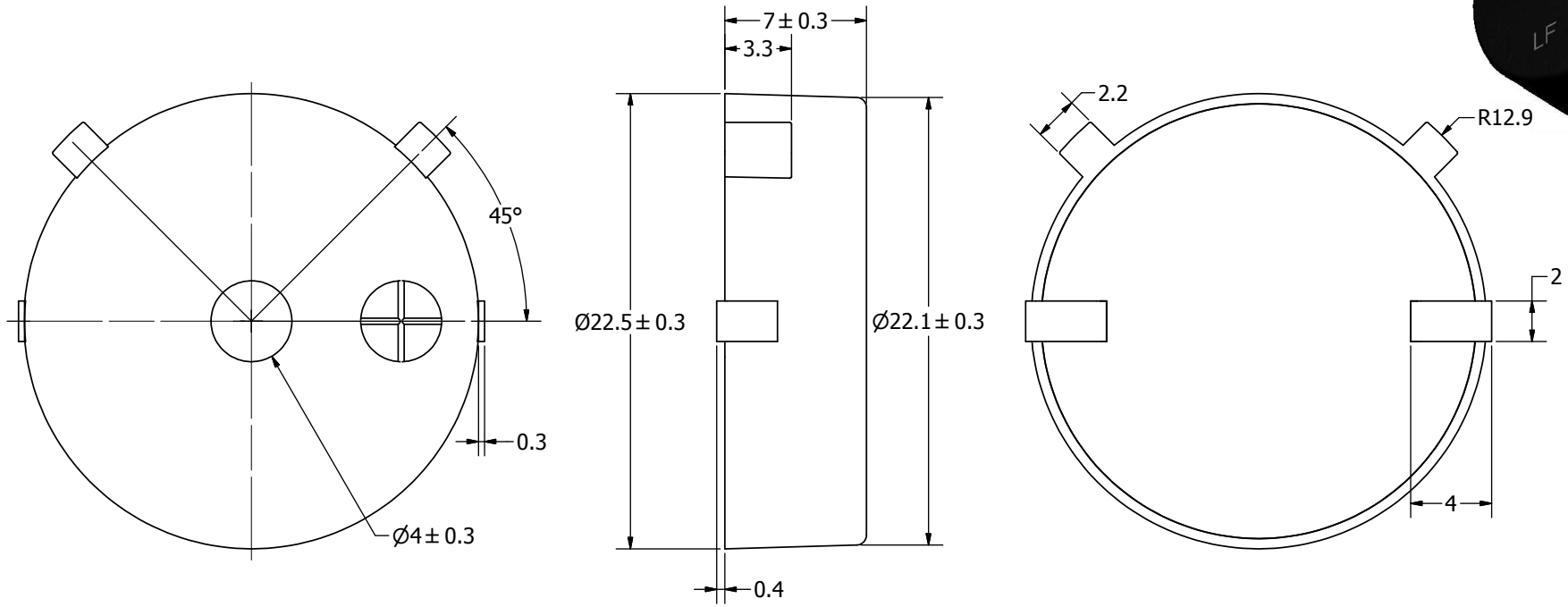

NOTES:

1. ALL DIMENSIONS ARE IN MILLIMETERS.
2. SPECIFICATIONS SUBJECT TO CHANGE OR WITHDRAWL WITHOUT NOTICE.
3. THIS PART IS RoHS 2002/95/EC COMPLIANT.

UNLESS OTHERWISE SPECIFIED: DIMENSIONS ARE IN MILLIMETERS, TOLERANCES ARE ±0.5 AND ANGLES ARE ±3°.	SIZE	Designed by	Date	Checked by	Date	Approved by	Date	Drawn Date
	A3	J.A.F.	12/5/2005	B.R.	12/5/2005	E.P.	12/5/2005	5/12/2010
SMT-2240-TW-R.idw						SMT-2240-TW-R		
Transducer (Piezo)						Edition	Sheet	
						-	1 / 1	