



L2044

LINEAR INTEGRATED CIRCUIT

DUAL OUTPUT FLASHER

DESCRIPTION

The UTC **L2044** is a dual output stages flasher designed as a relay driver for flashing light control in automotive applications. Both sides direction indicator input with only a small control current makes switch contacts for small loads possible. Each side of the vehicle is controlled separately.

The construction of the hazard switch could be simplified due to hazard warning input is separate. The flasher will dramatically increase the flash frequency by a typical ratio of 2:1 if lamp fault is detected. The UTC **L2044** can be directly connected to the battery due to extreme low current consumption.

FEATURES

- * Temperature and Supply Voltage Compensated Flashing Frequency
- * Frequency Doubling Indicates Lamp Fault.
- * Two Relay Driver Outputs with High Current-carrying Capacity and Low Saturation Voltage
- * Minimum Lamp Load for Flasher Operation: $\geq 1W$
- * Very Low Sensitivity to EMI
- * Extremely Low Current Consumption $< 10\mu A$ (at Switches Open)
- * Reverse Polarity Protection
- * Three Control Inputs: Left, Right and Hazard Warning

ORDERING INFORMATION

Ordering Number		Package	Packing
Lead Free	Halogen Free		
L2044L-D14-T	L2044G-D14-T	DIP-14	Tube
L2044L-S14-T	L2044G-S14-T	SOP-14	Tube
L2044L-S14-R	L2044G-S14-R	SOP-14	Tape Reel

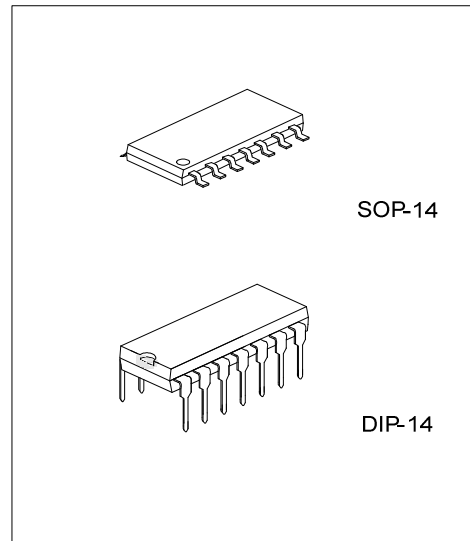

<p>L2044L-D14-T</p> <p>(1) Packing Type (2) Package Type (3) Lead Free</p>	<p>(1) T: Tube, R: Tape Reel (2) D14: DIP-14, S14: SOP-14 (3) L: Lead Free, G: Halogen Free</p>
--	---

■ PIN CONFIGURATION

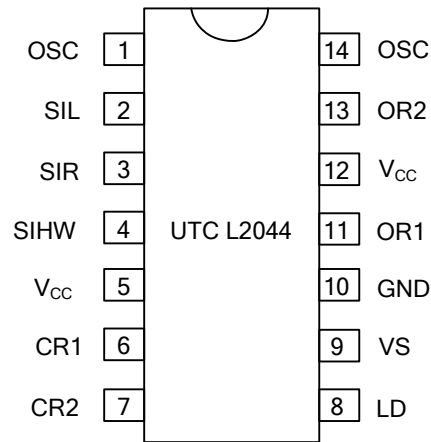

■ PIN DESCRIPTION

PIN No.	PIN NAME	FUNCTION
1	OSC	Oscillator
2	SIL	Start input left
3	SIR	Start input right
4	SIHW	Start input hazard warning
5	V _{cc}	V _{cc}
6	CR1	Control input relay 1
7	CR2	Control input relay 2
8	LD	Lamp failure detection
9	V _{cc}	V _{cc}
10	GND	ground
11	OR1	Output relay 1
12	VS	V _{cc}
13	OR2	Output relay 2
14	OSC	Oscillator

■ BLOCK DIAGRAM

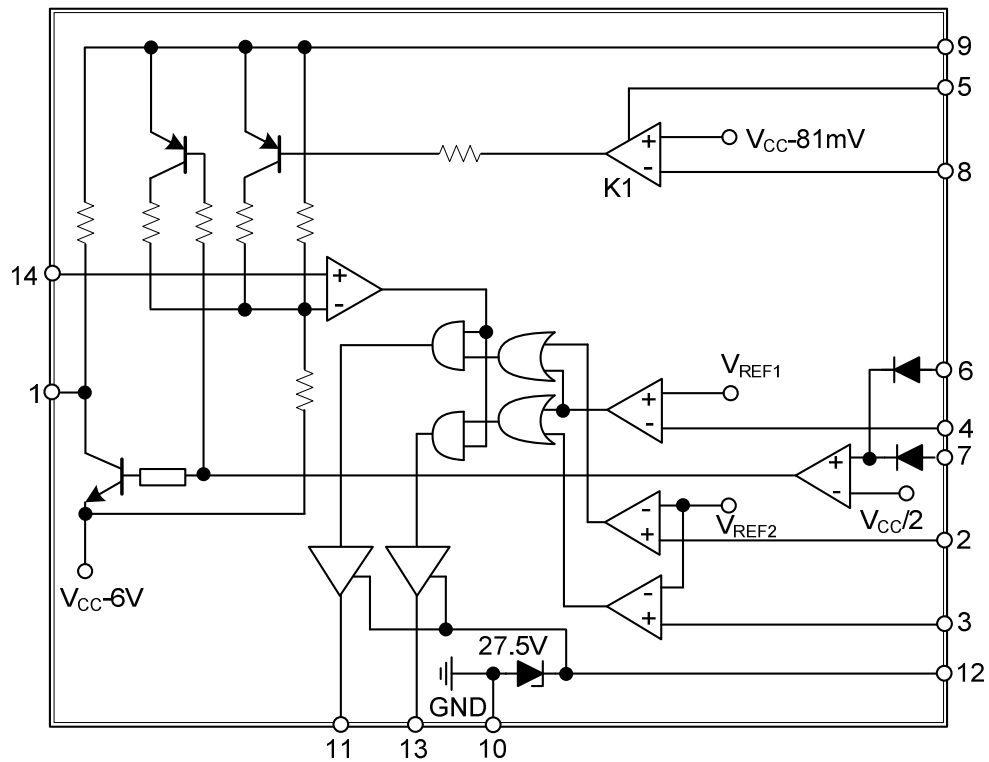

■ ABSOLUTE MAXIMUM RATINGS

PARAMETER	SYMBOL	RATINGS	UNIT
Supply Voltage, 1 min, pins 5, 9 and 12	V_{CC}	24	V
Junction Temperature	T_J	+125	°C
Operating Temperature	T_{OPR}	-20~ +85	°C
Storage Temperature	T_{STG}	-40 ~ +150	°C

Note: Absolute maximum ratings are those values beyond which the device could be permanently damaged.

Absolute maximum ratings are stress ratings only and functional device operation is not implied.

■ THERMAL DATA

PARAMETER	SYMBOL	RATINGS	UNIT
Junction to Ambient	DIP-14	90	°C/W
	SOP-14	120	

■ ELECTRICAL CHARACTERISTICS ($V_{CC} = 12V$, $T_A = 25^\circ C$, unless otherwise specified.)

PARAMETER	SYMBOL	TEST CONDITIONS	MIN	TYP	MAX	UNIT
Supply Voltage Range	V_{CC}	Pins 5, 9, 12	8		18	V
Saturation Voltage	V_{OUT}	$V_{CC}=8V, R_L=82\Omega$			1.0	V
		$V_{CC}=12V, R_L=82\Omega$			1.2	
Clamping Voltage	V_{12}	$T_a = -20^\circ C \sim 85^\circ C$	25.0	27.5	30.0	V
Relay output overvoltage detection (relay disabled)	V_{12}	$T_a = -20^\circ C \sim 85^\circ C$	18	20	22	V
Control signal threshold	V_{CC}	$V_{CC}=9V$		70.6		mV
		$V_{CC}=13.5V$		85.5		
		$V_{CC}=16V$		93.0		
Output current for relay driver	I_{OUT}	Pins 11, 13			300	mA
Relay output reverse current	I_{OUT}	Pins 11, 13			0.1	mA
Supply current, switches open	I_{CC}	Pins 5, 9, 12			10	μA
Relay coil resistance	R_L					Ω
Start delay	t_{ON}	First bright phase			10	ms
Tolerance of control signal threshold		$V_{CC}=9V\sim 16V$, Pin 8, $T_A = -20^\circ C \sim 85^\circ C$	-6		+6	%
Temperature coefficient of control signal Threshold	$T_C V_O$	$V_{CC}=13.5V$, Pin 8		10		$\mu V/K$

■ TOLERANCES ($V_{CC} = 12V$, $T_A = 25^\circ C$, unless otherwise specified.)

PARAMETER	SYMBOL	TEST CONDITIONS	MIN	TYP	MAX	UNIT
Frequency determining resistor	R_1		6.8		510	k Ω
Frequency determining capacitor	C_1				47	μF
Frequency tolerance	Δf_1	Normal flashing, basic frequency f_1 excluding the tolerance of R_1 and C_1	-5		+5	%
Bright period	Δf_1	Basic frequency f_1	47		53	%
	Δf_2	Control frequency f_2	37		45	
Frequency increase	f_2	Lamp failure	$2.15 \times f_1$		$2.3 \times f_1$	Hz
Lamp load	P_L		1			W

TYPICAL APPLICATION CIRCUIT

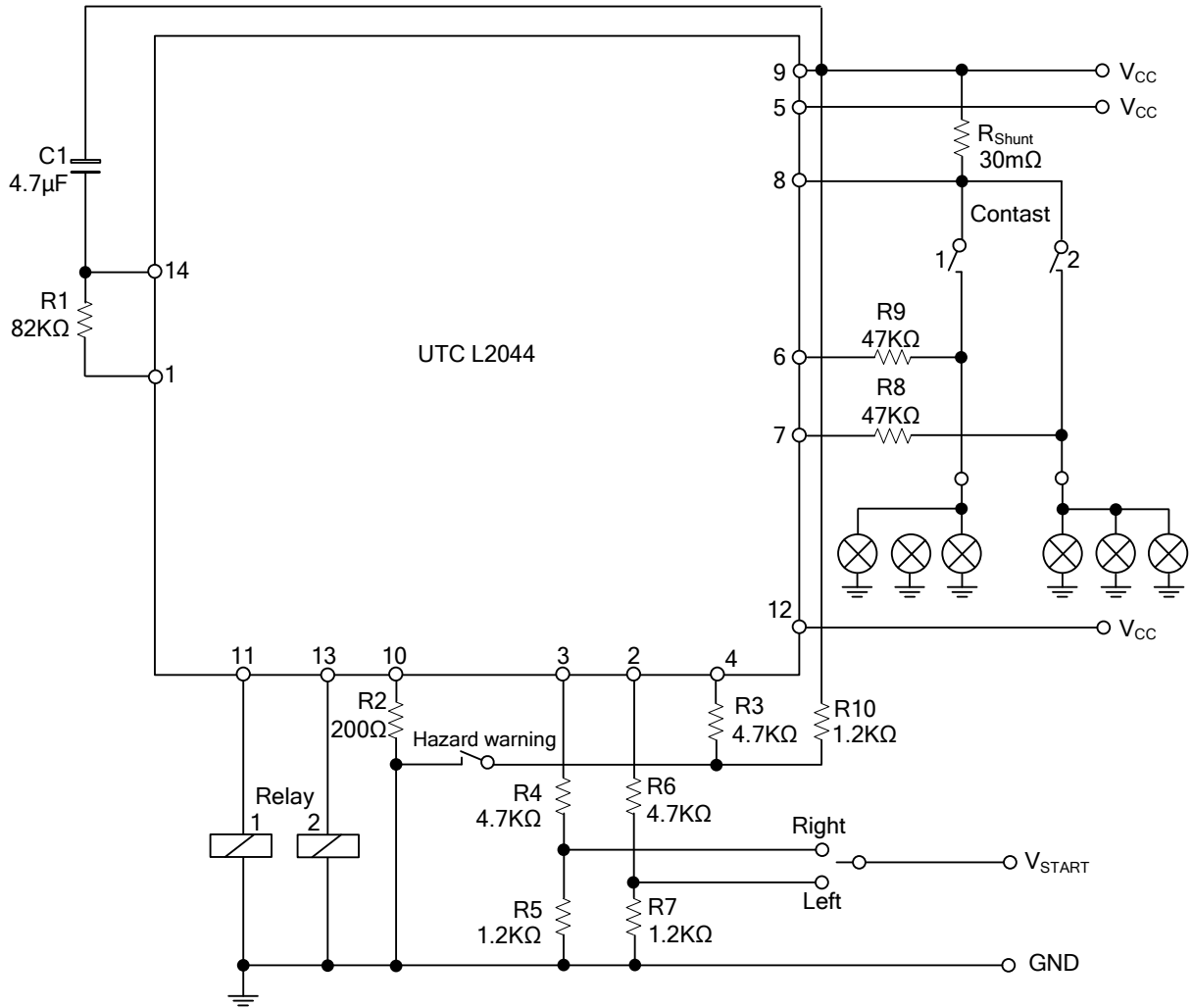

UTC assumes no responsibility for equipment failures that result from using products at values that exceed, even momentarily, rated values (such as maximum ratings, operating condition ranges, or other parameters) listed in products specifications of any and all UTC products described or contained herein. UTC products are not designed for use in life support appliances, devices or systems where malfunction of these products can be reasonably expected to result in personal injury. Reproduction in whole or in part is prohibited without the prior written consent of the copyright owner. The information presented in this document does not form part of any quotation or contract, is believed to be accurate and reliable and may be changed without notice.