

DUAL TONE MELODY XMAS LIGHT CONTROL

FEATURES

- \* 5 SCR outputs.
- \* 2 Mode sequence trigger key
- \* Mode 0: 7 function Vol pin control volume.  
Mode 1: 8 function Auto Volume control.
- \* OPT: "Floation" Mode 0  
"VSS" Mode 1.

APPLICATION

- \* Xmas light control etc..

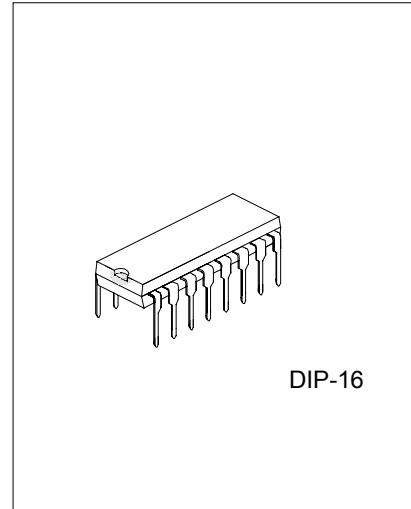

Pin Assignment

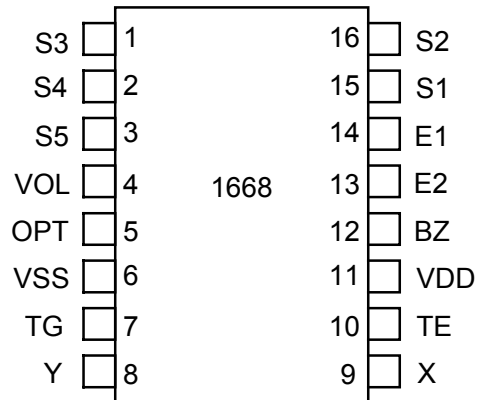

PAD COORDINATES

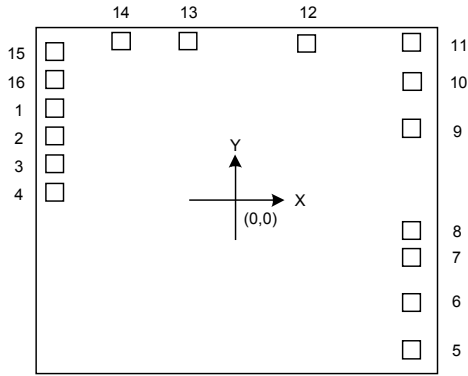

CHIP SIZE: 2.00 × 1.72mm<sup>2</sup>  
SUBSTRATE: VDD

NO	NAME	X	Y
1	S3	-911.3	436.3
2	S4	-911.3	296.4
3	S5	-911.3	156.4
4	VOL	-911.3	15
5	OPT	896.4	-772.8
6	VSS	896.4	-534.3
7	TG	896.4	-312.2
8	Y	896.4	-172.5
9	X	896.4	338.2
10	TE	896.4	571.8
11	VDD	896.4	765.6
12	BZ	369.6	757.1
13	E2	-218.2	772.7
14	E1	-554.5	772.7
15	S1	-911.3	716.4
16	S2	-911.3	576.4

UNIT:um

ELECTRICAL CHARACTERISTICS (VDD=4.3V,unless otherwise specified)

PARAMETER	SYMBOL	TEST CONDITIONS	MIN.	TYP.	MAX.	UNIT
Operating Voltage	VDD			4.3	5	V
Operating Current	Iop	No load			2	mA
BZ Driving Current	Ioh	Vds=1V		0.2		mA
Oscillator Frequency	Fosc	External ±30%, Rosc=270KΩ		100		KHz
Operating Temperature	Topr		0	25	60	°C

MODE FORMAT

MODE	MODE 0		MODE 1	
	LIGHT		LIGHT	VOLUME
M1	Inphase		Inphase	Max.
M2	2 Mode Sequential		2 Mode Sequential	Middle
M3	1 Lamp Flash		1 Lamp Flash	Min.
M4	2 Lamp Chasing		Rotary	Max.
M5	M1~M4 Rotary		Inphase + 2 Lamp Chasing	Middle
M6	M1~M4 Rotary		2 Mode Sequential + 1 Lamp Flash	Min.
M7	Steady on		Rotary	Mute
M8			Steady on	

SONG LIST

No.	SONG NAME	No.	SONG NAME
1	Angels we have heard on high	14	Santa Claus coming to down
2	Silent night	15	O Christmas tree
3	Away in a manger	16	Rudolph, the red-nosed reindeer
4	We three king of orient are	17	What child is this
5	Jingle balls	18	I saw three ships
6	We wish you a merry Christmas	19	O litter town of Bethlehem
7	The twelve days of Christmas	20	God rest you merry, gentlemen hark
8	Up on the housetop	21	Deck the halls
9	Jolly old saint nickel	22	The hearld angels sing
10	Good king wencelas	23	The snow lay on the ground
11	O come ,all ye faithful	24	Bring a torch
12	Joy to the world	25	The first noel
13	It came upon the midnight clear		

APPLICATION CIRCUIT

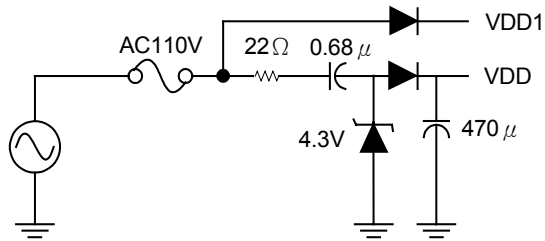

APPLICATION DIAGRAM

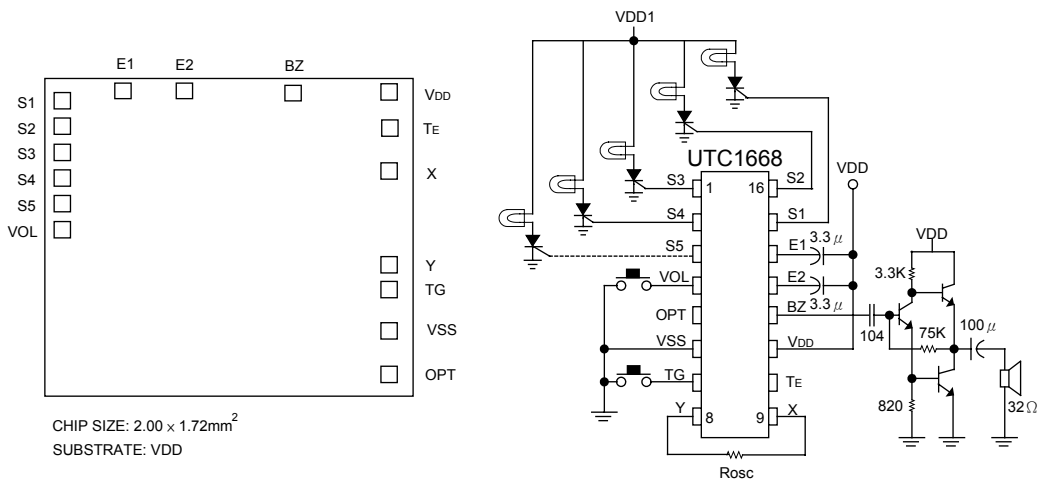

UTC assumes no responsibility for equipment failures that result from using products at values that exceed, even momentarily, rated values (such as maximum ratings, operating condition ranges, or other parameters) listed in products specifications of any and all UTC products described or contained herein. UTC products are not designed for use in life support appliances, devices or systems where malfunction of these products can be reasonably expected to result in personal injury. Reproduction in whole or in part is prohibited without the prior written consent of the copyright owner. The information presented in this document does not form part of any quotation or contract, is believed to be accurate and reliable and may be changed without notice.