

FEATURES

- Simple and Easy Charge Management for Vibration Energy Harvesting
- Integrates directly with all Vulture™ Energy Harvesters
- Parallel or Series Piezoelectric Connection – Improved Efficiency
- User Selectable DC Output – (1.8V, 2.5V, 3.3V, 3.6V)

APPLICATIONS

- Industrial Health Monitoring Network Sensors
- Condition Based Maintenance Sensors
- Wireless HVAC Sensors
- Mobile Asset Tracking
- Tire Pressure Sensors
- Oil and Gas Sensors
- All Air, Land, and Sea Vehicle Sensors
- Battery and Hard Wired Power Replacement

DESCRIPTION

The EHE004 is an energy harvesting power conditioning circuit, which converts the AC output from a piezoelectric energy harvester to a regulated DC output.

The EHE004 consists of a full-wave rectifier with integrated charge management and DC-DC conversion, and connects directly to any Vulture™ piezoelectric energy harvesting product. The DC output can be configured to the following voltage settings: 1.8V, 2.5V, 3.3V, and 3.6V. The board includes 200 μF of storage capacitance onboard - more capacitance can be added if required.

The EHE004 utilizes the Linear Technology LTC3588-1 piezoelectric charge management IC - designed to maximize total piezoelectric energy harvester output and mechanical-to-electrical conversion efficiency with medium to heavy loads.

Each Vulture™ energy harvesting product has two piezoelectric wafers. The EHE004 provides the user with ability to connect these wafers either in series or parallel. The series setting provides power output at lower g levels for small vibration amplitude applications. The parallel setting provides higher average power output levels at higher vibration amplitude levels.

For more information please contact Mide Tech. Corp by emailing: vulture@mide.com

TYPICAL APPLICATION

Figure 1: Representative energy harvesting system using a Vulture™ piezoelectric energy harvester and the EHE004 charge management electronics.

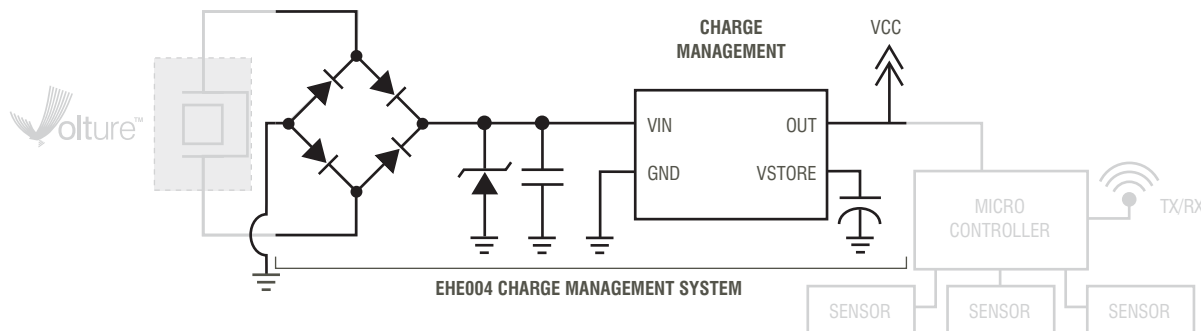

ELECTRICAL CHARACTERISTICS

The LTC3588-1 Piezoelectric Energy Harvesting Power Supply from Linear Technology is the primary component on the EHE004. From Linear Technology's datasheet:

“The LTC3588-1 integrates a low-loss full-wave bridge rectifier with a high efficiency buck converter to form a complete energy harvesting solution optimized for high output impedance energy sources such as piezoelectric transducers. An ultralow quiescent current undervoltage lockout (UVLO) mode with a wide hysteresis window allows charge to accumulate on an input capacitor until the buck converter can efficiently transfer a portion of the stored charge to the output. In regulation, the LTC3588-1 enters a sleep state in which both input and output quiescent currents are minimal. The buck converter turns on and off as needed to maintain regulation.

Four output voltages, 1.8V, 2.5V, 3.3V and 3.6V, are pin selectable with up to 100mA of continuous output current; however, the output capacitor may be sized to service a higher output current burst. An input protective shunt set at 20V enables greater energy storage for a given amount of input capacitance.”

For more information on the LTC3588-1 please visit:
<http://cds.linear.com/docs/Datasheet/35881fa.pdf>

PRINCIPLE OF OPERATION

Referring to Figure 2b, The LTC3588-1 power supply IC integrates an extremely low quiescent current voltage comparator with a highly efficient buck regulator. The buck regulator is activated when the rectified input voltage, VCAP, rises above the pre-set undervoltage lockout (UVLO) rising voltage threshold for the chosen output voltage setting (Page 5 table 'Specification'). The regulator remains active until the input voltage has been depleted to the UVLO falling threshold, at which point the buck operation is disabled. Thus, for as long as the load demand exceeds the input power (as in typical sensor or battery charger applications), the input voltage will hover between the UVLO rising and falling thresholds. In cases where the input power exceeds the load demand, the VCAP voltage will rise beyond the UVLO rising threshold, storing the excess power on the input capacitor. If the voltage at VCAP exceeds approximately 20VDC, an internal voltage clamp (5mA continuous rating) prevents damage to the device.

CONFIGURATION

The EHE004 has two means of signal rectification (Normal and Superseries) and two ways to connect the two piezoelectric wafers in a Vulture™ product (Series and Parallel). There are also four options for the regulated DC output (1.8V, 2.5V, 3.3V, and 3.6V). In total there are sixteen possible configuration settings. The vibration environment and voltage requirements dictated by the application will determine the best configuration settings for the EHE004.

Maximum Power Point:

The efficiency of power transfer from the piezo to the load, and thus normalized power (mW/G), will be at maximum when the loaded piezo voltage (for moderate to heavy loads, equal to the average UVLO voltage) is approximately 1/2 its open-circuit voltage. However, the output will continue to increase with increasing vibration amplitude. For light loads where VCAP is not depleted to the UVLO voltage during buck operation, transfer efficiency is inconsequential as more power is available than the load can use.

Normal vs. “Superseries”:

The difference between ‘Normal’ and ‘Superseries’, is the bridge rectifier connection. In the normal mode of operation, the bridge rectifier is operated in fullbridge mode and its output voltage is half the peak-to-peak input voltage minus two diode drops. In the “superseries” configuration, the rectifier operates in a half-bridge mode with only one diode drop. The normal mode is recommended for maximum power output at moderate input voltages, however the halfbridge mode will allow operation from slightly lower minimum input voltages.

Parallel vs. Series operation:

All of MIDE’s Vulture products contain two piezo elements stacked in a bimorph configuration and pinned out independently, allowing the user to choose between parallel and series connection. On the EHE004 board, switch SW1 selects between parallel (doubled current, lower input voltage) and series (doubled input voltage, lower current) connection. Generally low level vibrations are best suited to the series configuration and high level vibrations are best suited to the parallel configuration. However, the optimal setting will depend on a number of factors including which Vulture product is being used and the parameters of the vibration environment.

The table below shows the general configuration settings for different application types. However, each application is unique and the optimal settings will depend on both the application and Vulture™ or other piezoelectric element used for the energy conversion.

Application (Vibration Level)	General EHE004 Configuration Settings	
	SW1	SW3
Very Low Amplitude	Series	Superseries
Low to Moderate Amplitude	Series	or Superseries
Moderate Amplitude	Parallel	Normal
High Amplitude	Parallel	Normal

Table 1: General configuration guide listing for various applications. Every application is unique and may not fit these general settings.

CONFIGURATION

How do I configure the EHE004?

Configuring the EHE004 is done by using the combination of switches which appear on the top side of the board. The switch at the top right, designated SW3, controls the bridge rectifier connection. Place in the “NORM” position (downward) for normal operation, and the “SS” position for half-wave (“superseries”) operation. The switch in the lower right hand side,

SW1, switches between parallel (downward, “Par.” position) and series (upward, “Ser.” position) piezo connection. The switch located in the top left hand corner of the board, designated SW2, sets the output voltage as marked below. In the legend below, the left and right digit refer to the left and right toggle switch, respectively, and the “1” or ON position is toward the dot marked on the switch.

Switch #2 (SW2)

– DC Output Setting

SWITCH UP FIRST DECIMAL BECOMES = 00
 SWITCH DOWN FIRST DECIMAL BECOMES = 10
 SWITCH UP SECOND DECIMAL BECOMES = 00
 SWITCH DOWN SECOND DECIMAL BECOMES = 01

OUTPUT VOLTAGE

SWITCH #2 LEFT & RIGHT
 00 = 1.8V = UP UP
 10 = 3.3V = DOWN UP
 01 = 2.5V = UP DOWN
 11 = 3.6V = DOWN DOWN

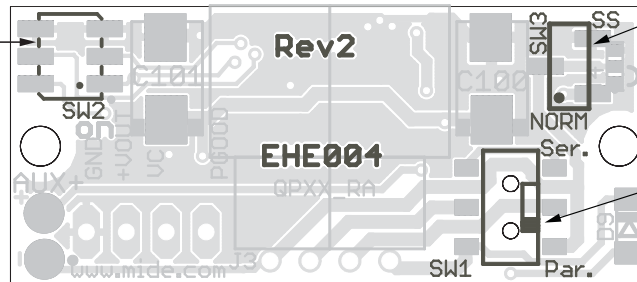

Switch #3 (SW3)

– Rectification Method

SUPERSERIES – SWITCH UP
 NORMAL – SWITCH DOWN

Switch #1 (SW1)

– Piezo Connection

SERIES – SWITCH UP
 PARALLEL – SWITCH DOWN

CONNECTION INFORMATION

The terminal block at the bottom-left of the board (solder or screw terminals) provides the regulated output and other signals from the EHE004. The connections from left to right are:

GND – Electrical ground

VOUT – Regulated output voltage

VCAP – Test point for measuring the voltage across the input capacitor(s). Additional capacitance can be added between this terminal & GND as needed.

PGOOD – Active-high Power Good signal. This signal will be high (true) when the output is in regulation and will go low (false) when the output voltage drops below 92% of its regulated value. This will typically occur once the input voltage falls below the UVLO threshold or if the maximum output current is exceeded.

In addition, a low-voltage auxiliary power source, such as a solar cell, can be added by soldering to the AUX+ and AUX- pads at the bottom-left corner of the board, provided the source complies with the absolute maximum ratings set forth above ($V_{AC} \leq 18V$, $R_{SOURCE} > 400 \Omega$, SW3=SUPERSERIES). A blocking diode (400mV typical voltage drop) in series with the AUX input prevents reverse leakage across the device.

SPECIFICATIONS

The following provides a brief summary of the most important specifications of the EHE004. For complete specifications and performance plots for the LTC3588-1 charge management IC, please refer to the LTC3588-1 data sheet.

For Vulture™ specifications, such as typical relationships between frequency, tip mass and output voltage for each product, please refer to the [Vulture™ data sheet](#).

Specification		Value (typical @ 25°C)
Input capacitance		200uF (stock product – custom values available upon request)
Output capacitance		10uF
Maximum Input Voltage		18V (low impedance sources) ¹
Maximum Peak Protective Shunt Current		25mA (1ms duration)
Maximum Continuous Protective Shunt Current		5mA
Quiescent Current	UVLO	450nA
	Buck Enabled, Sleeping (Vin = 4.5V)	950nA
	Buck Enabled, Sleeping (Vin = 18V)	1.7uA
	Buck Enabled, Active ²	150uA
Maximum Output Current		100mA

NOTE 1: An internal clamp circuit limits the input voltage to 20V; the maximum input voltage stated may be safely exceeded provided the maximum input current condition is satisfied.

NOTE 2: Does not include active switching or inductor currents ($I_{sw}=0$). Dynamic supply current is higher due to gate charge being delivered at the switching frequency.

OPERATION

Vout setting (V)	UVLO rising (V)	UVLO falling (V)	Vmpp (V) ¹	Vmin (V) ²	Vripple @ Vin=UVLO (mV) ³	Vripple @ Vin=20 (mV) ³
1.8	4.04	2.87	7.4	3.1	120	160
2.5	4.04	2.87	7.5	3.1	120	160
3.3	5.05	3.67	9.3	3.6	140	280
3.6	5.05	4.02	9.6	3.6	160	300

NOTE 1: Approximate maximum power point (open-circuit piezo voltage) at which power transfer to the load is maximized.

NOTE 2: Minimum start-up voltage in halfbridge (“superseries”) configuration.

NOTE 3: Ripple values measured at no load and the 10uF onboard output capacitance.

PERFORMANCE PLOTS

The EHE004 performance was measured while connected to a Vulture™ V25W piezoelectric energy harvester. The system was properly clamped and tuned using the procedures detailed in the Vulture™ datasheet. The assembly was attached to a shake table to generate vibrations to test the system. The shake table was driven by a function generator and the amplitude was measured with an accelerometer. To determine average power, the output duty cycle at the known output voltage over a fixed 1.00K-ohm load was measured.

Performance measurements were taken at 0.25g, 0.50g, 0.75g, and 1g amplitudes. The lowest amplitude at which the EHE004 input exceeded the UVLO threshold, producing a usable output, was also recorded. The figure below shows the results for these tests. For the same amplitude conditions, other Vulture™ products would exhibit similar performance characteristics though with different power output levels. Typical average power output levels for

Vulture™ energy harvesting products can be found on the Vulture™ datasheet.

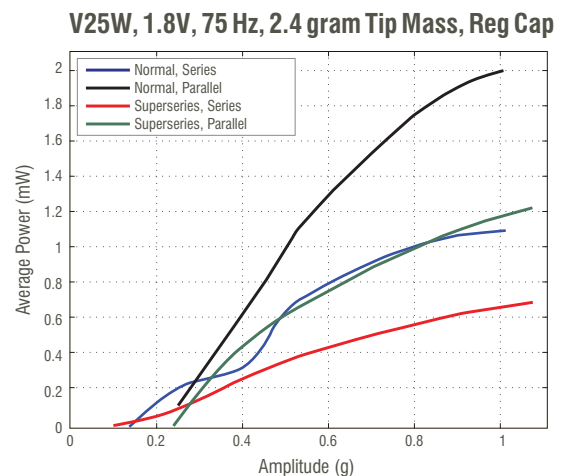

This representative figure shows how the different settings on the EHE004 can be used most efficiently given the vibration profile that this specific energy harvester with this tip mass was subjected to. For lowest amplitude vibrations (in this instance below 0.175 gee)

PERFORMANCE PLOTS

the only setting that was able to provide any output was the Superseries, Parallel setting. From approximately 0.175 gee to 0.25 gee the Normal, Series setting was best. For all amplitudes above 0.25 gee the Normal, Parallel was the most efficient. It should be noted that these curves will vary substantially depending on the product that is used as well as the tip mass that is used

to tune the product. In conclusion what this representative curve shows is that the piezo's output energy and voltage for certain settings will allow the system to operate closer to the half open circuit voltage causing more efficient operation. For low level vibration the series setting is needed to get the piezo voltage output to reach the minimum voltage to operate the EHE004.

BOARD SCHEMATIC AND DIMENSIONS

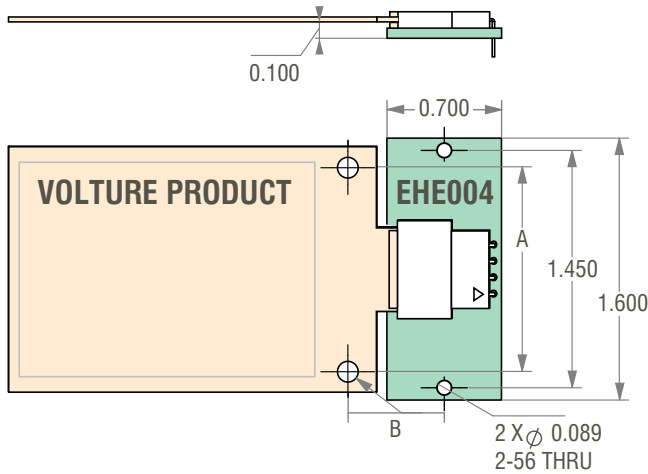

Vulture™ Product	A	B without J3 Connector	B with J3 Connector
V20W / V25W	1.250	0.588	0.986
V21B / V21BL	0.600	0.633	1.031
V22B / V22BL	N/A	N/A	N/A
V20W / V25W	1.250	0.588	0.986
V21B / V21BL	0.600	0.633	1.031
V22B / V22BL	N/A	N/A	N/A

Figure 2: EHE004 Board dimensions when used with one of Mide's Vulture energy harvesters. Maximum component height on the board is 0.10". All dimensions are in inches.

Vulture V2xx pin 1-4 is as follows:
Piezo wafers on pin 1&2, 3&4

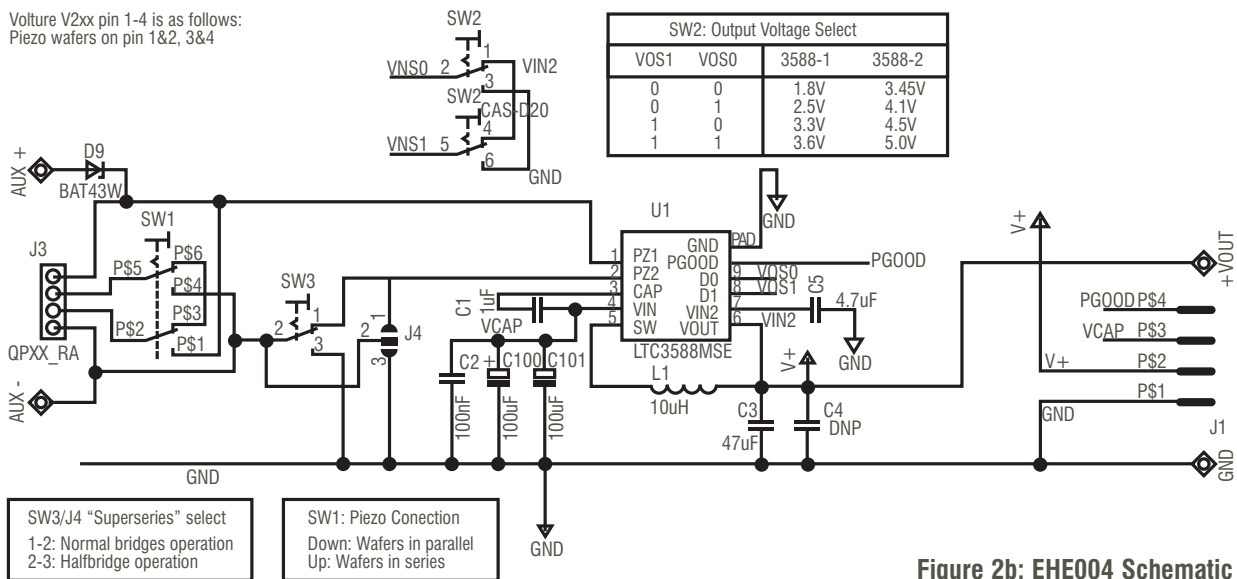

Figure 2b: EHE004 Schematic

BOARD SCHEMATIC AND DIMENSIONS

Table 1: EHE004 Bill of Materials

Qty	Parts (Ref Des.)	Package	Value	Manufacturer Part Number
1	C1	0603	1uF	Yageo, CC0603ZRY5V7BB105
1	C5	0603	4.7uF	Murata, GRM188R60J475ME19D
1	L1	1210	10uH	Taiyo Yuden, CBC3225T100MR
1	C3	1206	47uF	Kemet, C1206C476M9PACTU
1	C2	0603	100nF	TDK, C1608Y5V1E104Z
2	C100, C101	Case D (7343 Metric)	100uF	Kemet, T491X107K025ZT
1	J1	0.100" Screw Terminals		Phoenix Contact, 1725672
1	D9	SOD80C	BAT43W	Micro Commercial Co., BAT43W-TP
1	SW3	CAS-120		Copal Electronics, CAS-120TA
1	SW2	CAS-D20		Copal Electronics, CAS-D20TB
1	U1	10-MSOP		Linear Technology, LTC3588EMSE-1#PBF
1	J3	0.100" x 4		Sullins, PPTC041LGBN-R
1	SW1	EG1390		E-Switch, EG1390A

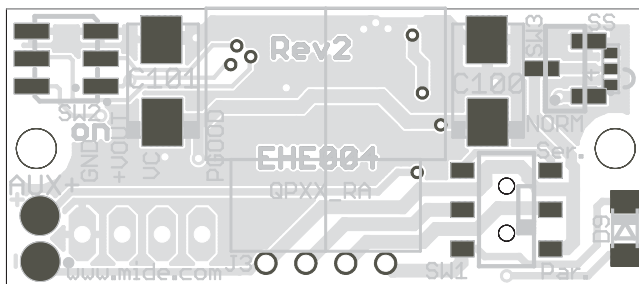

Figure 3: PCB top side

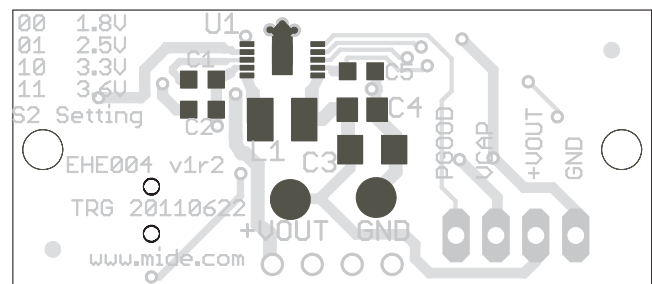

Figure 4: PCB bottom side