



Underside View
(this side faces the passenger)



Top View
(this side faces the sky)



AA.107.301111

Specification

Part No.	AA.107.301111
Product Name	Stingray Low Profile Adhesive Mount GPS-GLONASS Antenna
Feature	1575.42/1602MHz 55mm*51.7mm*10.8mm 3.3V 3M RG174 SMA(M) IP65 Rated Custom cables and connectors available RoHS Compliant

1. Introduction

The Stingray low profile Adhesive Mount (only 10.8mm in height) GNSS antenna is designed for applications which require high positioning accuracy by combining signals from GPS and GLONASS systems. A high gain wide-band patch antenna on an integral ground delivers reliable

performance, ideal for those applications that require durability, small size and covert installation, and reliable reception and transmission crossing through different mobile networks. Its high quality low profile covert housing can be attached onto the glass or even out of sight under the dashboard.

The standard version has 3 metres RG174 cable and SMA(M) connector. The cables and connectors are completely customizable according to customer request.

2. Antenna Block Diagram

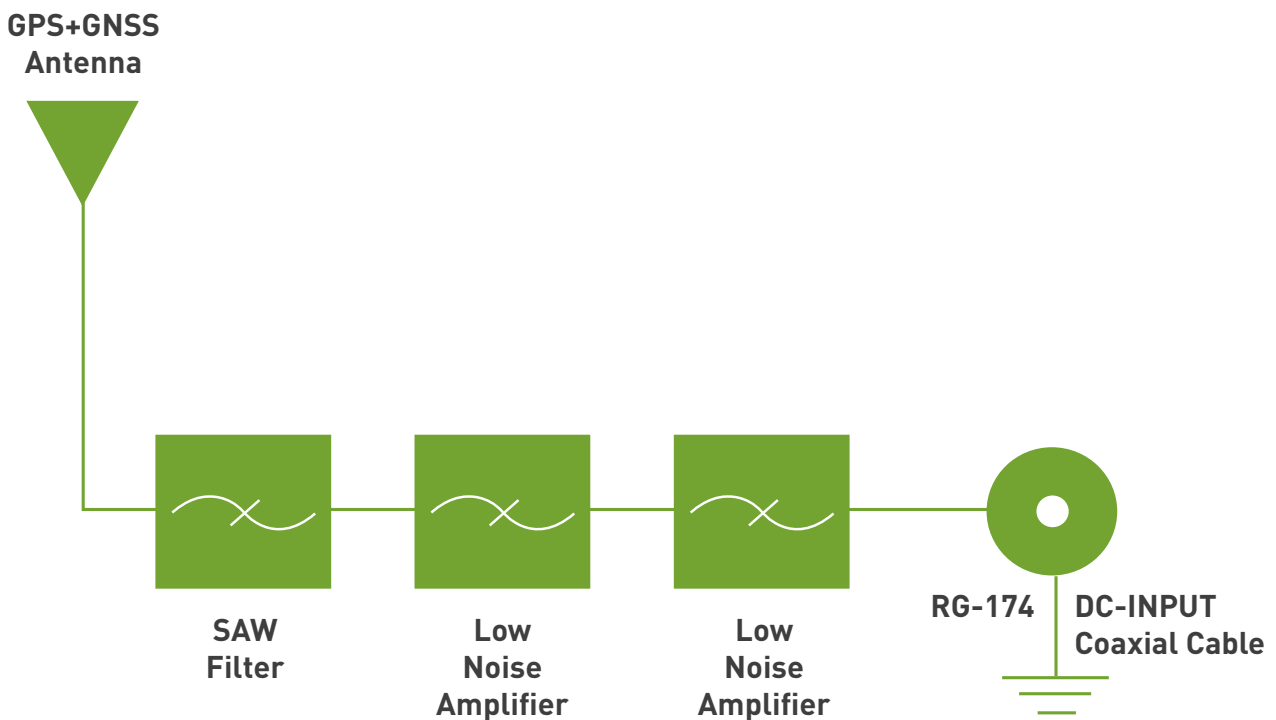

3. Specification

3.1 Performance Specifications

Electrical

Centre Frequency	GPS: 1574.42MHz±3MHz GLONASS: 1602MHz±0.5MHz
LNA Gain at 3.3V	28dB Typ.
VSWR	2.0:1
Impedance	50Ω
Return Loss	10dB Min.
Impedance	50Ω
DC power Input	3.3V
Noise Figure	2.2dB Typ.
Power Consumption	10mA Typ.

Mechanical

Antenna Dimensions	55 x 51.7 x 10.8mm
Housing Material	UV Resistant ABS
Cable	3M RG174 (fully customizable)
Connector	SMA(M) (fully customizable)

Environmental

Operation Temperature	-40°C to 85°C
Storage Temperature	-40°C to 85°C
Relative Humidity	40% to 95%

4. GPS/GLONASS Antenna - Setup

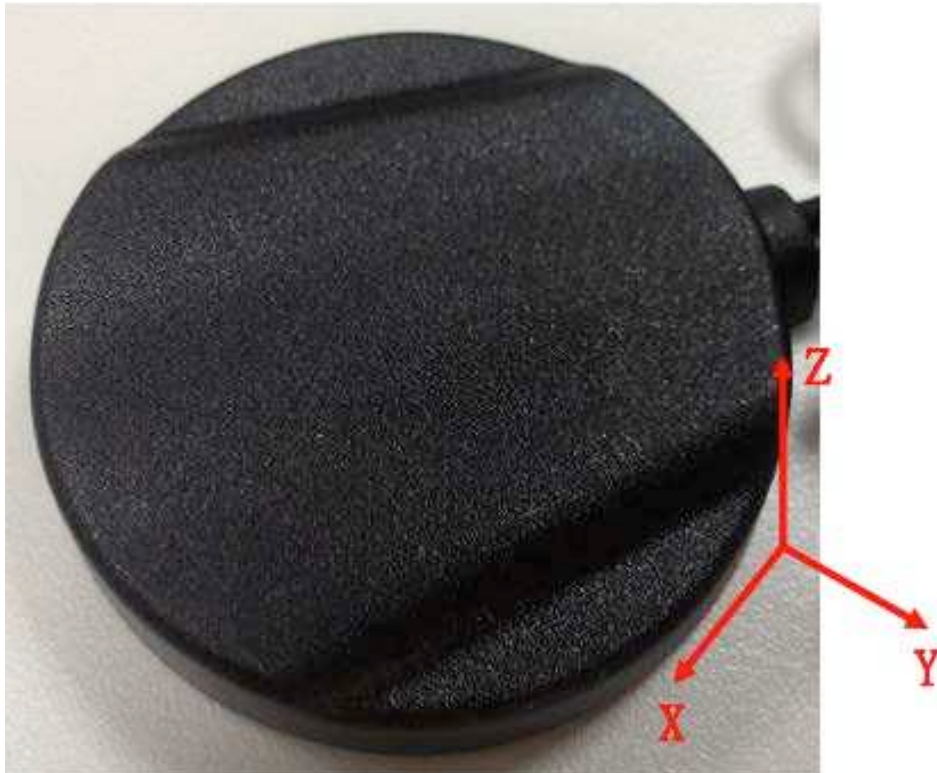

4.1 GPS/GLONASS Antenna

4.1.1 Smith Chart - Impedance

Tr1 S11 Smith (R+j)(I) Scale 1.000U [F2]

1	1.5754200 GHz	78.860 Ω	13.968 Ω
> 2	1.6020000 GHz	31.850 Ω	-6.0578 Ω

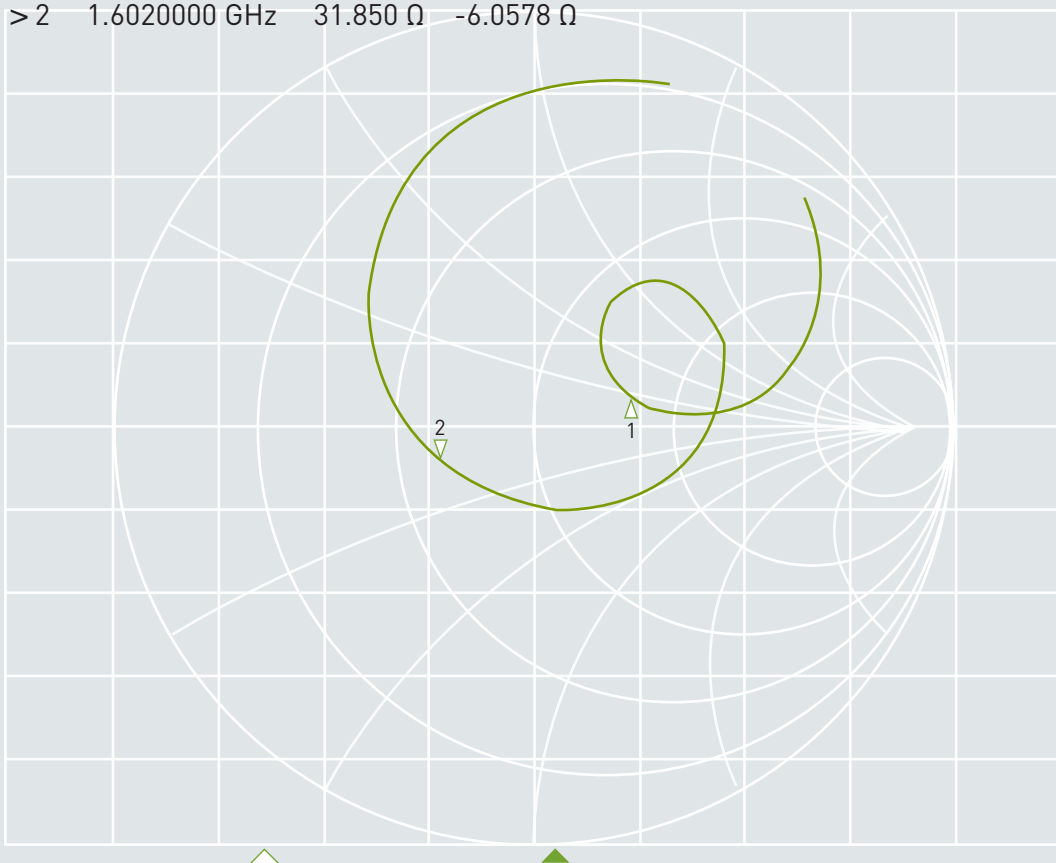

4.1.2 VSWR

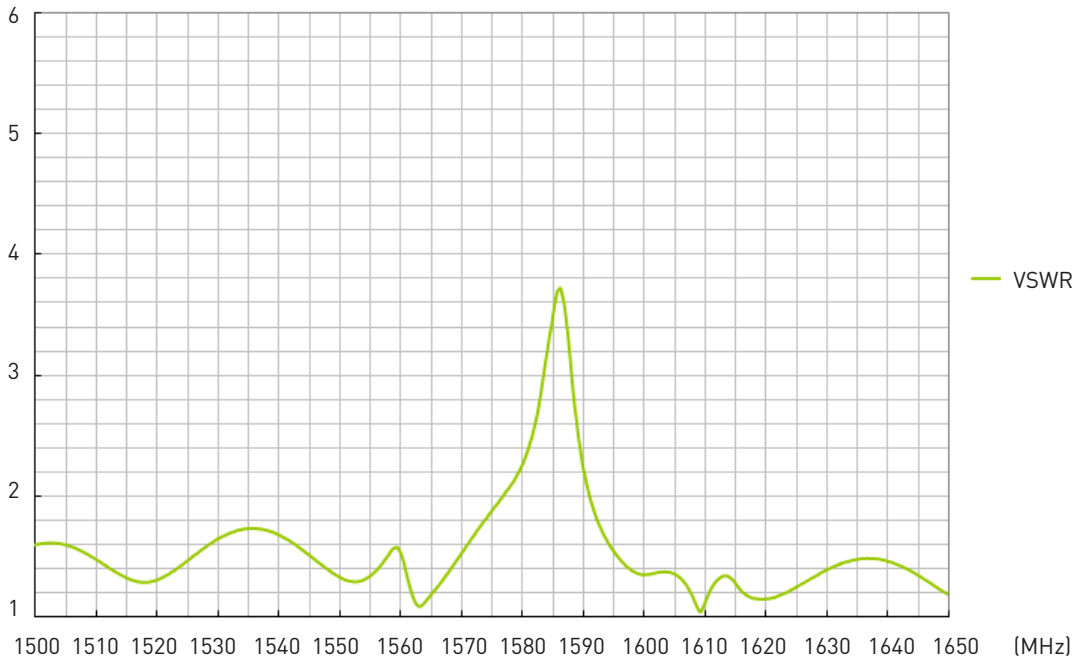

4.1.3 Return Loss

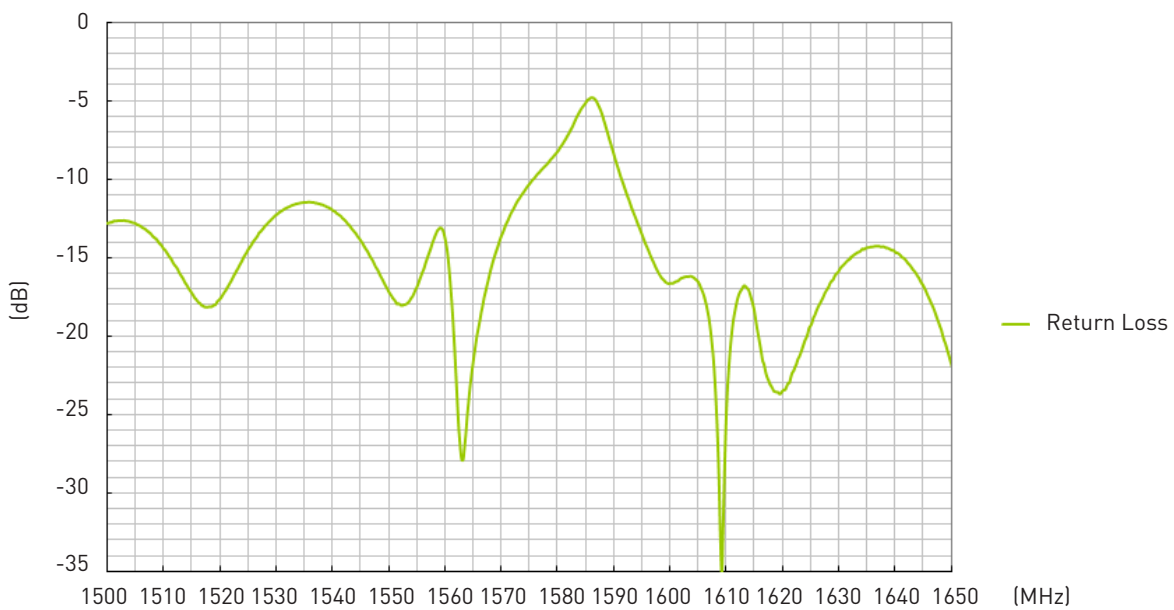

4.2 GPS/GLONASS Antenna Radiation Patterns

1575MHz

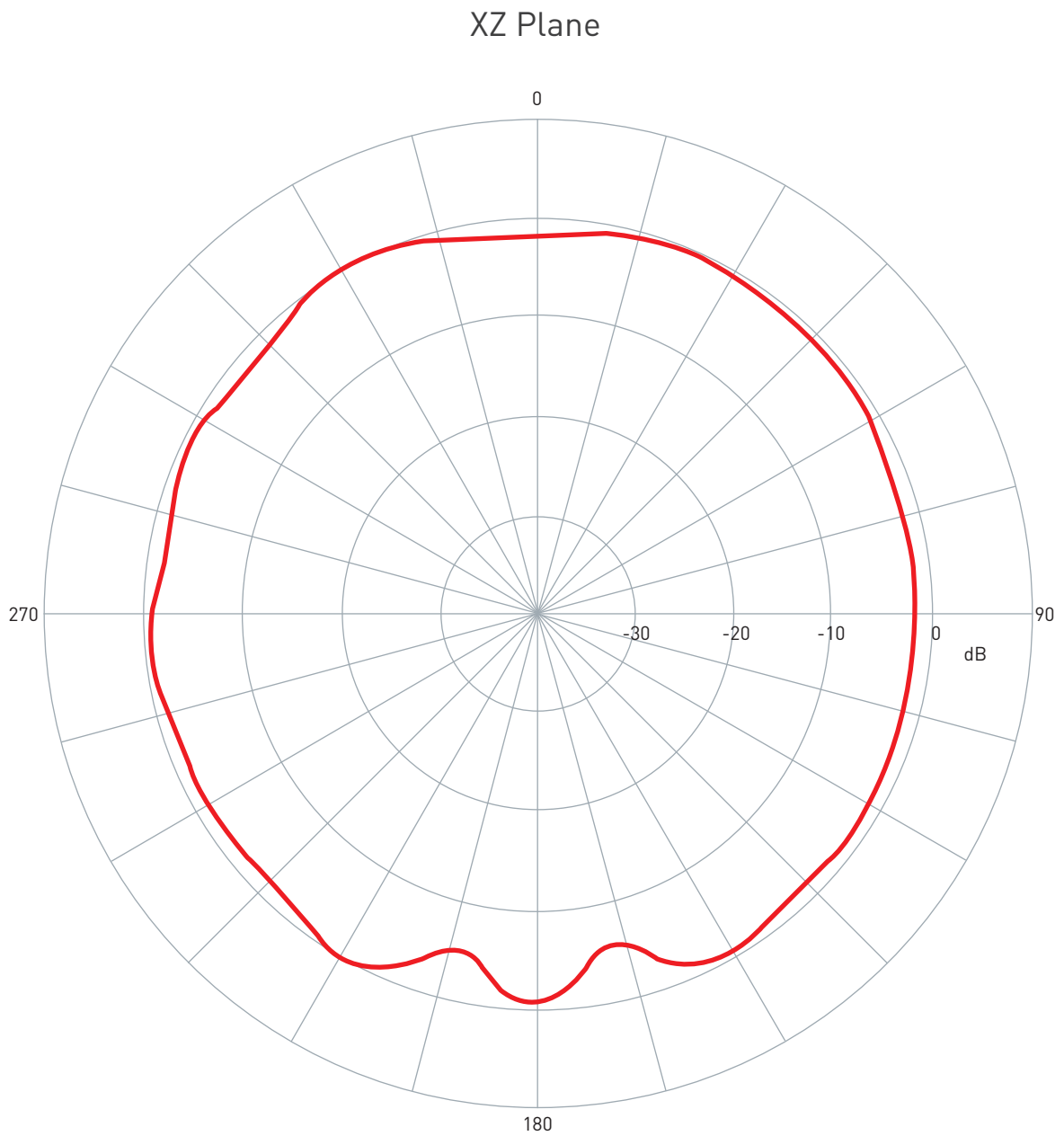

4.2 GPS/GLONASS Antenna Radiation Patterns

1575MHz

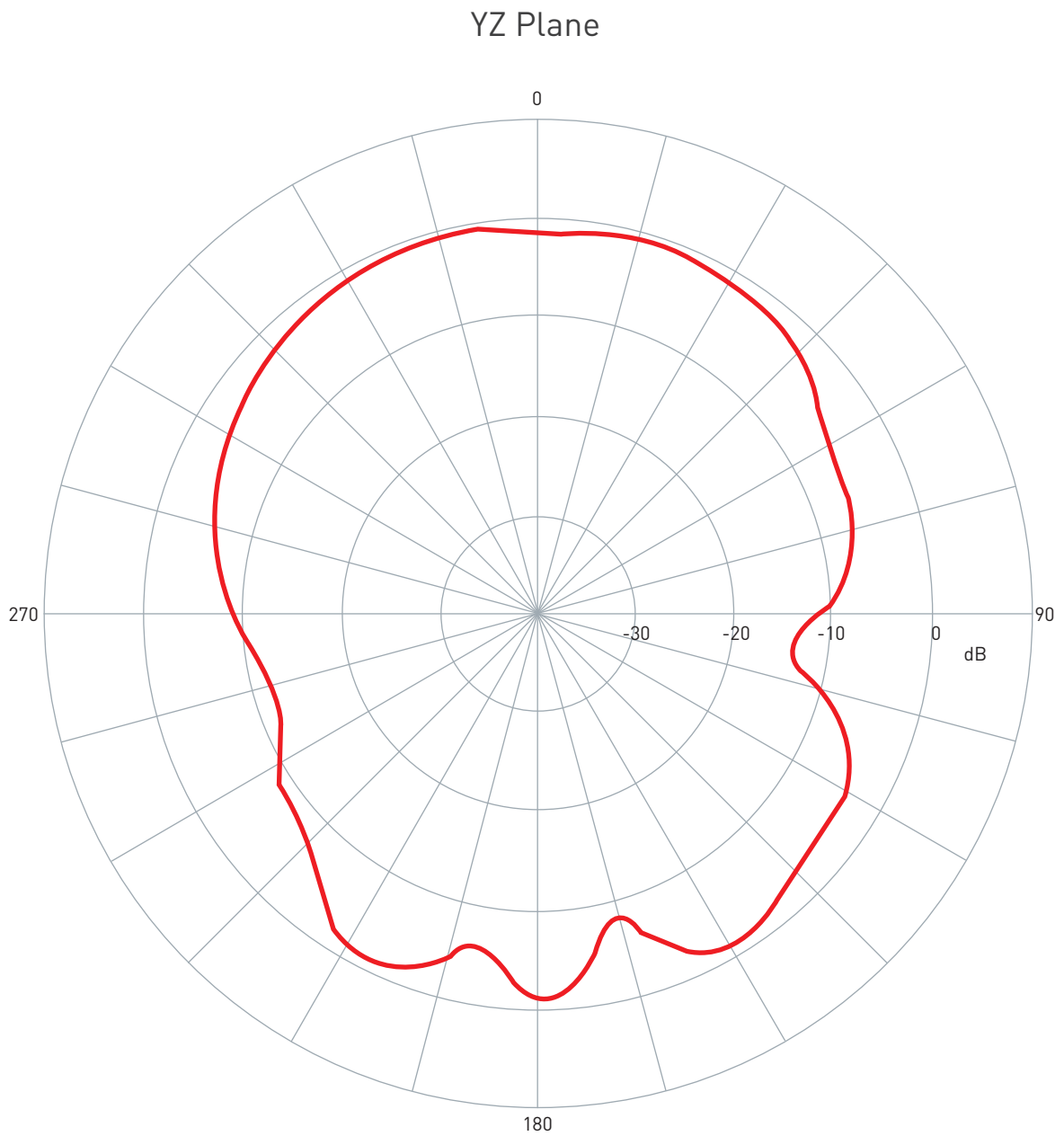

4.2 GPS/GLONASS Antenna Radiation Patterns

1602MHz

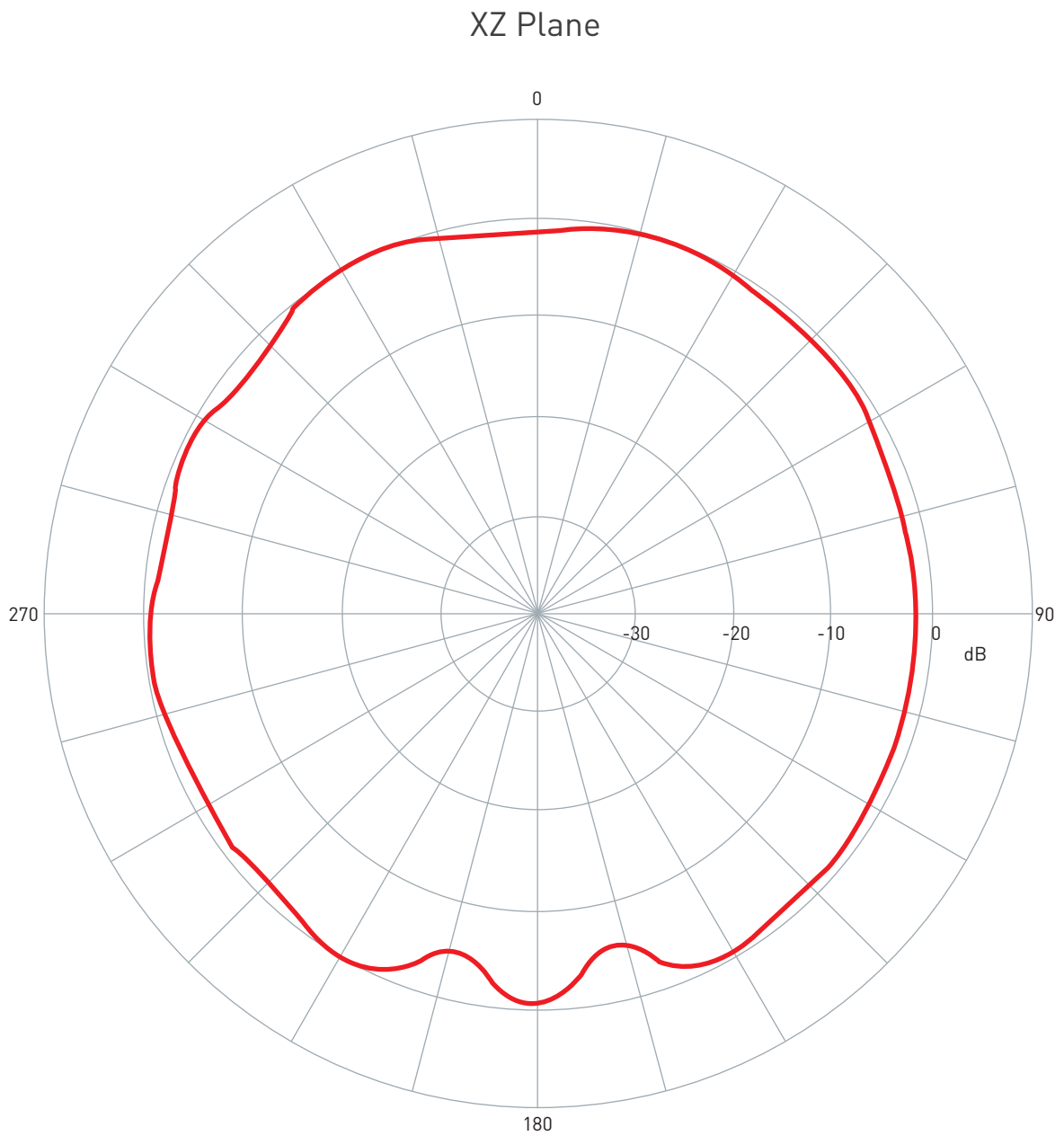

4.2 GPS/GLONASS Antenna Radiation Patterns

1602MHz

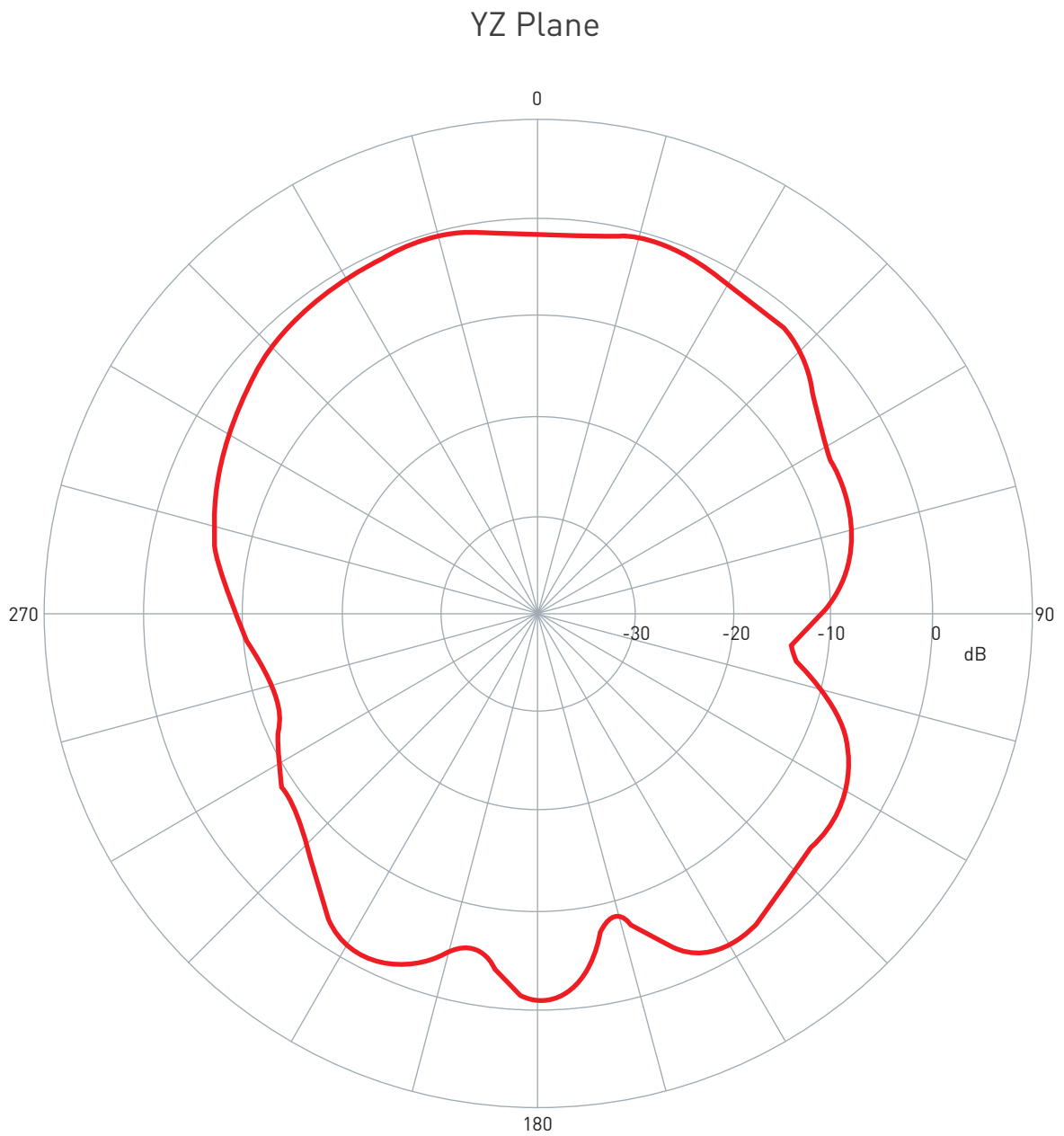

4.3 GPS/GLONASS Antenna Gain Chart

Frequency(MHz)	Peak Gain(dBi)	Efficiency(%)
1575	1.36	50.13
1602	0.09	52.64

4.4 GPS/GLONASS LNA Gain

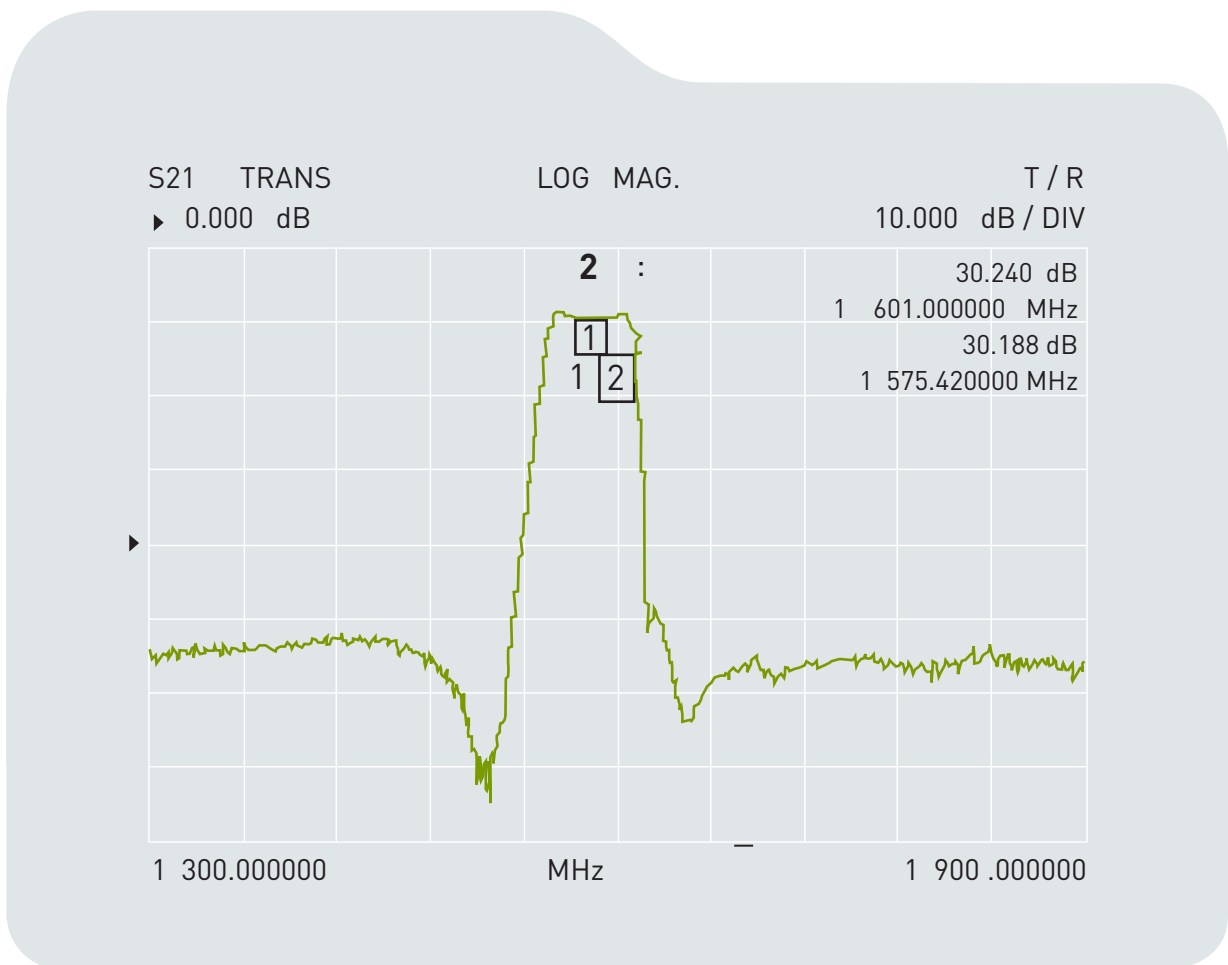

4.5 GPS/GLONASS LNA Output Return Loss

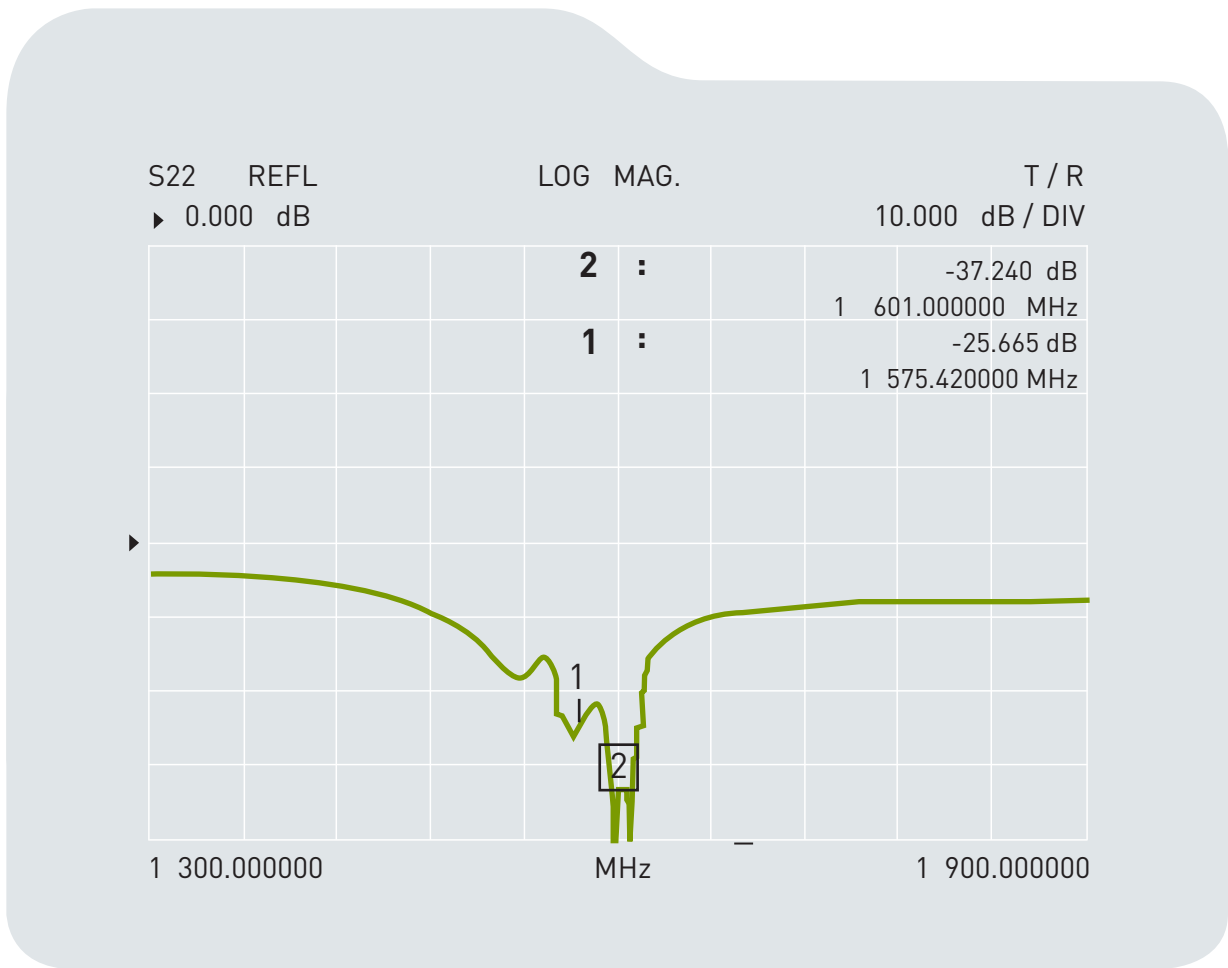

5. Drawing

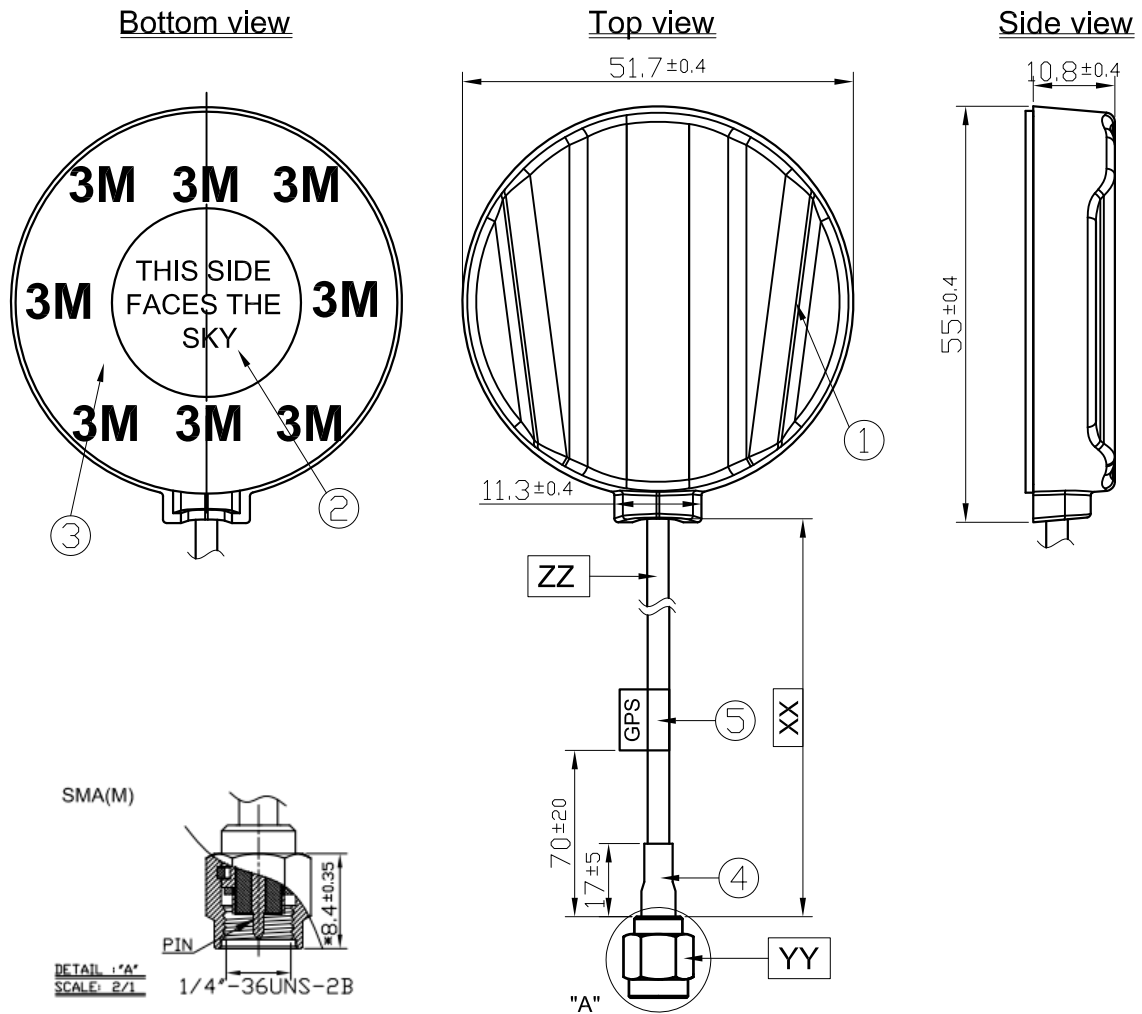

	Name	Material	Finish	QTY
1	Housing	ABS	Black	1
2	Round Label	Art Paper	White	1
3	Scotch Brand Acrylic Foam Tape	3M 4612	White Liner	1
4	Heat Shrink Tube RG174	PE	Black	1
5	GPS Label	Coated Paper	Orange	1

	Name	Spec	Finish	QTY
XX	Cable Length	3000mm ± 60mm		1
YY	Connector Type	SMA(M) ST	Gold	1
ZZ	Cable Type	RG174 Cable	Black	1

6. Packaging

1pcs antenna per small PE bag
80 small PE bag per box

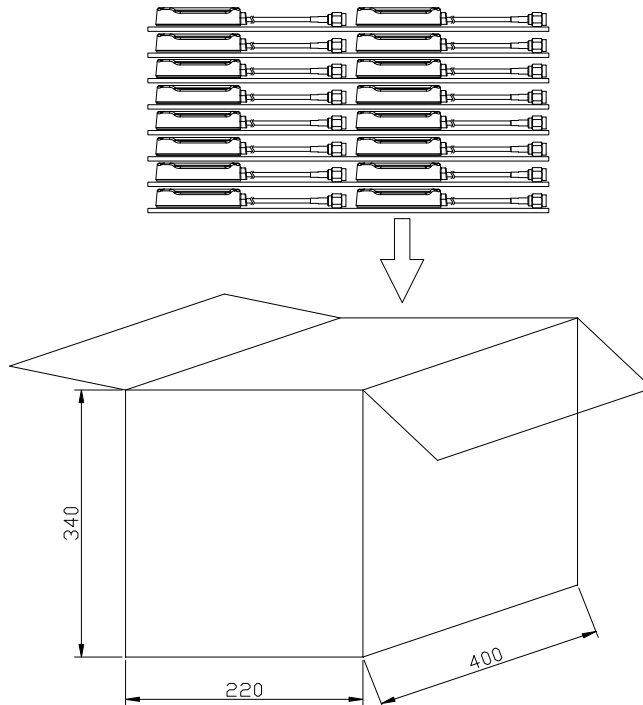
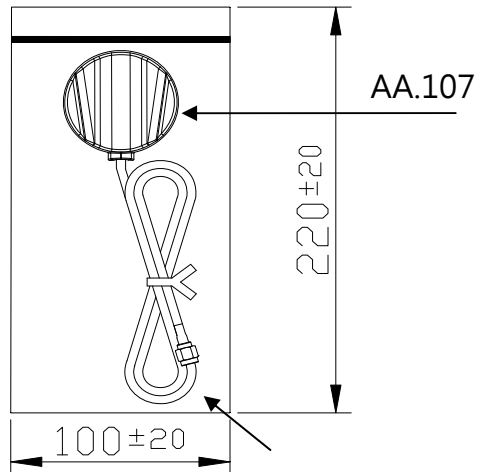

Taoglas makes no warranties based on the accuracy or completeness of the contents of this document and reserves the right to make changes to specifications and

product descriptions at any time without notice. Taoglas reserves all rights to this document and the information contained herein.

Reproduction, use or disclosure to third parties without express permission is strictly prohibited.
Copyright © Taoglas Ltd.