



AP.25M.07.0080A

## Specification

<b>Part No.</b>	AP.25M.07.0080A
<b>Product Name</b>	25mm One Stage GPS Active Patch Antenna Module with front-end Saw Filter
<b>Feature</b>	<ul style="list-style-type: none"> <li>Industry leading GPS antenna performance</li> <li>25mm*25mm*6mm</li> <li>80mm Ø1.13 I-PEX MHFI (U.FL)</li> <li>15dB LNA</li> <li>Wide Input Voltage 1.8V to 5.5V</li> <li>Low Power Consumption</li> <li>ROHS Compliant</li> </ul>

## 1. Introduction

The AP.25M is a one stage 25mm active patch antenna that has been designed specifically for embedded (inside device) integration with GPS receiver modules.

The AP.25M combines a 25\*25\*2mm advanced low profile ceramic patch antenna with a one stage LNA and a front-end SAW filter with ultra thin coaxial cable. It comes with it's own integrated ground-plane. The

front end SAW filter reduces the risks where there is a cellular transmitter nearby of interference from out of band frequencies which can cause LNA burn-out, saturation, or radiated spurious emissions.

The antenna can work on a wide input voltage from 1.8V to 5.5V with best in class power consumption figures.

If further tuning and optimization specific to a customer device is required Taoglas offers a custom tuned and optimized part service. Contact [sales@taoglas.com](mailto:sales@taoglas.com) for more information. Cables and connectors can be customized according to request.

This antenna system consists of two functional blocks, the LNA portion and the patch antenna.

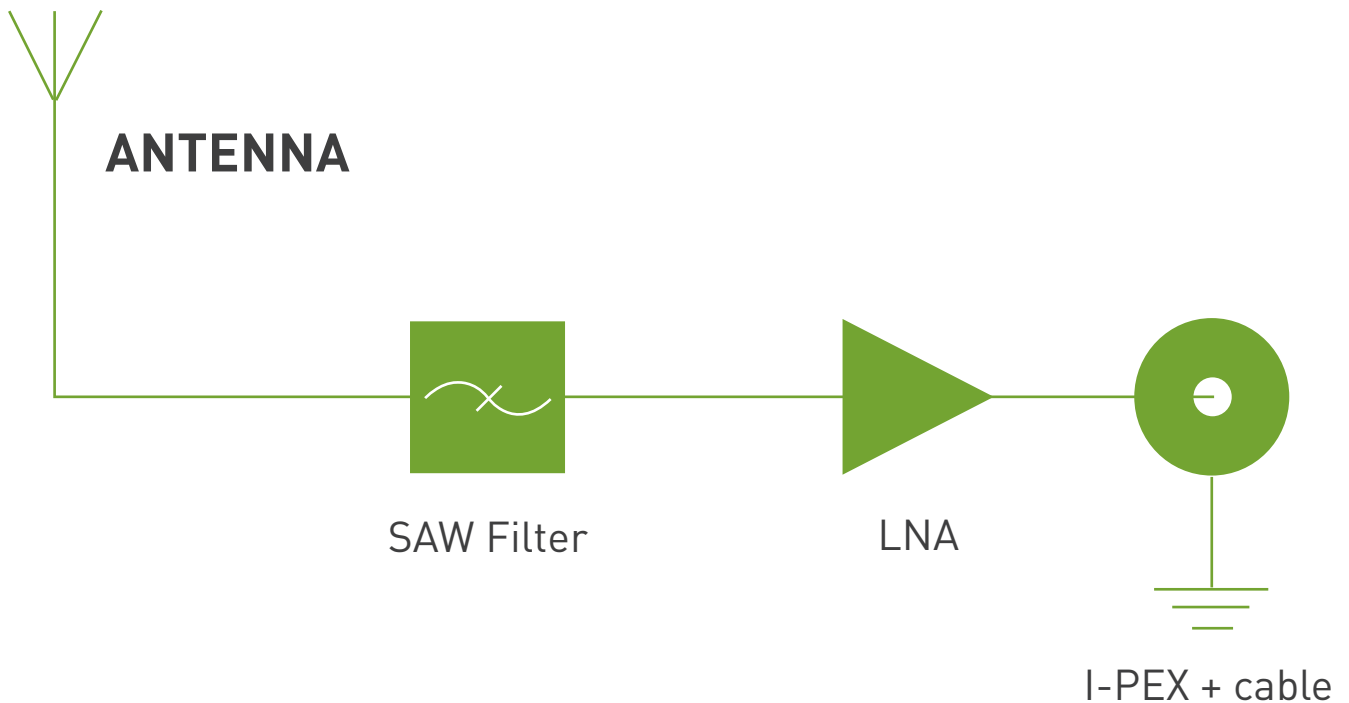

## 2. Specification

### 2.1 Patch Antenna

Parameter	Specification
Frequency	1575.42 ± 1.023MHz
Gain @ Zenith	+2.0 dBic Typ. @ Zenith
Polarization	RHCP
Axial Ratio	3.0dB max. @Zenith
Patch Dimension	25*25*2mm

### 2.2 LNA

Parameter	Specification
Frequency	1575.42 ± 1.023MHz
Outer Band Attenuation	F0=1575.42MHz F0±30MHz 3dB min. F0±50MHz 15dB min. F0±100MHz 23dB min.
Output Impedance	50Ω
Output VSWR	2.0 Max
Pout at 1dB Gain	Typ. -2dBm
Compression point	Min. -6dBm

#### LNA Gain, Power Consumption and Noise Figure

Voltage	LNA Gain (Typ)	Power Consumption(mA) Typ	Noise Figure Typ
Min. 1.8V	13dB	2mA	2.5dB
Typ. 3.0V	15dB	4mA	2.5dB
Max. 5.5V	16dB	9mA	2.6dB

### 2.3 Cable\* & Connector

Parameter	Specification
RF Cable	Coaxial Cable Ø 0.13 ± 0.1mm, length 80 ± 2.5mm
Connector	IPEX MHFI (U.FL)

### 3. LNA Gain and Out Band Rejection @3.0V

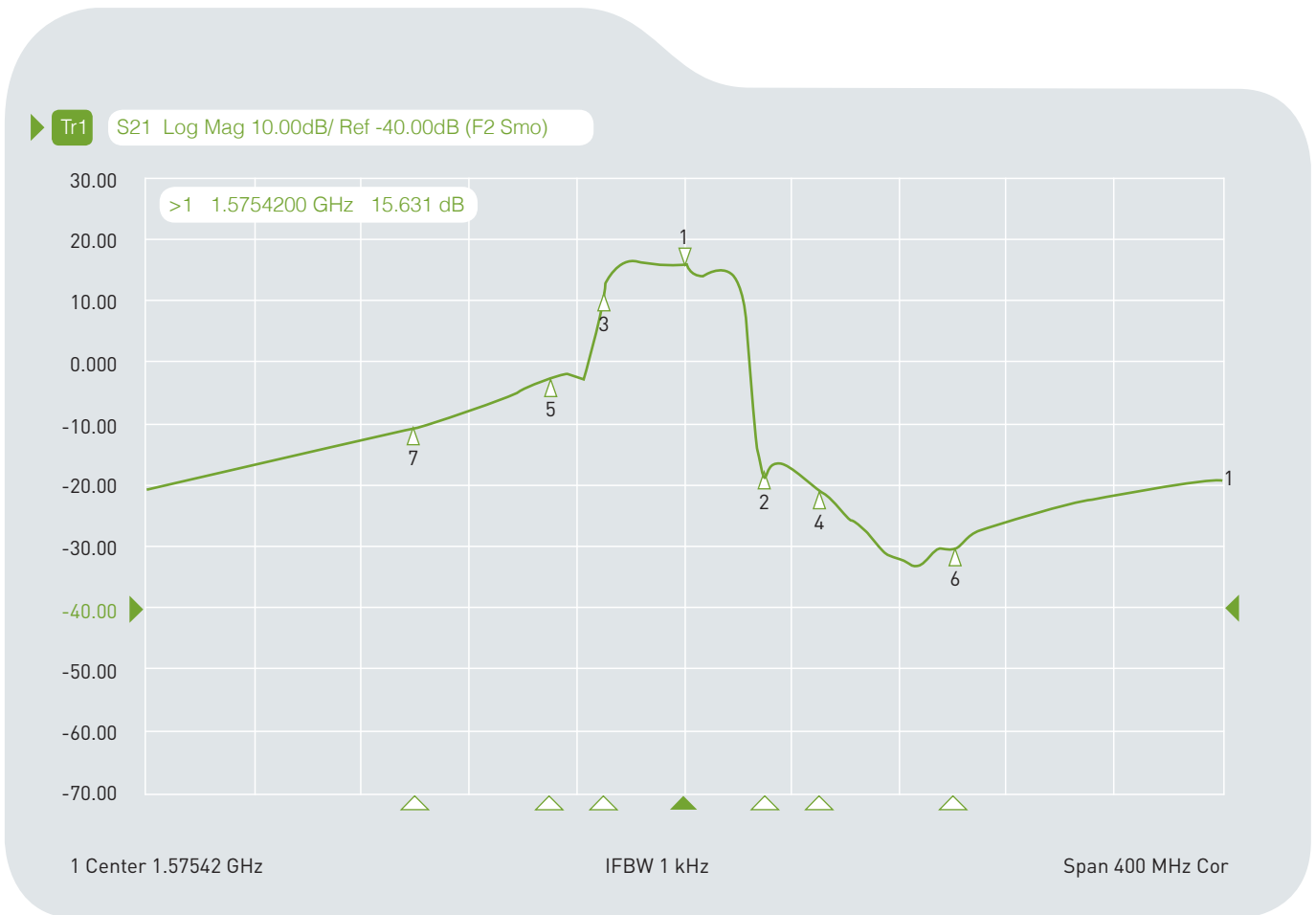

Cg1	Tr1	S21	>1	1.5754200 GHz	15.631	dB
Cg1	Tr1	S21	2	1.6054200 GHz	-17.657	dB
Cg1	Tr1	S21	3	1.5454200 GHz	11.265	dB
Cg1	Tr1	S21	4	1.6254200 GHz	-20.538	dB
Cg1	Tr1	S21	5	1.5254200 GHz	-2.7107	dB
Cg1	Tr1	S21	6	1.6754200 GHz	-30.353	dB
Cg1	Tr1	S21	7	1.4754200 GHz	-10.799	dB

## 4. LNA Noise Figure @3.0V

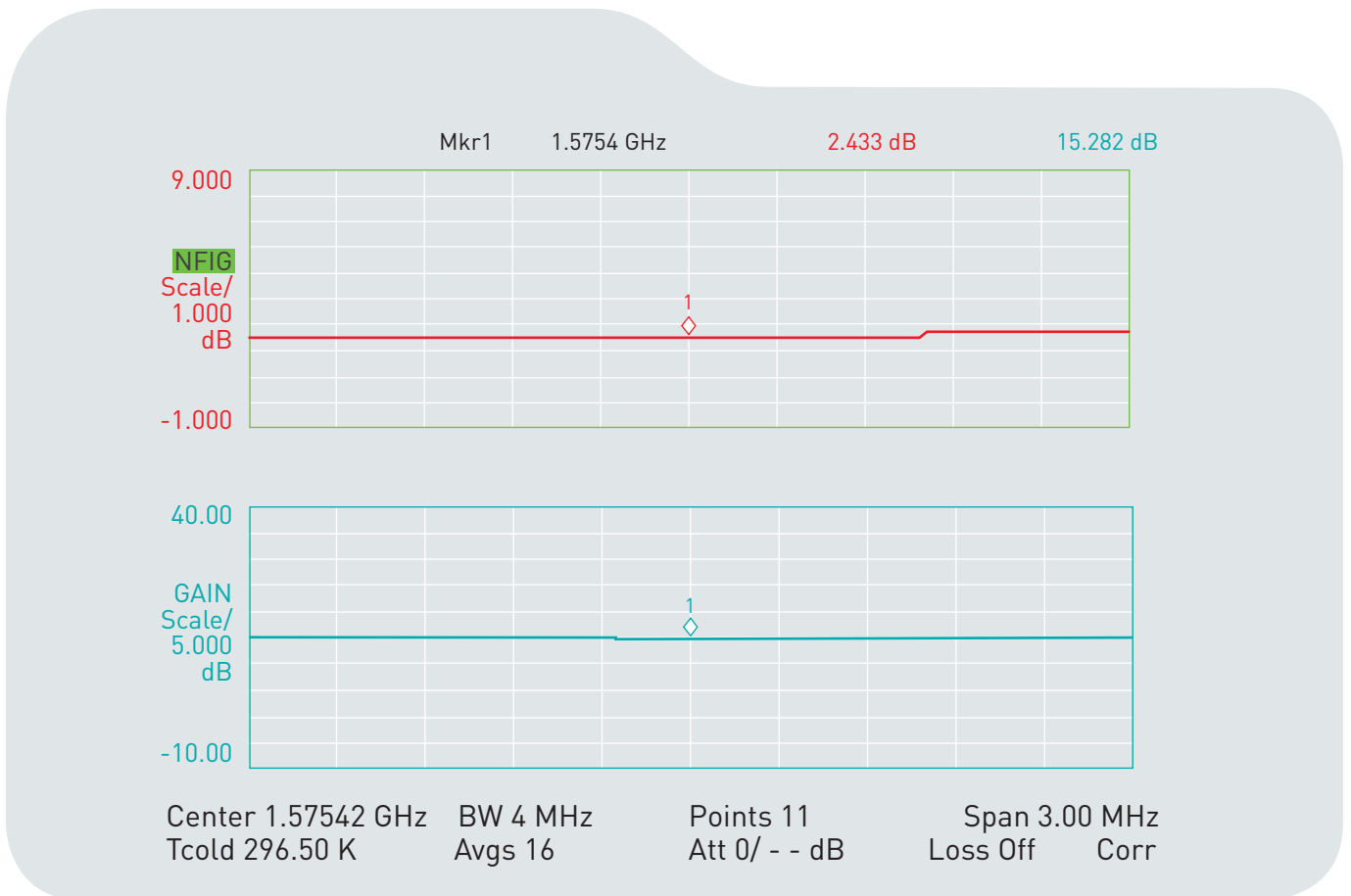

## 5. Total Specification (through Antenna, LNA, Cable and Connector)

Parameter	Specification
Frequency	1575.42 ± 1.023MHz
Gain	At 3V: 17 ± 3dBic (At 90°)
Output Impedance	50Ω
Polarization	RHCP
Output VSWR	Max 2.0
Operation Temperature	-40°C to + 85°C
Storage Temperature	-40°C to + 85°C
Relative Humidity	40% to 95%
Input Voltage	Min. 1.8V, Typ. 3.0V, Max. 5V
Antenna	25*25*6mm

## 6. Radiation Patterns

### 6.1 XZ Plane Radiation

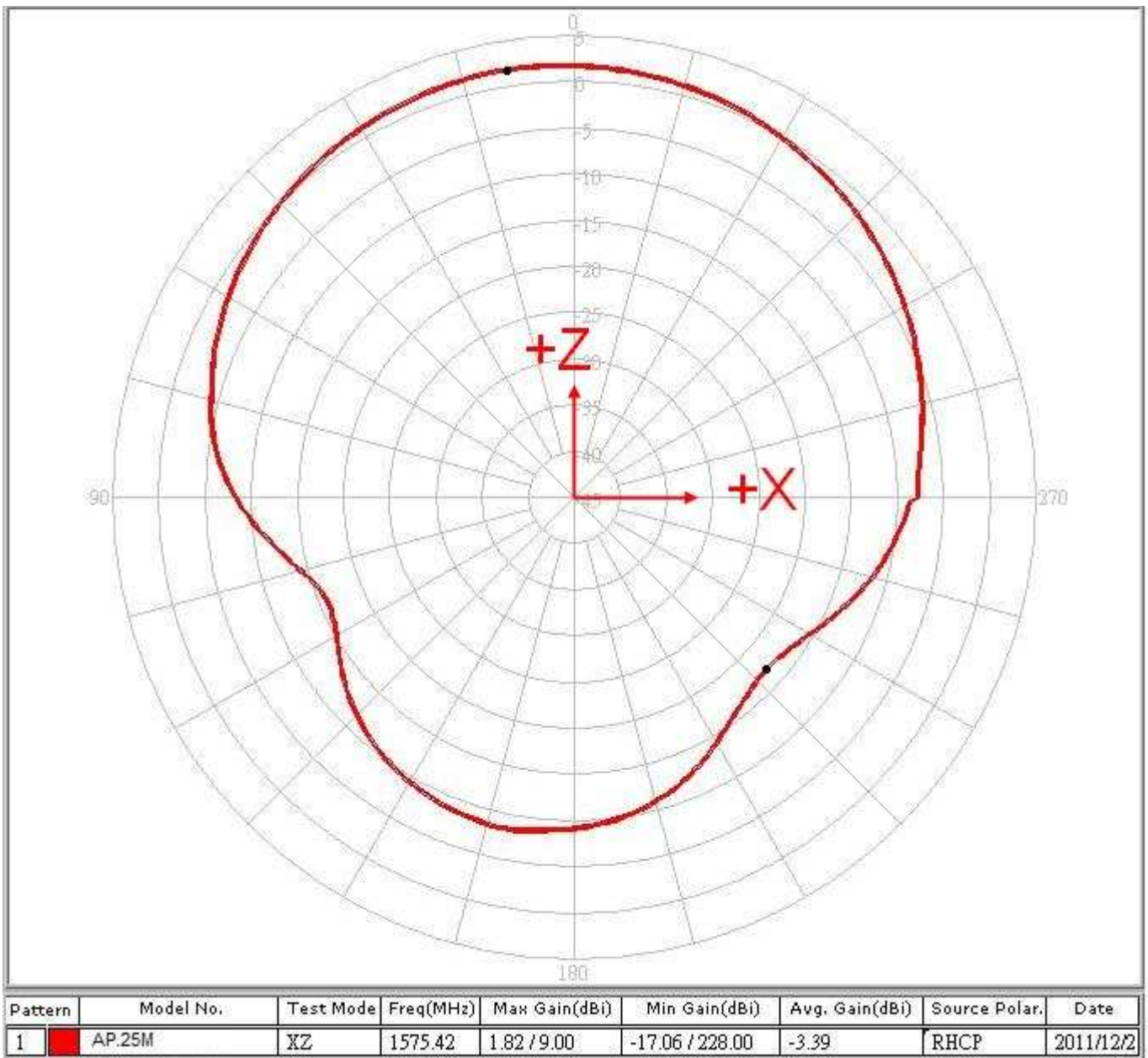

## 6.2 YZ Plane Radiation

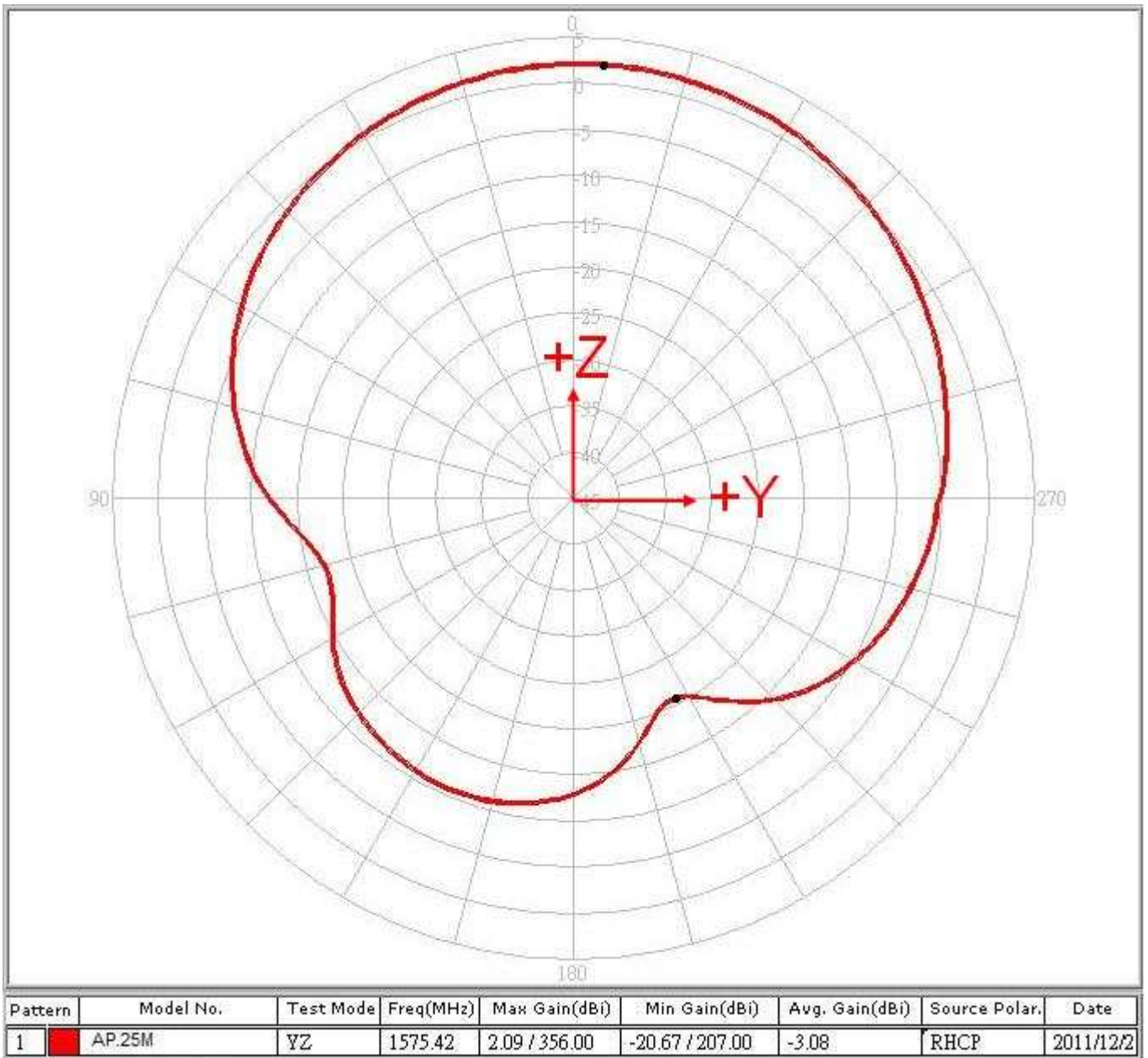

### 6.3 XY Plane Radiation

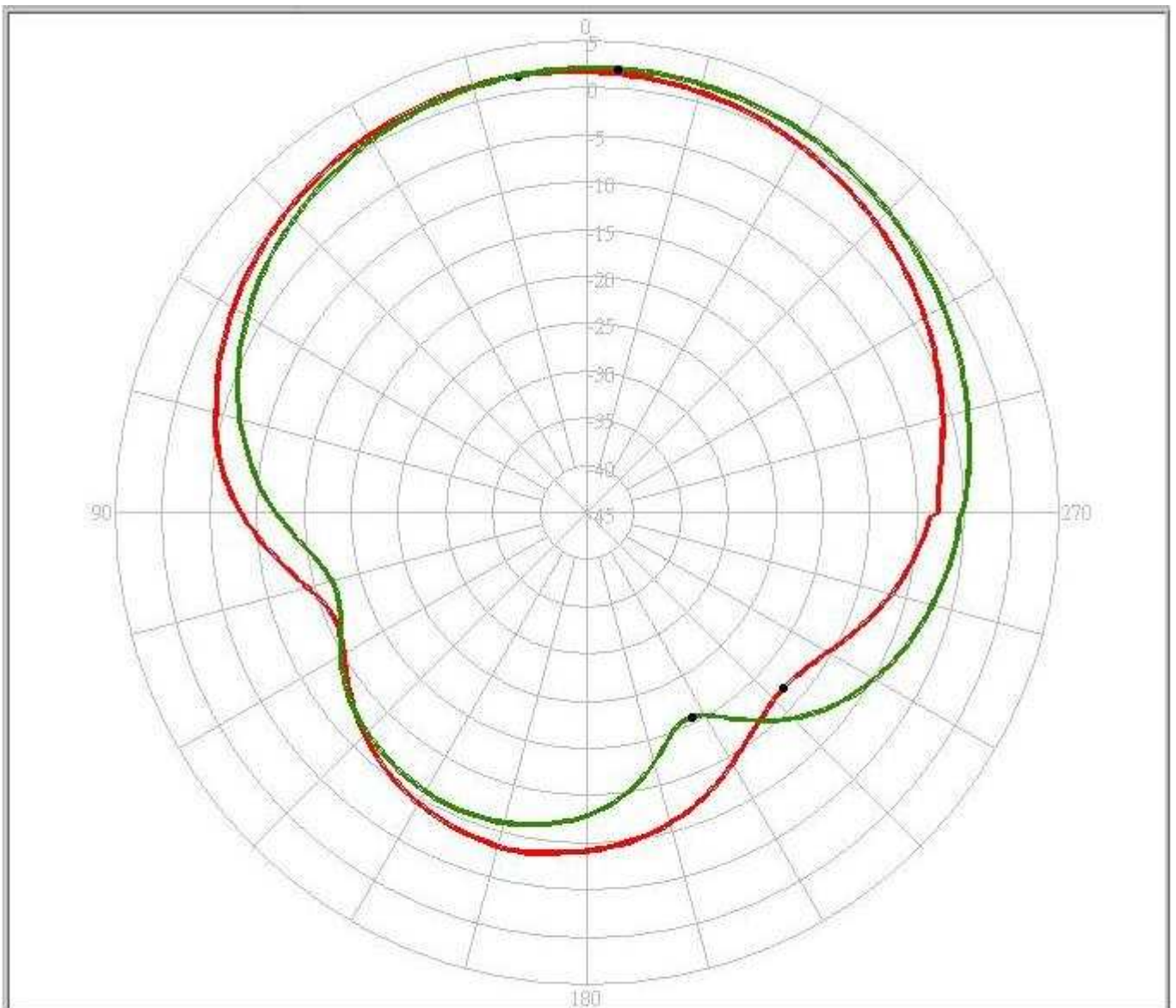



Pattern	Model No.	Test Mode	Freq(MHz)	Max Gain(dBi)	Min Gain(dBi)	Avg. Gain(dBi)	Source Polar.	Date
1	AP.25M	XZ	1575.42	1.82 / 9.00	-17.06 / 228.00	-3.39	RHCP	2011/12/2
2	AP.25M	YZ	1575.42	2.09 / 356.00	-20.67 / 207.00	-3.08	RHCP	2011/12/2

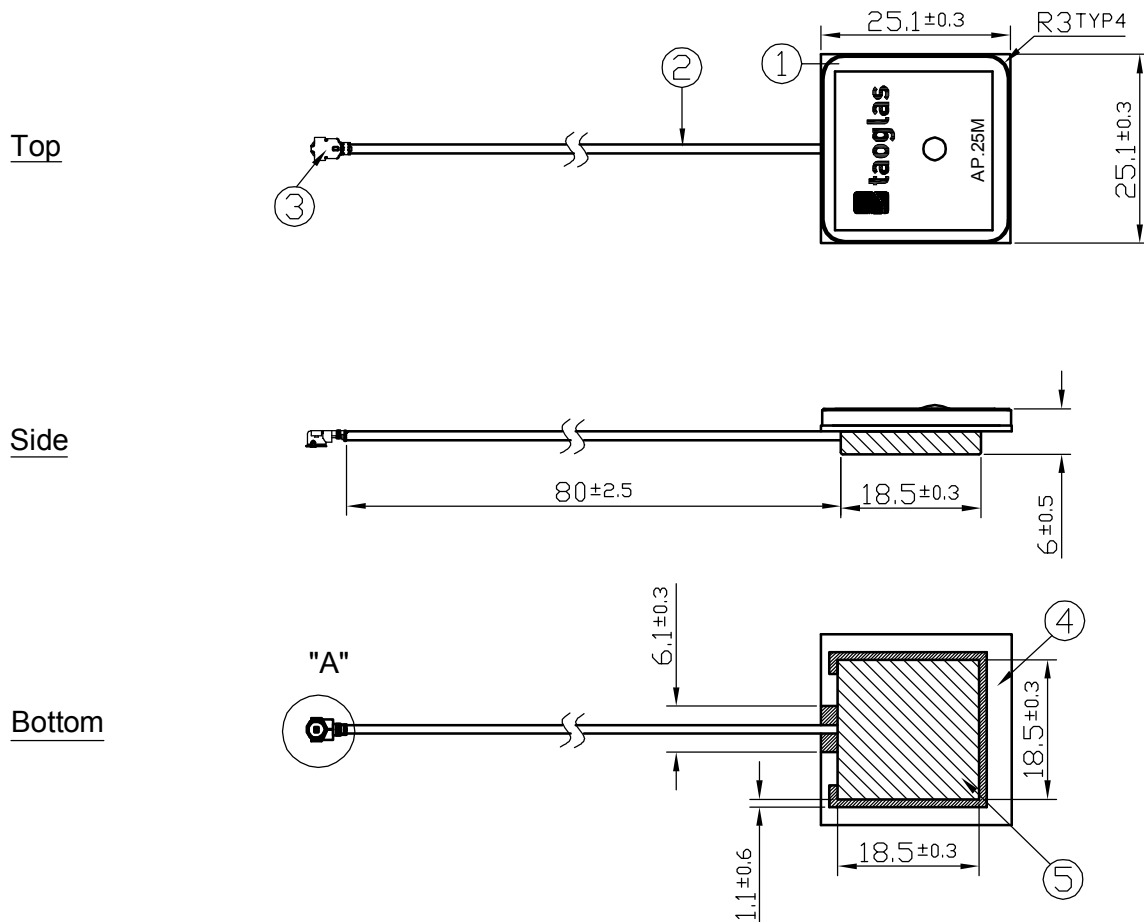

## 7. Technical Drawing



### NOTE:

1. Soldered area 
2. Shielding case area 
3. All material must be RoHS compliant.
4. The connector orientation has a fixed position to the antenna as per drawing.

	Name	P/N	Material	Finish	QTY
1	AP.25M Patch (25*25*2mm)	AP.25M	Ceramic	Clear	1
2	1.13 Cable	OD.113.CM	PVC	Gray	1
3	IPEX MHF1	IPEX.MHFI.113	Brass	Gold	1
4	PCB		FR4 0.8t	Green	1
5	Shielding Case		(Tin) SPTE	Tin Plated	1

## 7.1 Connector Drawing

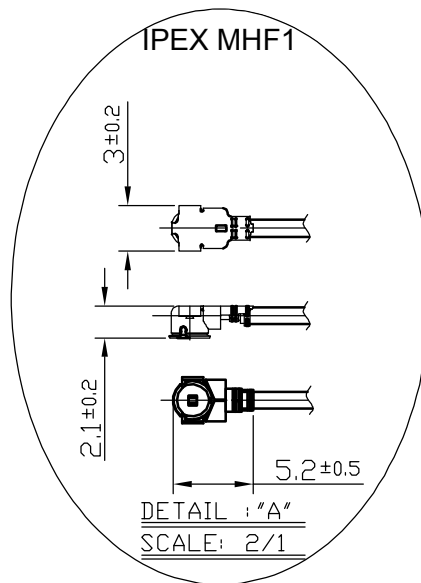

## 8. Plugs Usage Precautions

### 8.1 Mating / unmating

(1) To disconnect connectors, insert the end portion of I-PEX under the connector flanges and pull off vertically, in the direction of the connector mating axis.

(2) To mate the connectors, the mating axes of both connectors must be aligned and the connectors can be mated. The "click" will confirm fully mated connection.

Do not attempt to insert on an extreme angle.

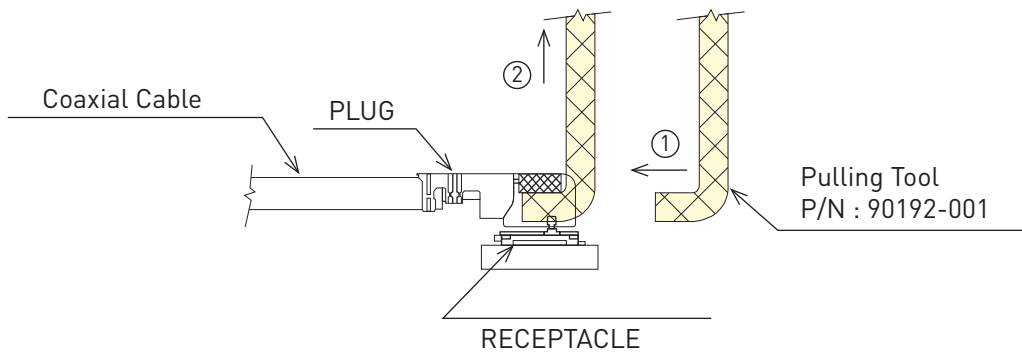

### 8.2 Pull forces on the cable after connectors are mated

After the connectors are mated, do not apply a load to the cable in excess of the values indicated in the diagram below.

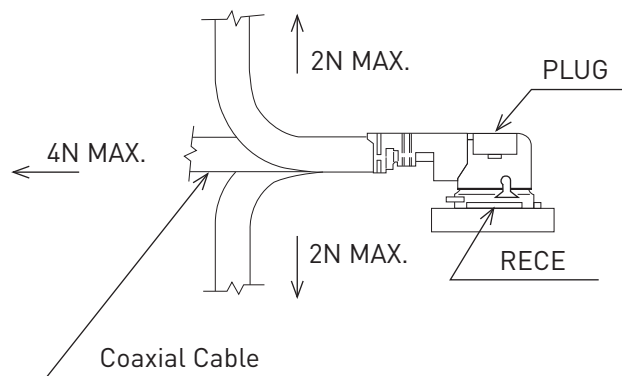

## 9. Packaging

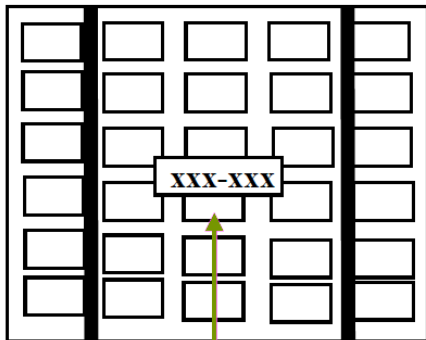

- \*Packaged in Tray with Foam
- \*One Tray = 60 pieces
- \*6 Trays per Section = 360 pcs

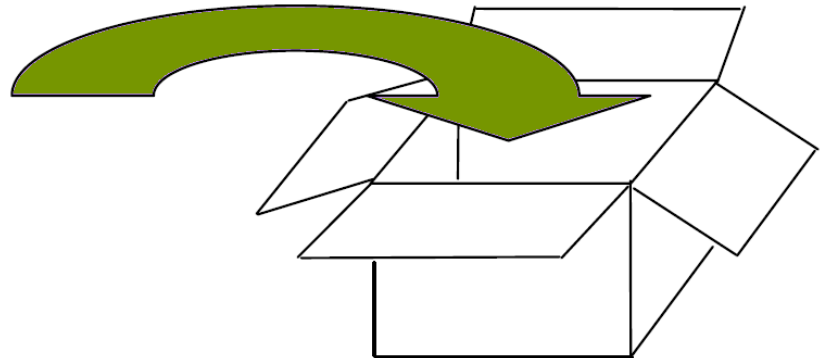

- \*Each Carton contains 3 Sections
- \*1080 pieces per Carton

Taoglas makes no warranties based on the accuracy or completeness of the contents of this document and reserves the right to make changes to specifications and

product descriptions at any time without notice.

Taoglas reserves all rights to this document and the information

contained herein. Reproduction, use or disclosure to third parties without express permission is strictly prohibited. Copyright © 2012, Taoglas Ltd.