



Front



Back

Warrior

PA.710.A

Specification

Patent Pending

Part No.	PA.710.A
Product Name	Warrior Ultra Wide-Band LTE/Cellular/CDMA SMT Antenna For 2G/3G/4G applications LTE / GSM / CDMA /DCS /PCS / WCDMA / UMTS / HSDPA / GPRS / EDGE /IMT, 698MHz to 960MHz, 1710MHz to 2690Mhz
Feature	High efficiency Wide-Band Antenna Patent Pending Surface Mount Technology 40 x 6 x 5mm size RoHS Compliant



1. Introduction

The Warrior, the revolutionary patent pending PA.710A is a 2G/3G/4G, High Efficiency SMT Ceramic antenna, operating at 698MHz to 960MHz and 1710MHz to 2690MHz. It uses high grade custom ceramic material and new design

techniques to deliver the highest efficiencies on all bands when mounted on the device's main PCB. The exceptional wide-band response means it is the ideal antenna for all LTE applications that also need high efficiency and backward

compatibility for 2G and 3G globally on all lower and upper bands.

The PA.710A is delivered on tape and reel and mounted securely during the device PCB reflow process.

1.1 Key Advantages

1. Highest efficiency in a small size, i.e. 40mm*6mm*5mm.

A comparative antenna, for example metal/FR4/FPC/whip/rod/helix, would have much reduced efficiency in this configuration due to their different dielectric constants.

Very high efficiency antennas are critical to 3G and 4G devices ability to deliver the stated data-speed rates of systems such as HSPA and LTE.

2. More resistant to detuning compared to other antenna integrations.

If tuning is required it can be tuned for the device environment using a matching circuit, or other techniques on the main PCB itself. There is no need for new tooling, thereby saving money if customization is required.

3. Highly reliable and robust

Its predecessors the PA.25A and PA700A antennas are used by the world's leading automotive makers in extremely challenging environments. The antenna meets all temperature and mechanical specs required (vibration, drop tests etc)

4. Easy to integrate.

Other antenna designs come in irregular shapes and sizes making them more difficult to integrate.

5. Surface Mount Technology (Directly On-Board)

antenna saves on labor, cable and connector costs, leads to higher integration yield rates, and reduces losses in transmission.

6. Minimum Transmission and Reception Losses

these are kept to absolute minimum resulting in much improved OTA (over the air), i.e. TRP (Total Radiated Power)/TIS (Total Isotropic Radiation), device performance compared to similar efficiency cable and connector antenna solutions. This means it is an ideal antenna to be used for devices that need to pass for example USA carrier network approvals

7. RSE Reductions

Will help to eliminate radiated spurious emission failures compared to other antenna technologies as the required

layout for the antenna can deliver natural isolation between the onboard noise and the antenna itself.

Also the antenna can be matched better to the system with the matching circuit function.

8. High Gain in Both Polarization Planes

Achieves moderate to high gain in both vertical and horizontal polarization planes. This feature is very useful in certain wireless communications where the antenna orientation is not fixed and the reflections or multipath signals may be present from any plane.

In those cases the important parameter to be considered is the total field strength, which is the vector sum of the signal from the horizontal and vertical polarization planes at any instant in time.

2. Specification

Electrical

Antenna	PA710 Warrior			
Standard	2G/3G/4G			
Operation Frequency (MHz)	698~960MHz	1710~2170MHz	2300~2400MHz	2490~2690MHz
Peak Gain	1.0dBi	3.2dBi	3.5dBi	3.5dBi
Average Gain	-2.3 dB	-1.5dB	-1.8dB	-1.5dB
Efficiency	60%	70%	65%	70%
VSWR	<3.0:1			
Impedance	50Ω			
Polarization	Linear			
Radiation Properties	Omni-directional			
Max Input Power	5 W			

* The Warrior PA710 antenna performance was measured with 120x45mm ground plane.

Mechanical

Dimensions (mm)	40 x 6 x 5 mm
Material	Ceramic
Termination	Ag (environmental-friendly Pb free)
EVB Connector	SMA-Female

Environmental

Operation Temperature	-40°C to 85°C
Storage Temperature	-40°C to 105°C
Relative Humidity	Non-condensing 65°C 95% RH
RoHs Compliant	Yes

3. Test Set Up



Figure 1. Impedance measurements (left hand) and peak gain, average gain, efficiency and radiation pattern measurements (right hand)

4. Antenna Parameters

4.1 Return Loss

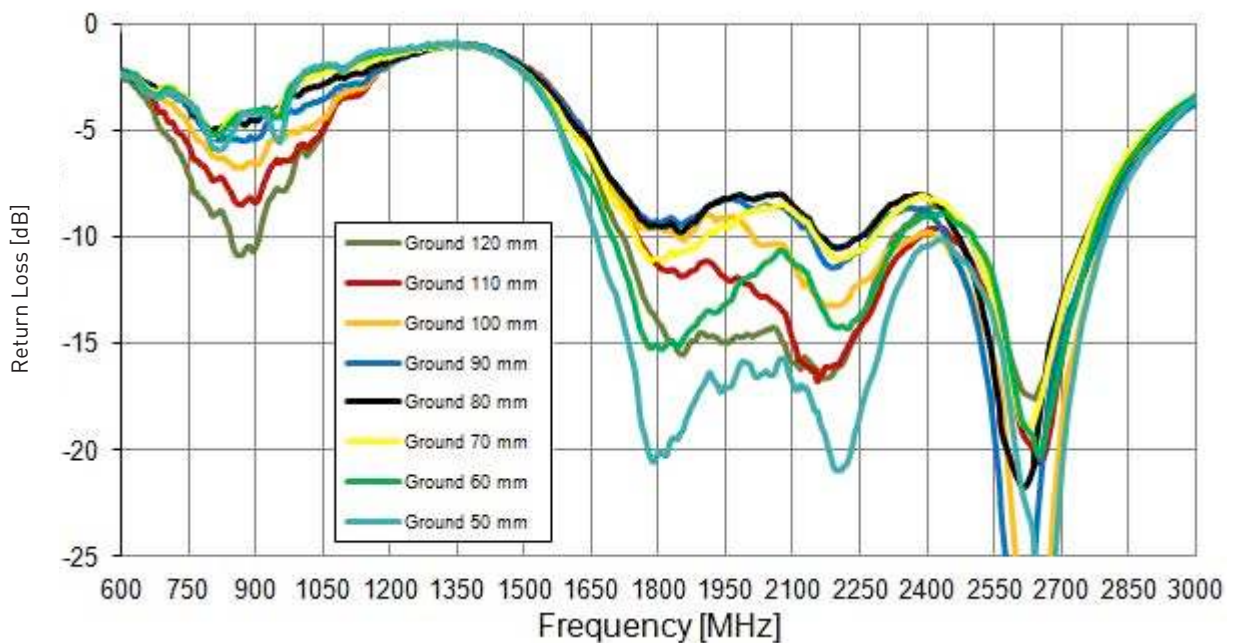

Figure 2. Return Loss of the Warrior PA710 LTE antenna

4.2 VSWR

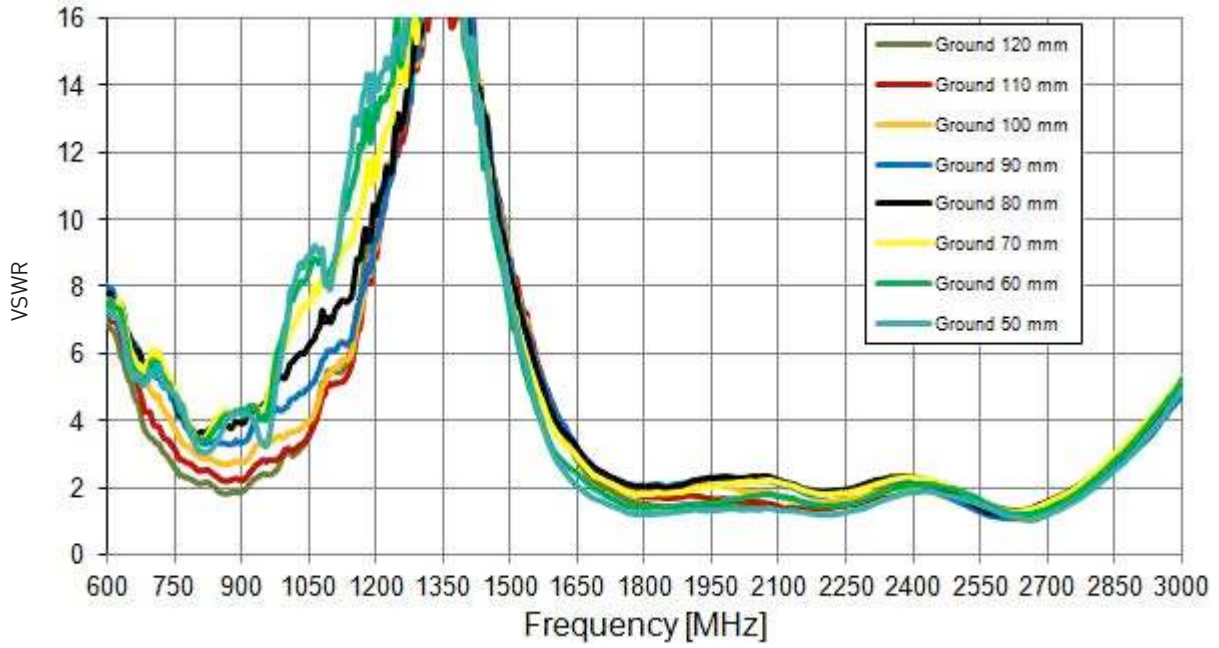

Figure 3. VSWR of the Warrior PA710 LTE Antenna

4.3 Efficiency

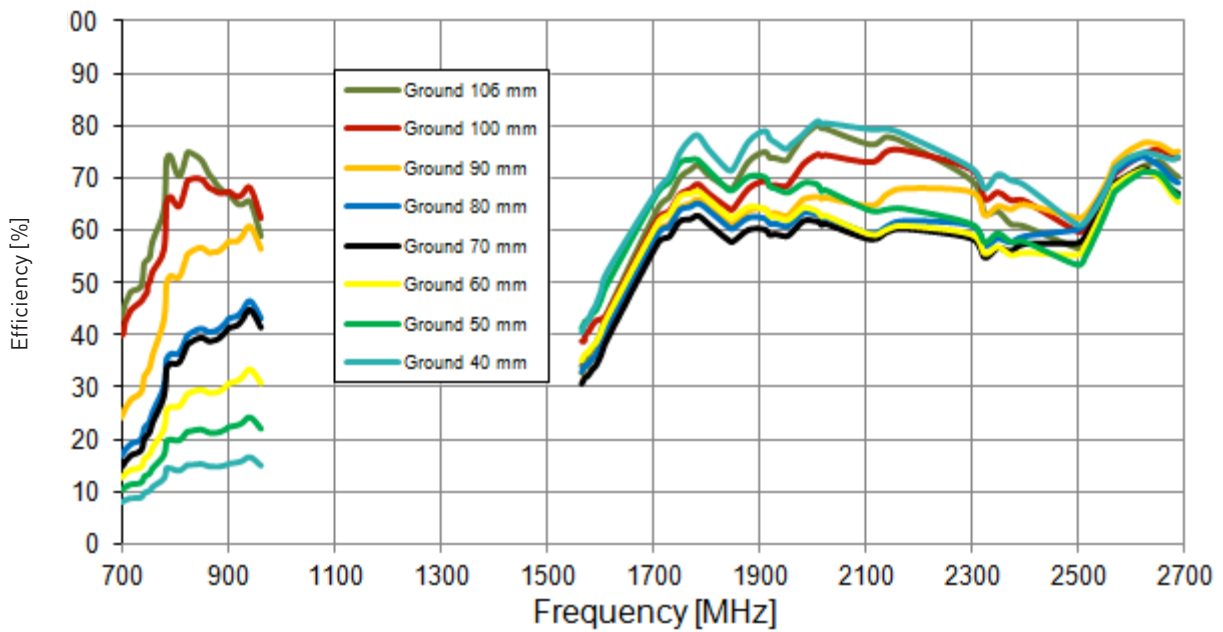

Figure 4. Efficiency of the Warrior PA710 LTE Antenna

4.4 Peak Gain

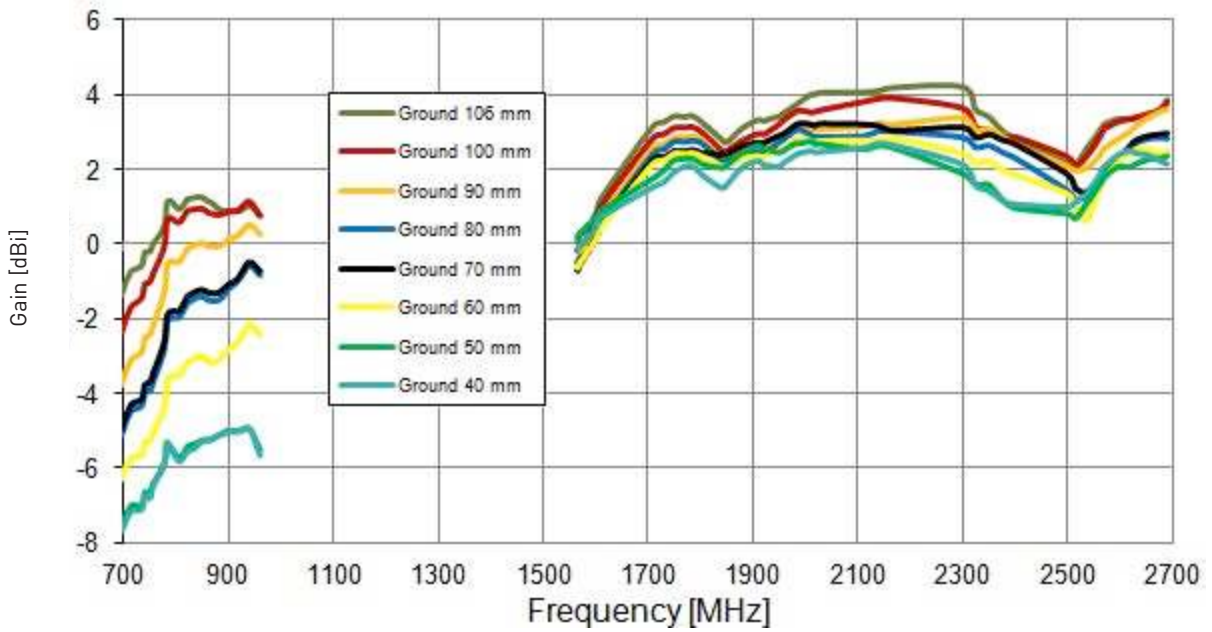

Figure 5. Peak Gain of the Warrior PA710 LTE Antenna

4.5 Average Gain

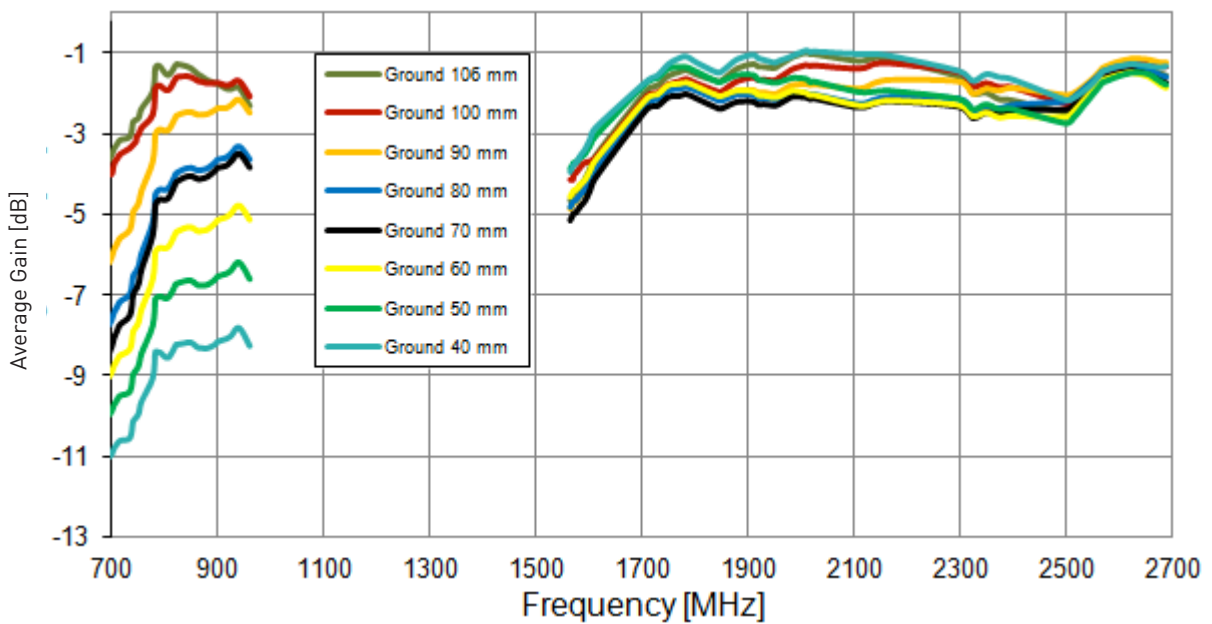

Figure 6. Average Gain of the Warrior PA710 LTE Antenna

4.6 3D Radiation Pattern (measured on 120*45mm EVB)

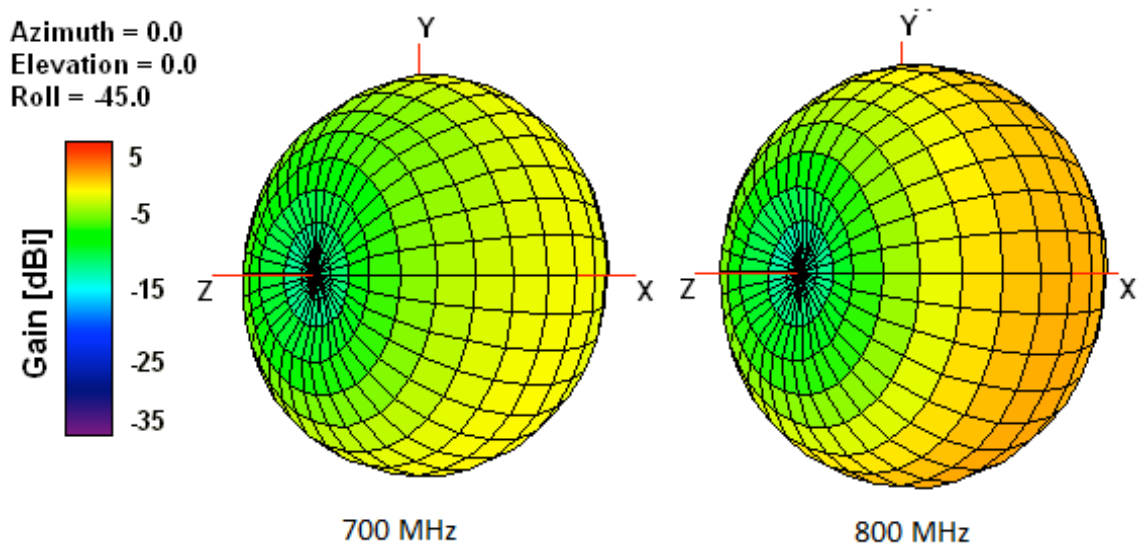

Figure 7. 3D Radiation Pattern at 700 and 800 MHz of the Warrior PA710 Antenna

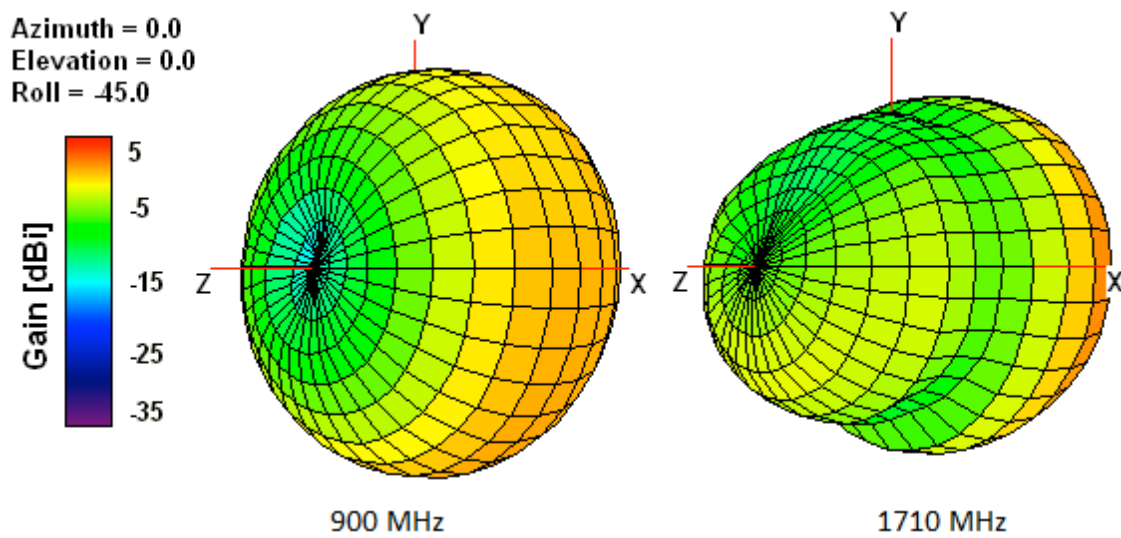

Figure 8. 3D Radiation Pattern at 900 and 1700 MHz of the Warrior PA710 Antenna

4.6 3D Radiation Pattern (measured on 120*45mm EVB)

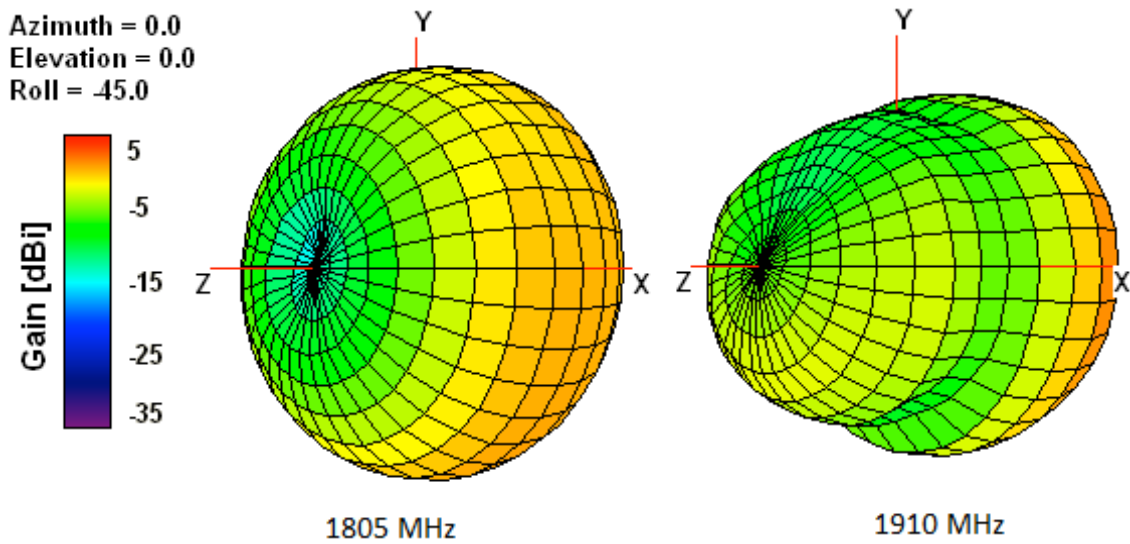

Figure 9. 3D Radiation Pattern at 1805 and 1910 MHz of the Warrior PA710 Antenna

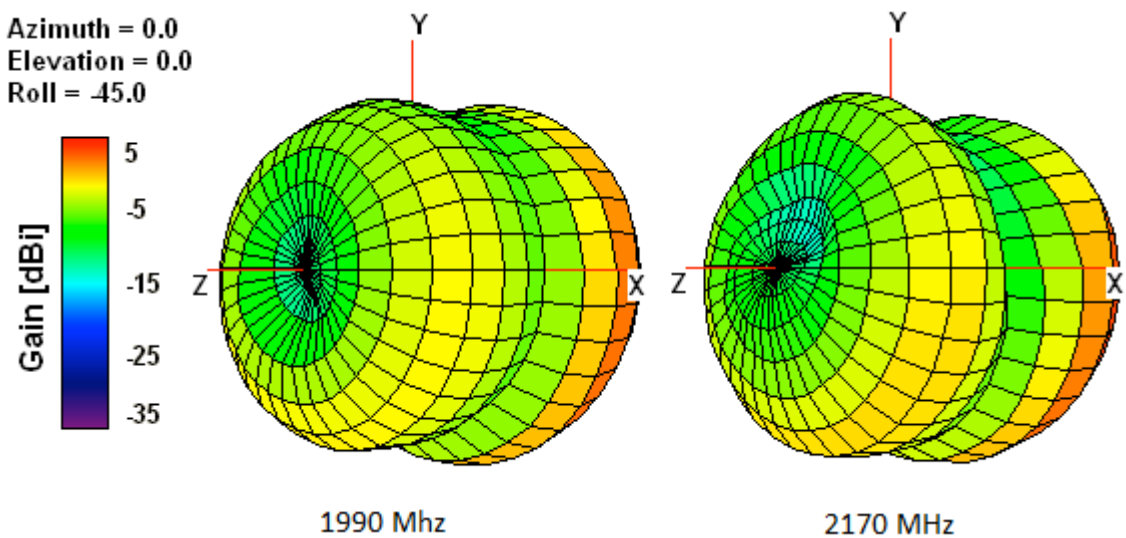

Figure 10. 3D Radiation Pattern at 1990 and 2170 MHz of the Warrior PA710 Antenna

4.6 3D Radiation Pattern (measured on 120*45mm EVB)

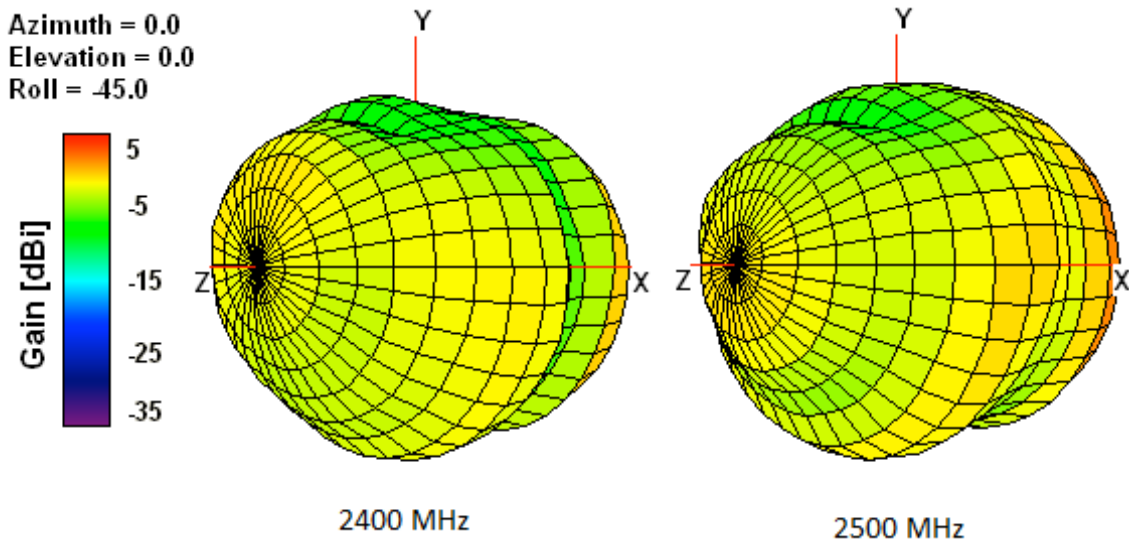

Figure 11. 3D Radiation Pattern at 2500 and 2600 MHz of the Warrior PA710 Antenna

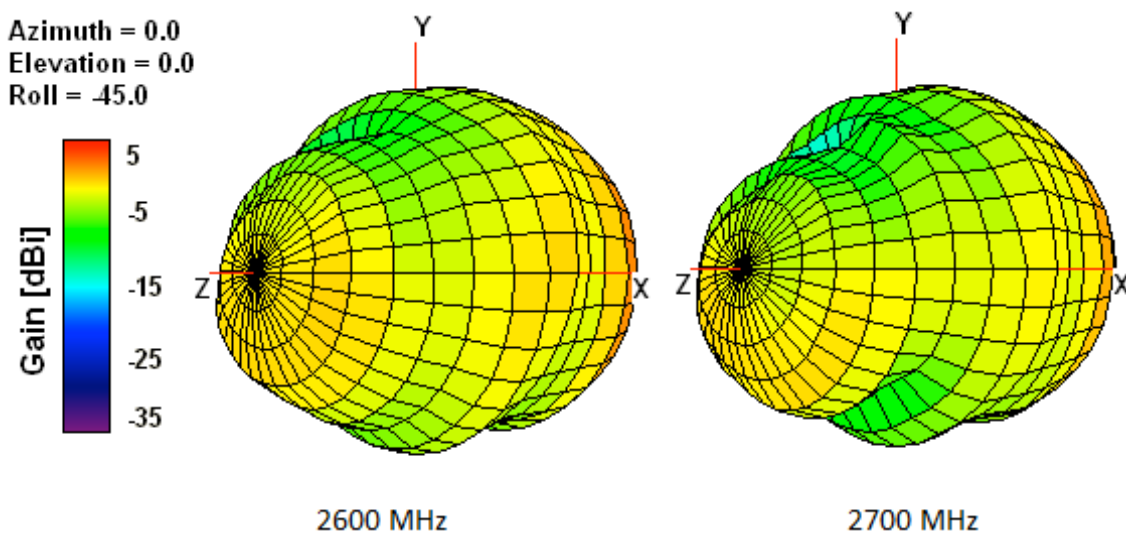
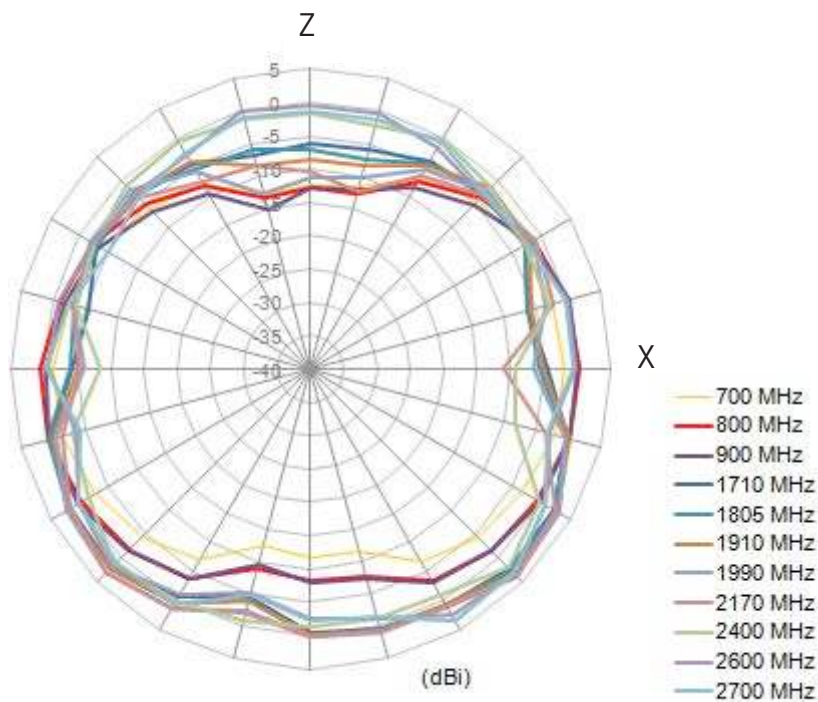
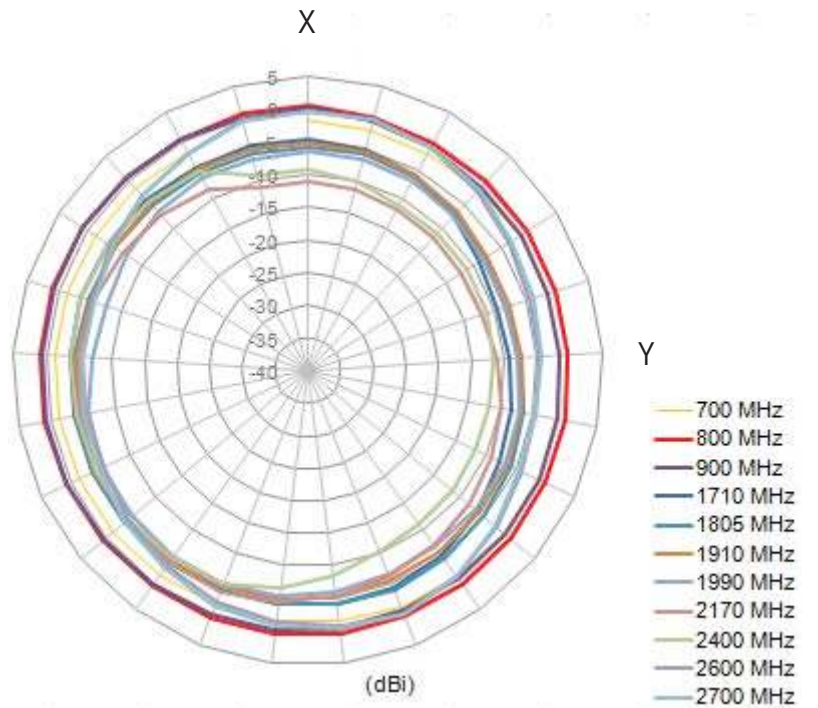

Figure 12. 3D Radiation Pattern at 2700 and 2800 MHz of the Warrior PA710 Antenna

4.7 2D Radiation Pattern (measured on 120*45mm EVB)



4.7 2D Radiation Pattern (measured on 120*45mm EVB)

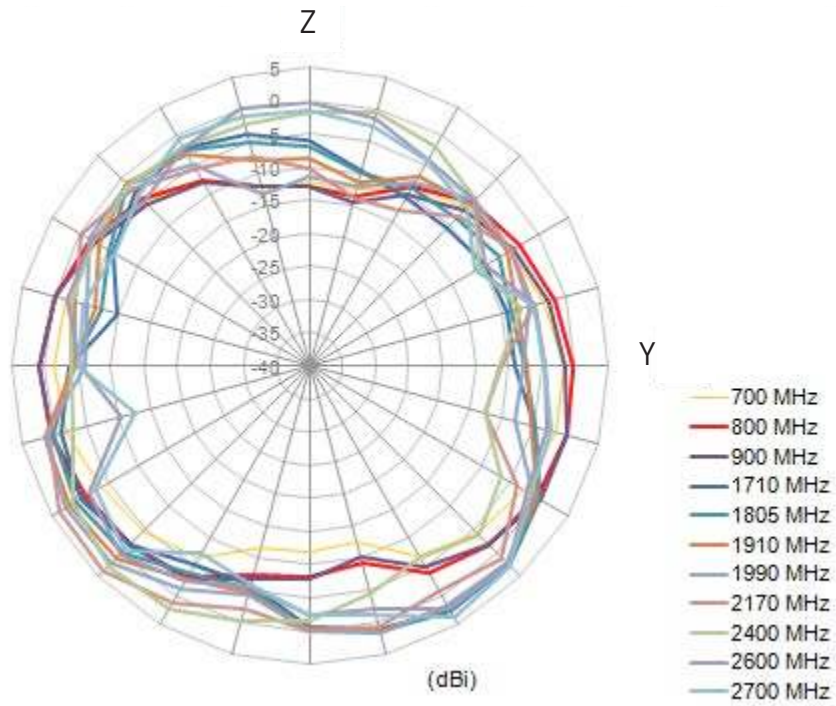

Figure 13. 2D Radiation Pattern of the Warrior PA710 Antenna

5. Mechanical Drawing

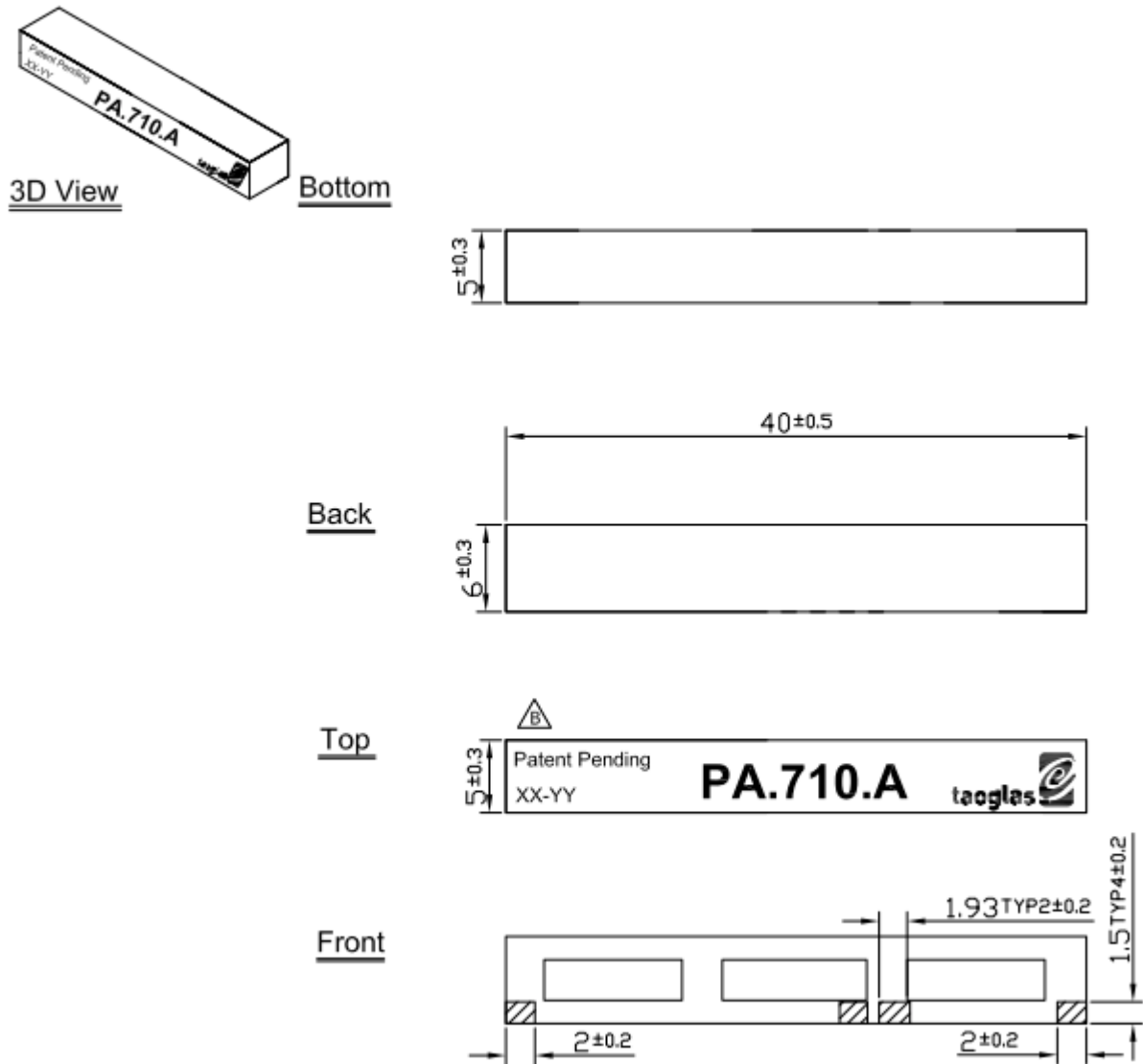

Figure 14. Mechanical Drawing of the Warrior PA710 Antenna.

6. Layout Dimensions

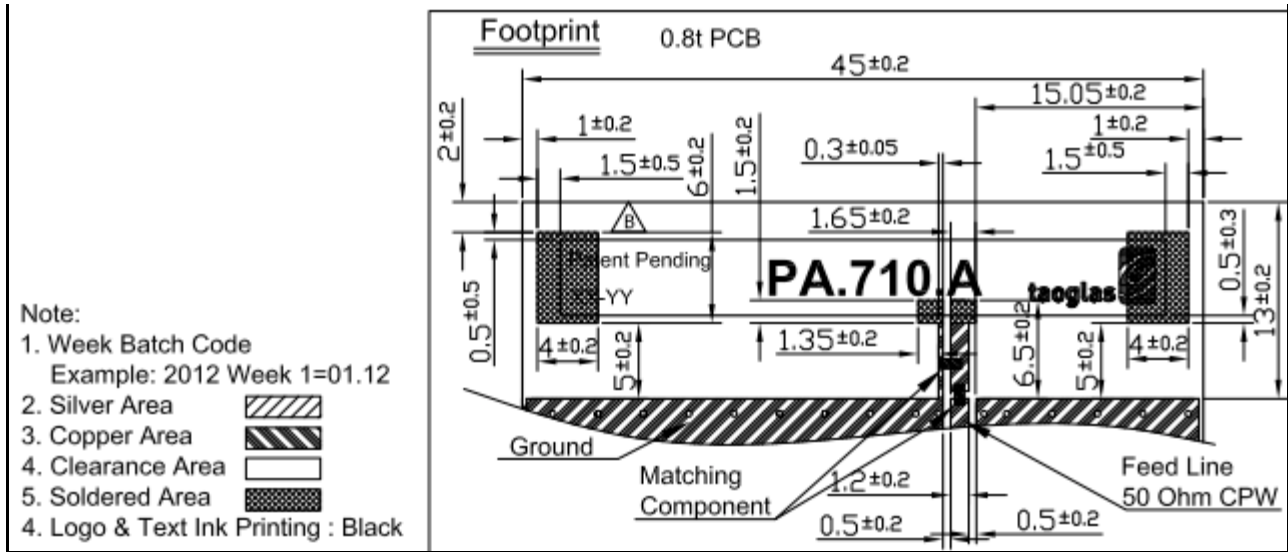

Figure 15. Layout dimensions of the Warrior PA710 Antenna

7. EVB Dimensions

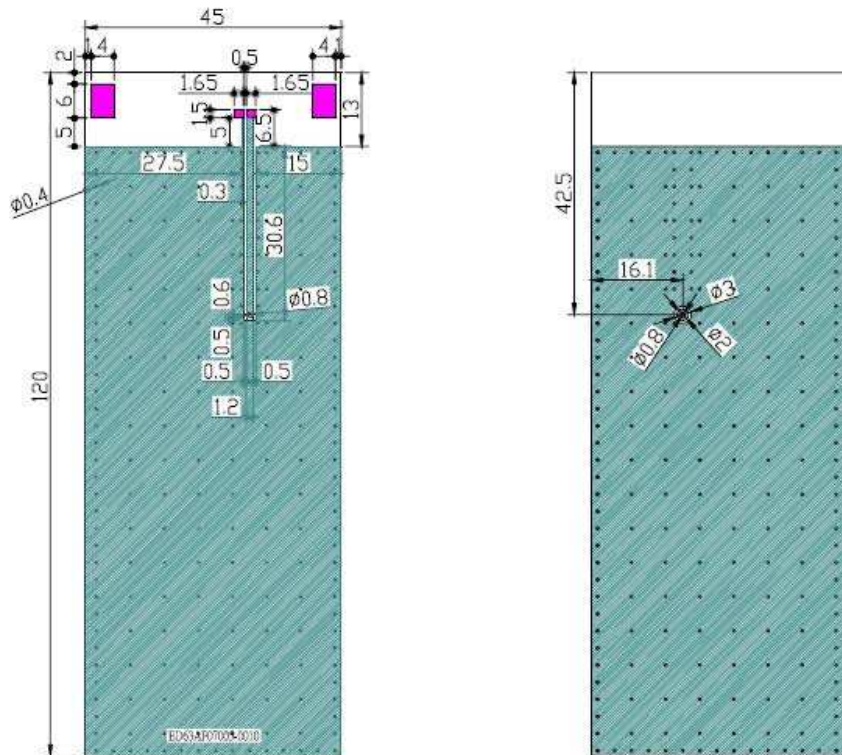
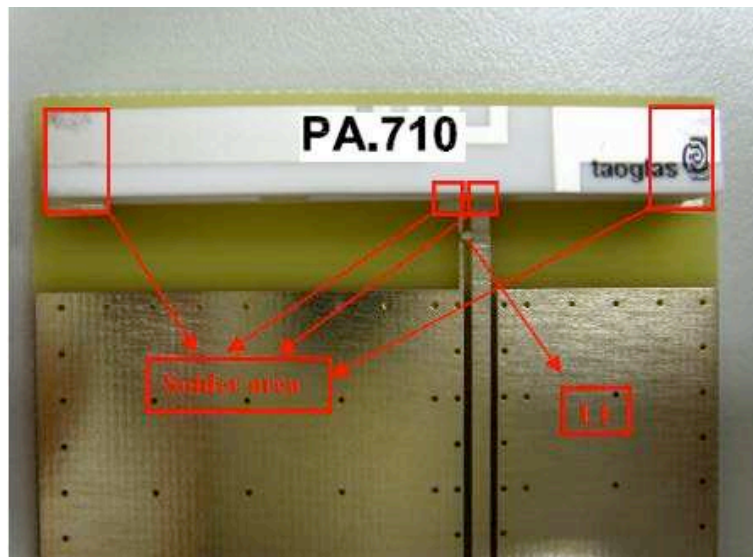
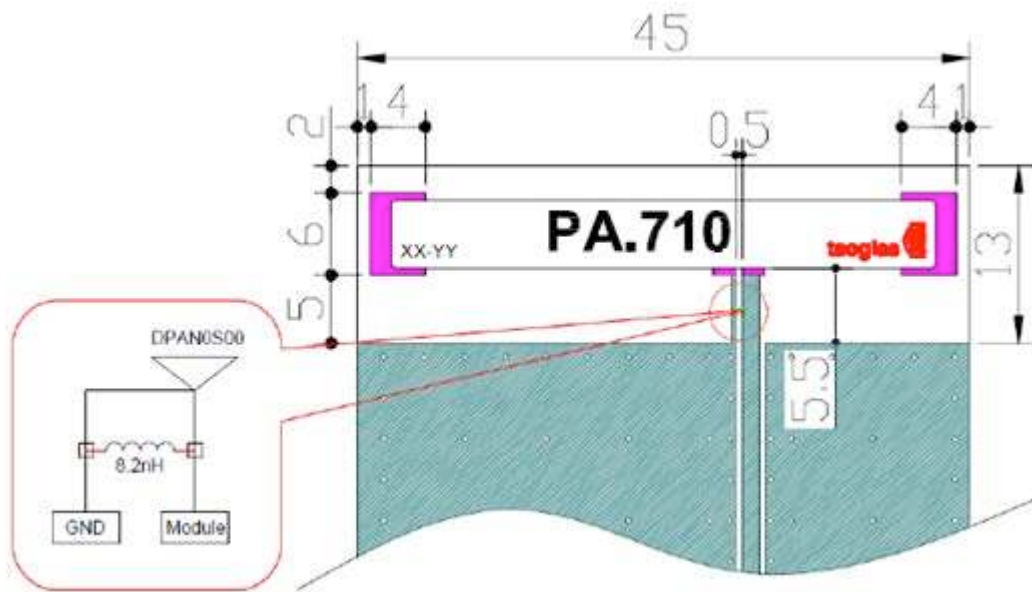

Figure 16. EVB Dimensions of the Warrior PA710.

8. Matching Circuit



Circuit Symbol

L1

Size

0402

Description

8.2nH Inductor (MLK1005S8N2D)

Figure 17. Recommended matching circuit

9. Packaging

Blister tape to IEC 286-3, Polyester

Pieces / Tape = 450

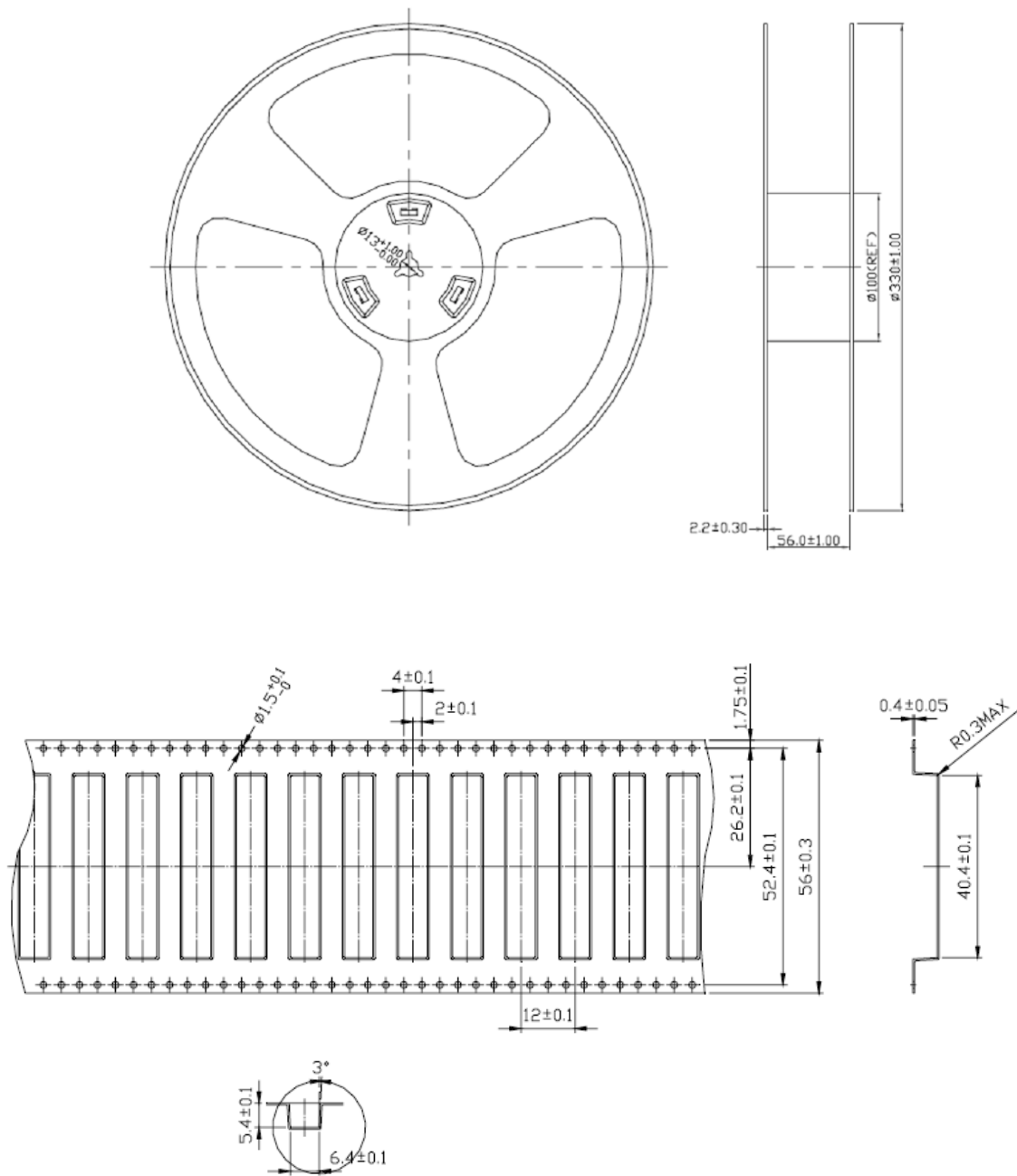

10. Recommended Reflow Temperature Profile

The PA.710 can be assembled following either Sn-Pb or Pb-Free assembly processes. The recommended soldering temperatures are as follows:

Phase	Profile Features	Sn-Pb Assembly	Pb-Free Assembly (SnAgCu)
Ramp-Up	Avg Ramp-Up Rate (T _{smax} to T _P)	3°C/second (max)	3°C/second (max)
Preheat	Temperature Min (T _{smin}) Temperature Max (T _{smax}) Time (t _{smin} to t _{smax})	100°C 150°C 60-120 seconds	100°C 150°C 60-120 seconds
Reflow	Temperature (T _L) Total Time Above T _L b(t _L)	183°C 60-150 seconds	217°C 60-150 seconds
Peak	Temperature (T _p) Time (t _p)	235°C 10-30 seconds	260°C 20-40 seconds
Ramp-Down	Rate	6°C/second (max)	6°C/second (max)
Time from 25°C to peak Temperature		6 minutes max	8 minutes max

Temperature profile - (green area) for the assembly process in reflow ovens

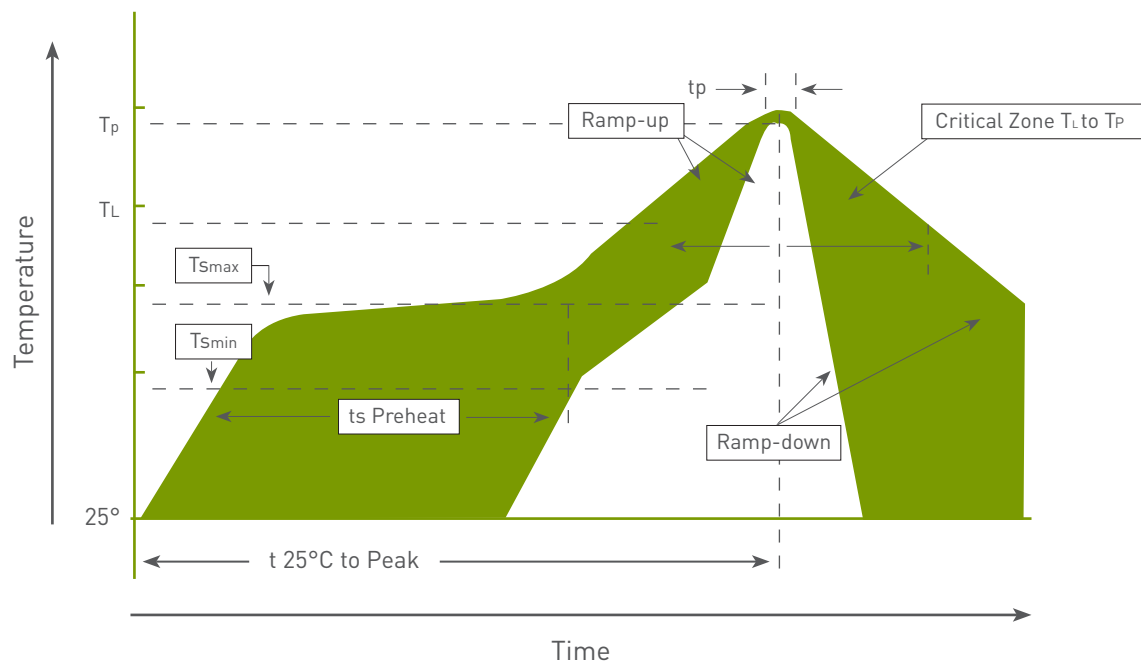

Figure 18. Temperature profile for the assembly process in reflow ovens

11. Packaging

450 Pieces per reel

Shrink line PE bag no push antenna and neat

Each one PE bags quantity not deficient

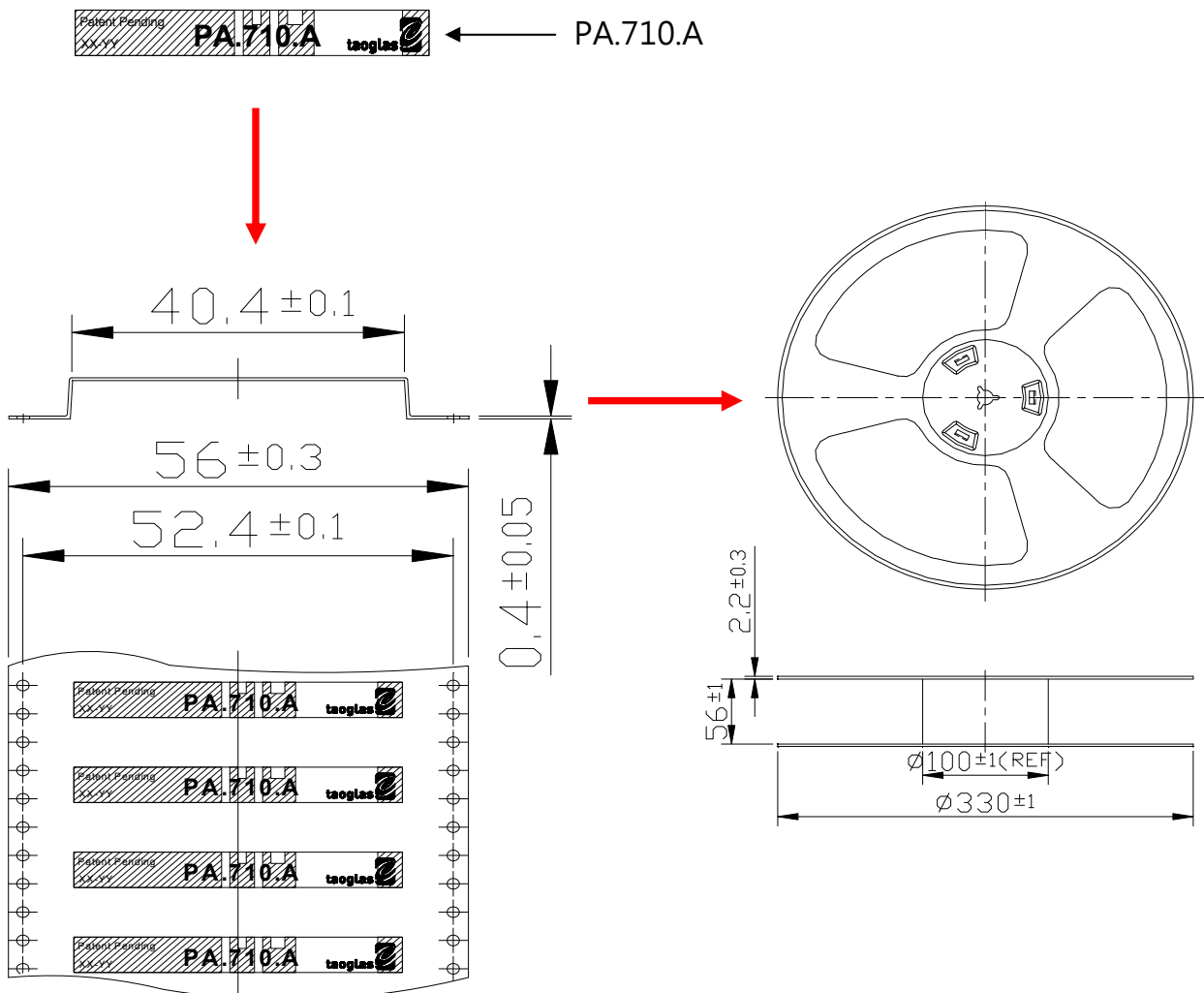

Taoglas makes no warranties based on the accuracy or completeness of the contents of this document and reserves the right to make changes to specifications and

product descriptions at any time without notice. Taoglas reserves all rights to this document and the information contained herein.

Reproduction, use or disclosure to third parties without express permission is strictly prohibited.
Copyright © 2013, Taoglas Ltd.