



AP.10F.07.0039B

Specification

Part No.	AP.10F.07.0039B
Product Name	2 Stage 25dB 10mm Active Ceramic Patch Antenna 39mm 0.81 Micro Coax with IPEX MHFI (U.FL compatible) with Front End SAW Filter
Feature	Small form factor GPS active patch 10mm*10mm*4mm, Wide Voltage 1.8V~5.5V 25dB LNA High performance Ultra Low Power Consumption RoHS Compliant

1. Introduction

The AP.10F active GPS patch antenna is the smallest GPS high performance antenna currently available in the world. It uses an extremely sensitive high dielectric constant powder formulation and tight process control and patented circular polarized side stripe design the 10*10*4mm patch antenna. The front end SAW filter reduces the risks where there is a cellular

transmitter nearby of interference from out of band frequencies which can cause LNA burn-out, saturation, or radiated spurious emissions.

This product is suited to small form factor mobile devices such as GPS Smartphones, Personal Location, Medical devices, Telematic devices and Automotive navigation

and tracking. Custom gain, connector and cable versions are available.

Custom tuning is available for specific customer device environments and is dependent on a minimum order quantity and NRE in some cases.

Please contact sales@taoglas.com for details.

The AP.10E consists of 2 functional blocks – the LNA and also the patch antenna.

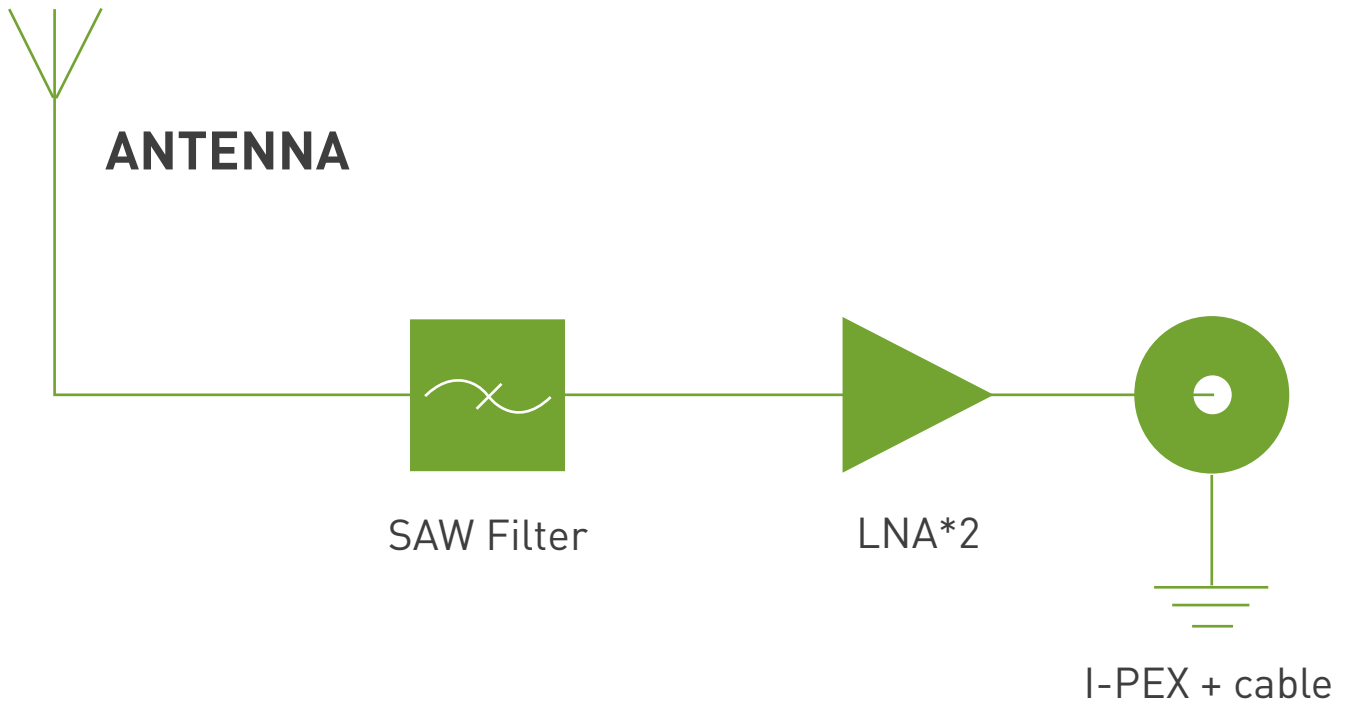

2. Specification

2.1 Patch Antenna

Parameter	Specification
Frequency	1575.42 ± 1.023MHz
Gain @ Zenith	-10dBic Typ. @ Zenith
Polarization	RHCP
Axial Ratio	4.0dB max @ Zenith
Patch Dimension	10*10*4.0mm

2.2 LNA

Parameter	Specification
Frequency	1575.42 ± 1.023MHz
Outer Band Attenuation	F0=1575.42MHz F0±30MHz 5dB min. F0±50MHz 20dB min. F0±100MHz 25dB min.
Output Impedance	50Ω
Output VSWR	2.0 Max
Pout at 1dB Gain	Typ. 11 dBm
Compression point	Min. 8 dBm

LNA Gain, Power Consumption and Noise Figure

Voltage	LNA Gain (Typ)	Power Consumption(mA) Typ	Noise Figure Typ
Min. 1.8V	20dB	5mA	2.7dB
Typ. 3.0V	25dB	10mA	2.5dB
Max. 5.5V	25dB	23mA	2.7dB

2.3 Cable* & Connector

Parameter	Specification
RF Cable	Coaxial Cable Ø 0.81 ± 0.1mm, length 39 ± 2.0mm
Connector	IPEX MHFI (U.FL)

3. LNA Gain and Out Band Rejection @3.0V

1 Active Ch/Trace 2 Response 3 Stimulus 4 Mkr/Analysis 5 Instr State

Tr1 S21 Log Mag 10.00dB/ Ref -40.00dB (F2)



Cg1	Tr1	S21	>1	1.5754200 GHz	26.079	dB
Cg1	Tr1	S21	2	1.6054200 GHz	-18.867	dB
Cg1	Tr1	S21	3	1.5454200 GHz	19.068	dB
Cg1	Tr1	S21	4	1.6254200 GHz	-25.753	dB
Cg1	Tr1	S21	5	1.5254200 GHz	0.8703	dB
Cg1	Tr1	S21	6	1.6754200 GHz	-15.542	dB
Cg1	Tr1	S21	7	1.4754200 GHz	-5.0099	dB

4. LNA Noise Figure @3.0V

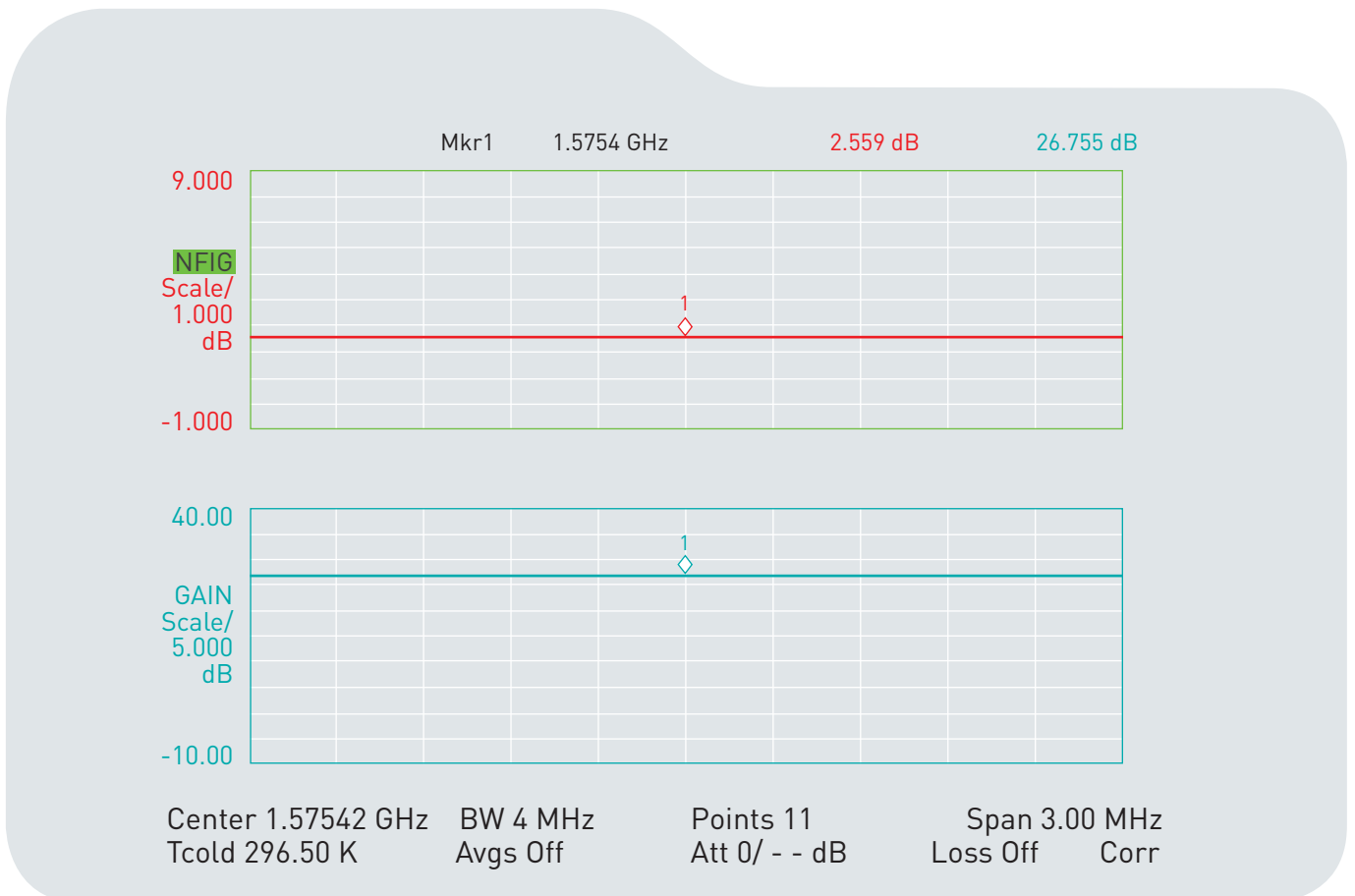

5. Total Specification (through Antenna, LNA, Cable and Connector)

Parameter	Specification
Frequency	1575.42 ± 1.023MHz
Gain	At 3V: 15 ± 4dBic @ 90°
Output Impedance	50Ω
Polarization	RHCP
Output VSWR	Max 2.0
Operation Temperature	-40°C to + 85°C
Storage Temperature	-40°C to + 85°C
Relative Humidity	40% to 95%
Input Voltage	Min. 1.8V, Typ. 3.0V, Max. 5.5V
Antenna	10*10*4mm

6. Radiation Patterns

6.1 XZ Plane Radiation

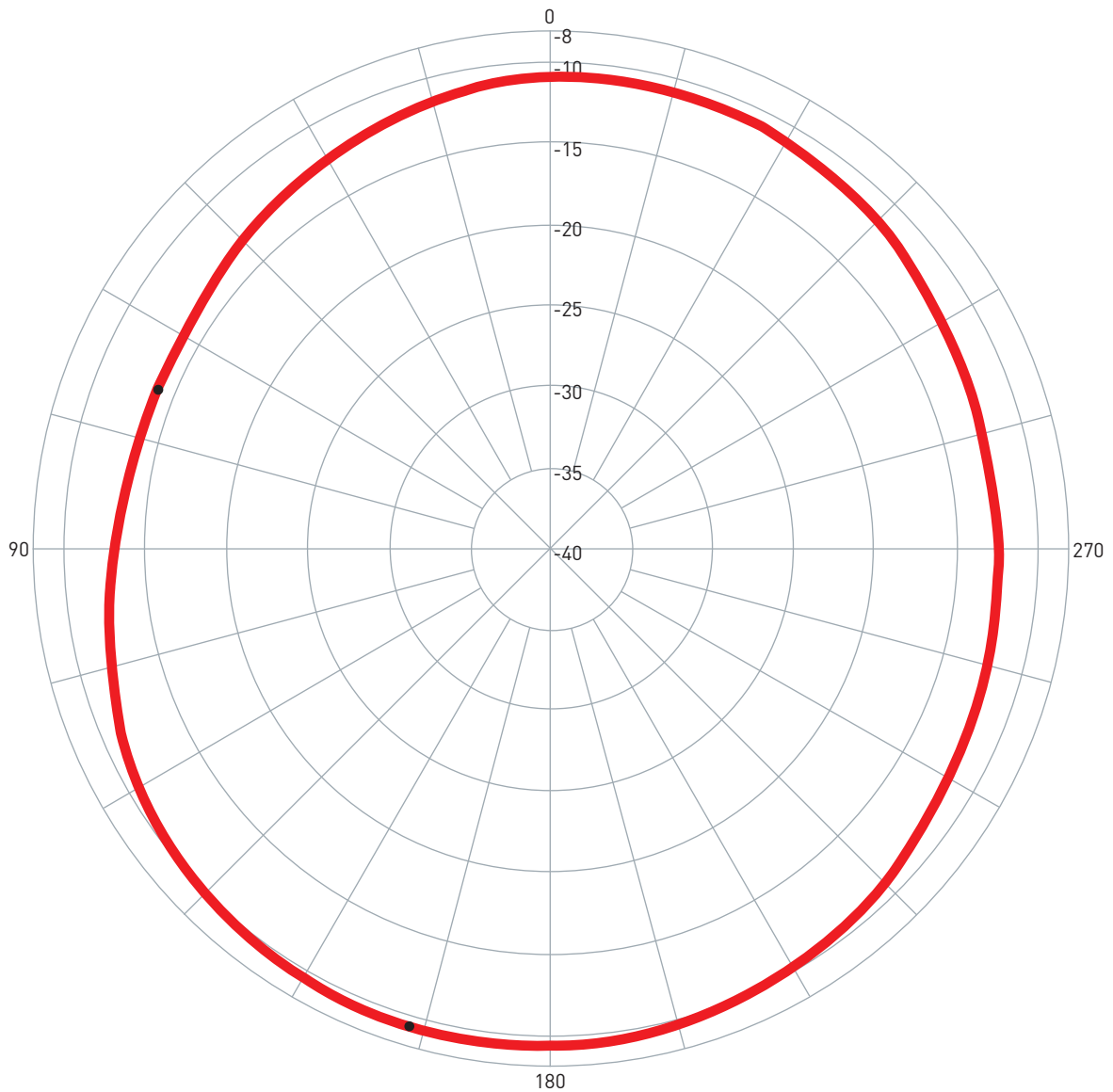

Pattern	Model No.	Test Mode	Freq (MHz)	Max Gain(dBi)	Min Gain(dBi)	Avg. Gain(dBi)	Source Polar.	Date
1	AP.10F.07.0039B	XZ	1624.00	-9.27 / 163.26	-13.80 / 68.02	-11.23	RHCP	2010/4/29

6.2 YZ Plane Radiation

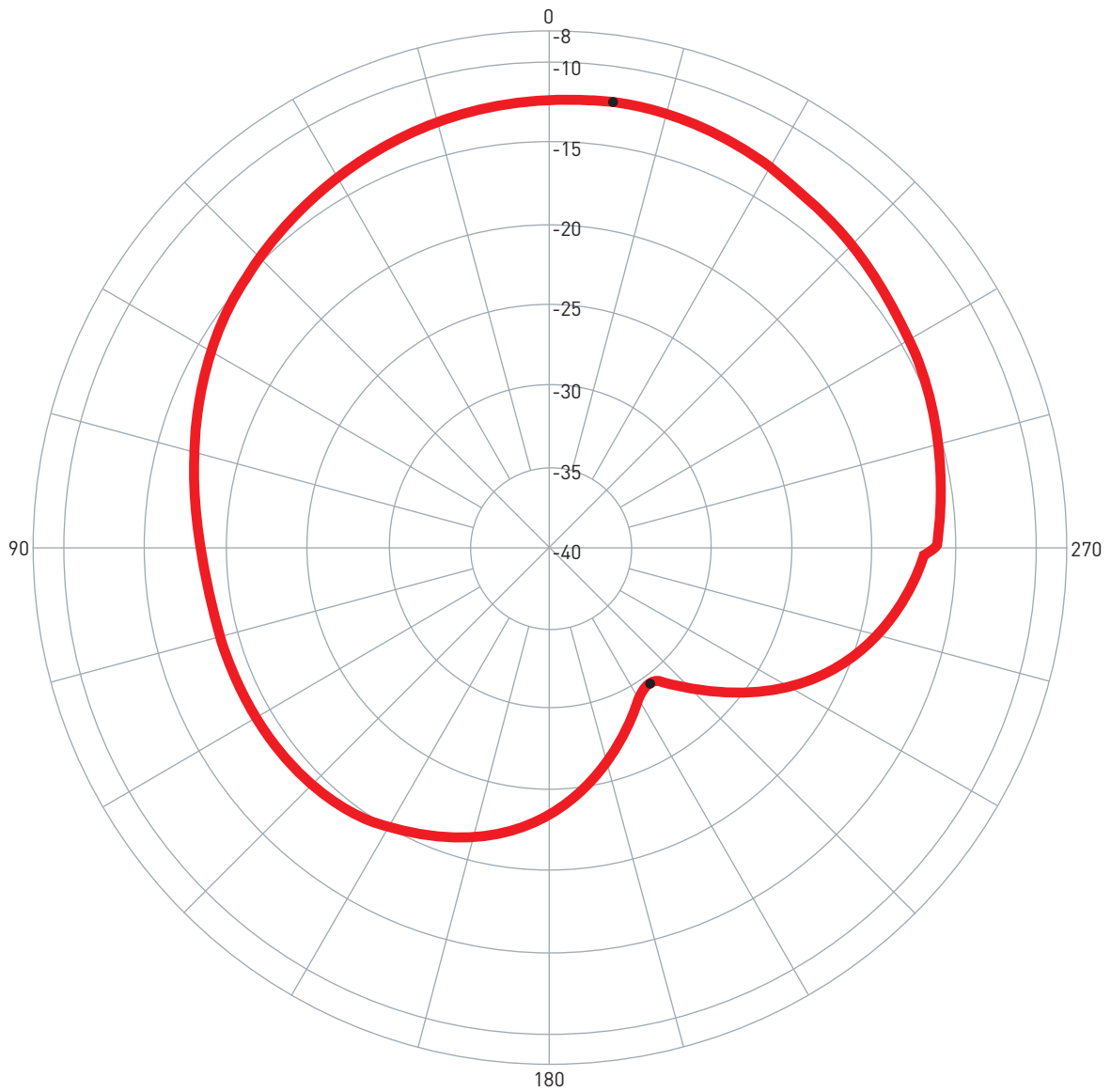

Pattern	Model No.	Test Mode	Freq (MHz)	Max Gain(dBi)	Min Gain(dBi)	Avg. Gain(dBi)	Source Polar.	Date
1	AP.10F.07.0039B	YZ	1624.00	-12.30 / 352.00	-29.55 / 216.00	-16.23	RHCP	2010/4/29

6.3 XY Plane Radiation

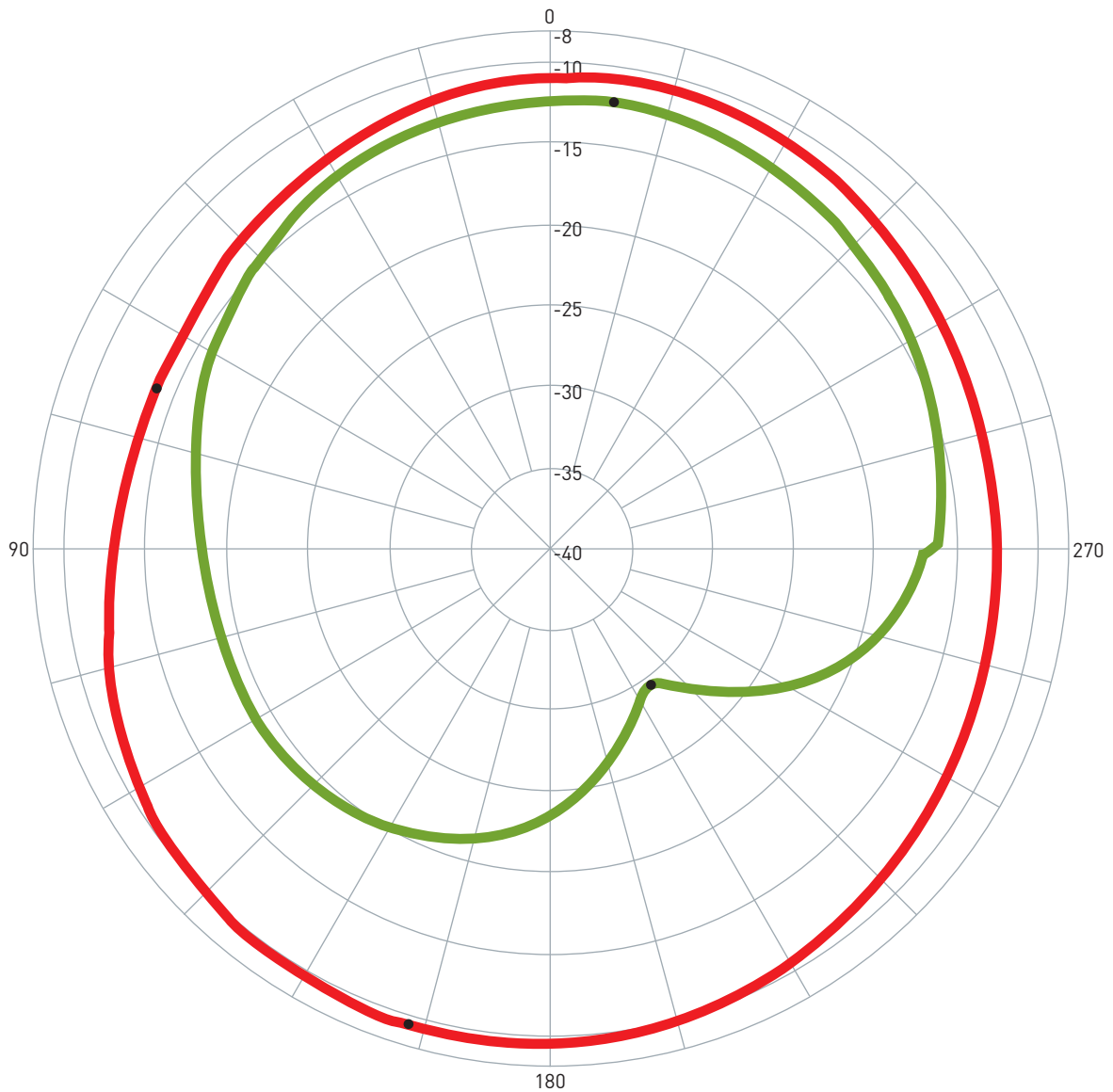

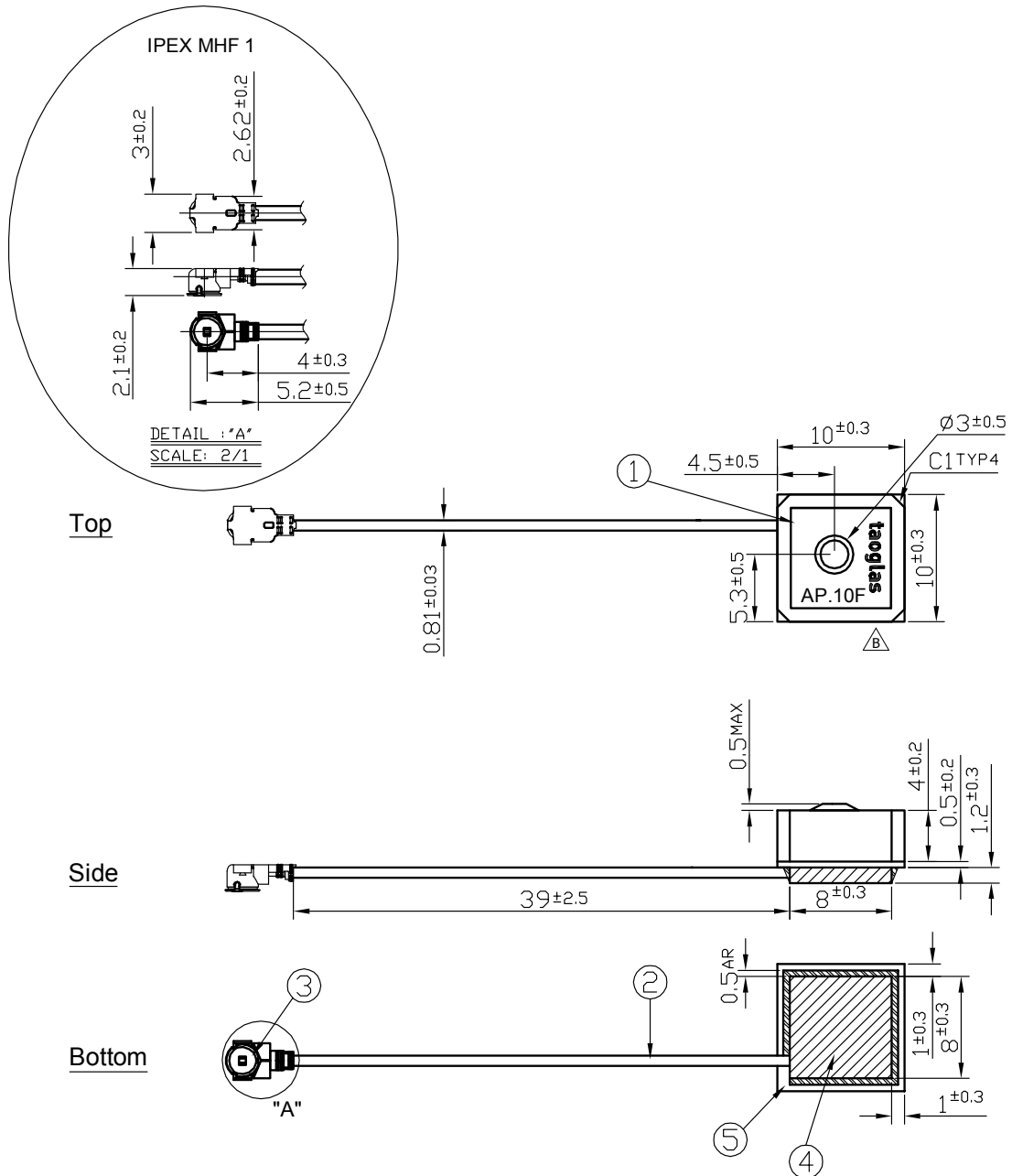

Pattern	Model No.	Test Mode	Freq (MHz)	Max Gain(dBi)	Min Gain(dBi)	Avg. Gain(dBi)	Source Polar.	Date
1	AP.10F.07.0039B	XZ	1624.00	-9.27 / 163.26	-13.80 / 68.02	-11.23	RHCP	2010/4/29
2	AP.10F.07.0039B	YZ	1624.00	-12.30 / 352.00	-29.55 / 216.00	-16.23	RHCP	2010/4/29

7. Antenna Drawing



Name	P/N	Material	Finish	QTY
1 AP.10F Patch (10*10*4mm)	AP.10F	Ceramic	Clear	1
2 0.81 Coaxial Cable	OD.081.CM	FEP	Gray	1
3 IPEX MHF1	IPEX.MHFI.113	Brass	Gold	1
4 Shielding Case		Tin (SPTE)	Tin Plated	1
5 PCB		FR4 0.5t	Green	1

NOTE:

1. Soldered area 
2. Shielding case area 
3. All material must be RoHS compliant.
4. The connector orientation has a fixed position to the antenna as per drawing.

8. Plugs Usage Precautions

8.1 Mating / unmating

(1) To disconnect connectors, insert the end portion of I-PEX under the connector flanges and pull off vertically, in the direction of the connector mating axis.

(2) To mate the connectors, the mating axes of both connectors must be aligned and the connectors can be mated. The "click" will confirm fully mated connection.

Do not attempt to insert on an extreme angle.

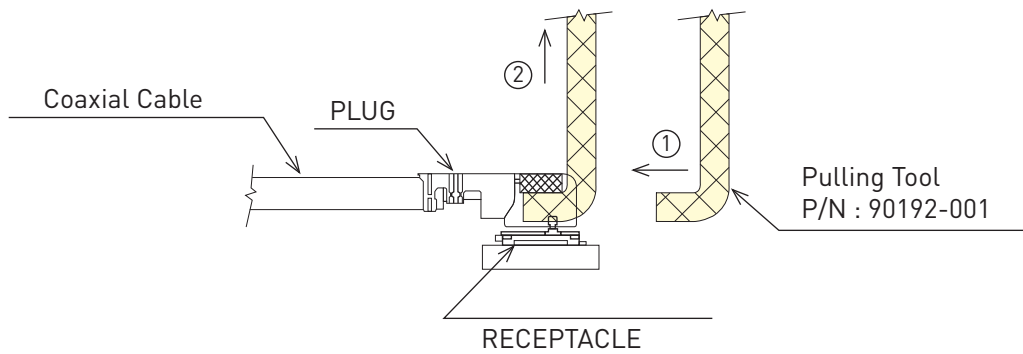

8.2 Pull forces on the cable after connectors are mated

After the connectors are mated, do not apply a load to the cable in excess of the values indicated in the diagram below.

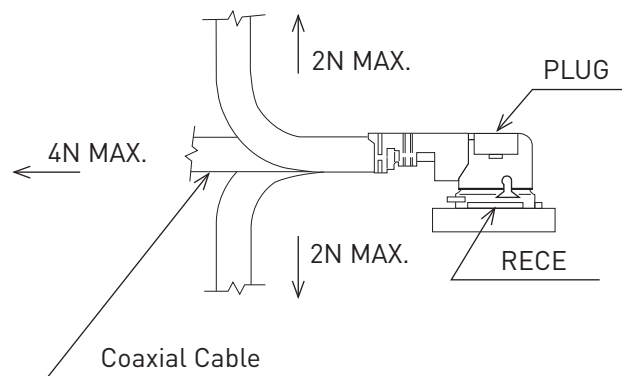

9. Packaging

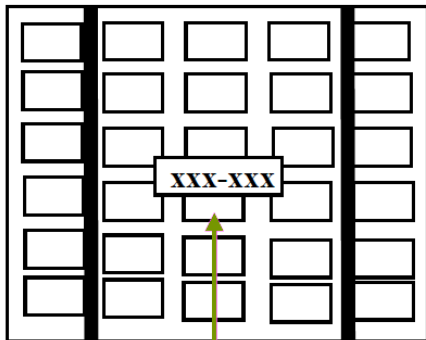

- *Packaged in Tray with Foam
- *One Tray = 60 pieces
- *6 Trays per Section = 360 pcs

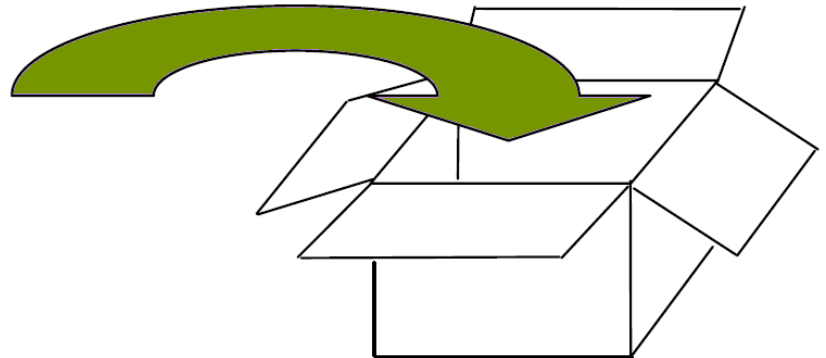

- *Each Carton contains 3 Sections
- *1080 pieces per Carton

Taoglas makes no warranties based on the accuracy or completeness of the contents of this document and reserves the right to make changes to specifications and

product descriptions at any time without notice.

Taoglas reserves all rights to this document and the information

contained herein. Reproduction, use or disclosure to third parties without express permission is strictly prohibited. Copyright © 2012, Taoglas Ltd.