



AP.12B.07.0046A

Specification

Part No.	AP.12B.07.0046A
Product Name	12mm Two Stage Active GPS Patch Antenna
Feature	<ul style="list-style-type: none"> Ultra Miniature GPS active patch High performance Ultra low power consumption RoHS compliant

1. Introduction

This miniaturised GPS Active Antenna module combines a tiny 12mm squared ceramic patch antenna from Cirocomm with a two stage low noise amplifier. It is available as a 'plug and play' format for onboard integration with GPS receiver

modules via ultra thin coaxial cable and connector from IPEX.

Only 5.5mm in height, this new Taoglas active antenna module utilises XtremeGain™ technology for the

highest industry sensitivity.

Designed for use with the new generation of GPS receiver modules using chipsets from SiRF, Ublox, Nemerix, Fastrax, Navsync, Falcom, Telit, Tyco, Siemens etc.

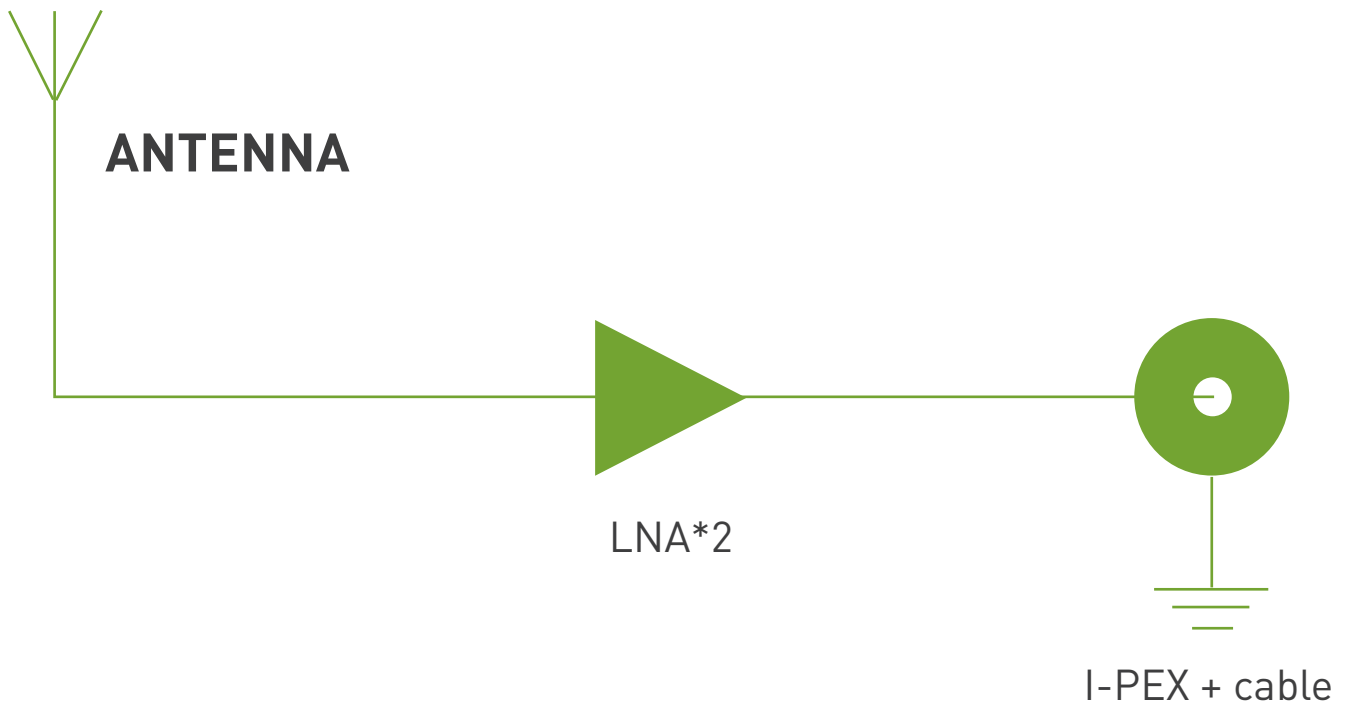

2. Specification

2.1 Patch Antenna

Parameter	Specification
Frequency	1575.42 ± 1.023MHz
Antenna Gain	Typ 1.5 dBic @ Zenith(13.4mm*13.4mm Ground Plane)
Impedance	50Ω
Polarization	RHCP
Axial Ratio	Max 4.0dB @ Zenith
Patch Dimension	12mm x 12mm x 3.5mm

2.2 LNA

Parameter	Specification
Frequency	1575.42 ± 1.023MHz
Output Impedance	50Ω
Output VSWR	2.0 Max
Pout at 1dB Gain	+5dBm Typ.
Compression point	

LNA Gain, Power Consumption and Noise Figure

Voltage	LNA Gain (Typ)	Power Consumption(mA) Typ	Noise Figure Typ
Min. 1.8V	9dB	2.5mA	4.5dB
Typ. 3.0V	25dB	10mA	1.6dB
Max. 5.5V	28dB	22mA	1.6dB

2.3 Cable* & Connector

Parameter	Specification
RF Cable	Coaxial Cable Ø 1.13 ± 0.1mm, length 46 ± 2.5mm
Connector	IPEX MHFI (U.FL)

3. LNA Gain and Out Band Rejection @3.0V

1 Active Ch/Trace 2 Response 3 Stimulus 4 Mkr/Analysis 5 Instr State

▶ Tr1 S21 Log Mag 10.00dB/ Ref -40.00dB (F2)

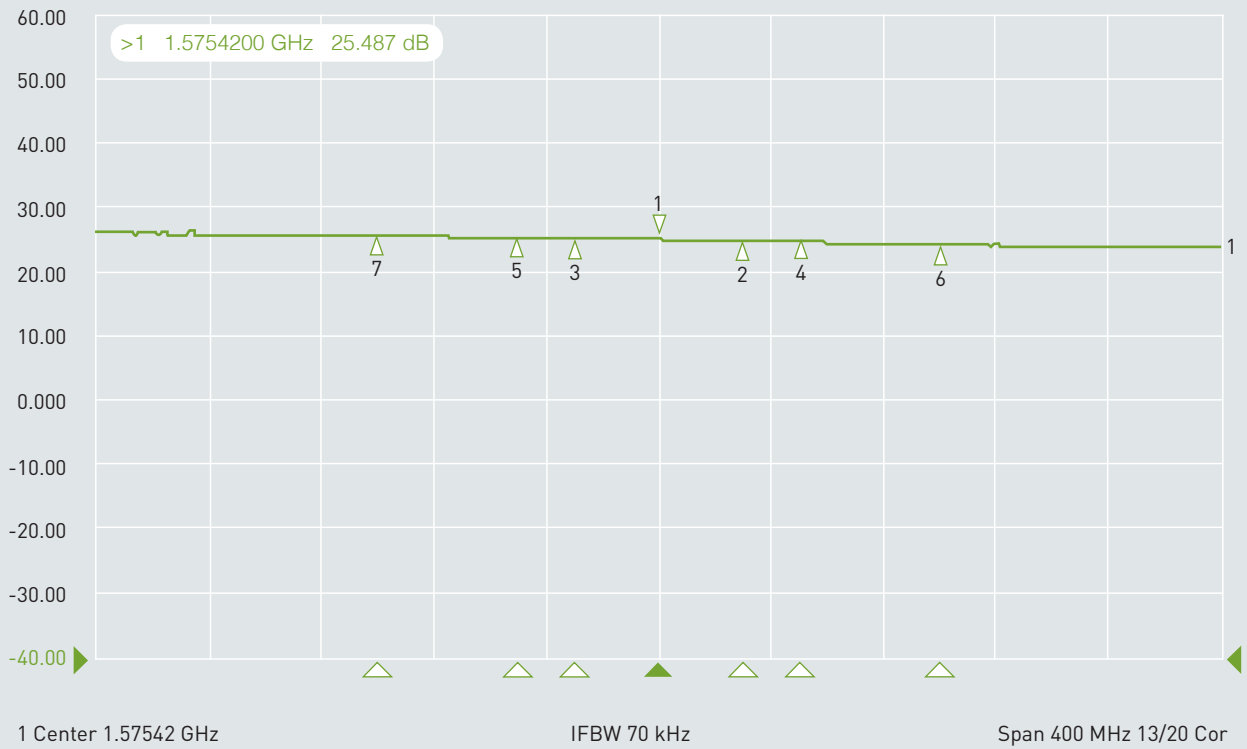

Cg1	Tr1	S21	>1	1.5754200 GHz	25.487	dB
Cg1	Tr1	S21	2	1.6054200 GHz	25.290	dB
Cg1	Tr1	S21	3	1.5454200 GHz	25.698	dB
Cg1	Tr1	S21	4	1.6254200 GHz	25.144	dB
Cg1	Tr1	S21	5	1.5254200 GHz	25.765	dB
Cg1	Tr1	S21	6	1.6754200 GHz	24.765	dB
Cg1	Tr1	S21	7	1.4754200 GHz	26.085	dB

4. LNA Noise Figure @3.0V

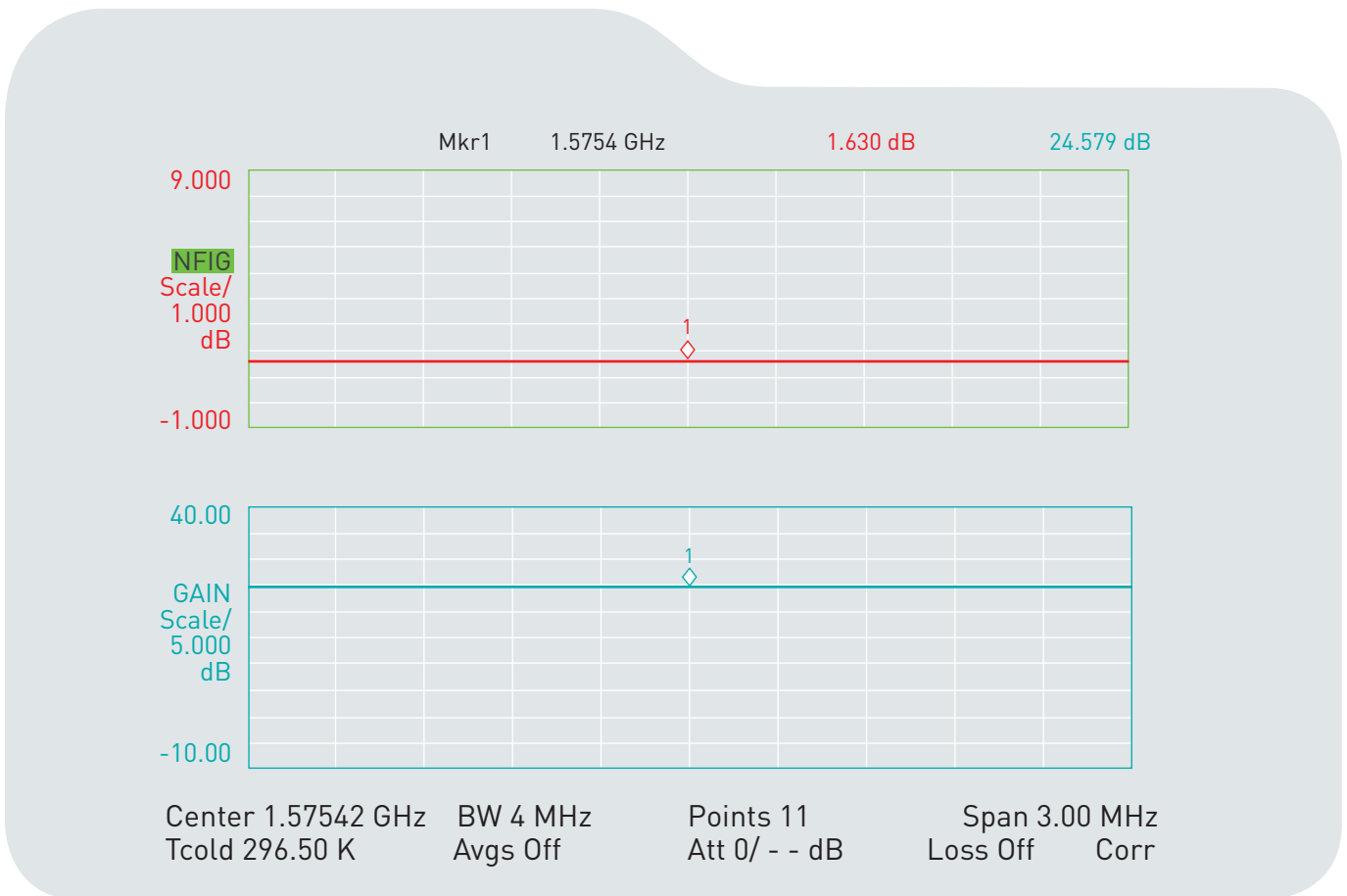

5. Total Specification (through Antenna, LNA, Cable and Connector)

Parameter	Specification
Frequency	1575.42 ± 1.023MHz
Gain@3V	23.5 ± 4dBic @ 90°
Output Impedance	50Ω
Polarization	RHCP
Output VSWR	Max 2.0
Operation Temperature	-40°C to + 85°C
Storage Temperature	-40°C to + 85°C
Relative Humidity	40% to 95%
Input Voltage	Min. 1.8V, Typ. 3.0V, Max. 5.5V

6. Radiation Patterns

XZ-Plane

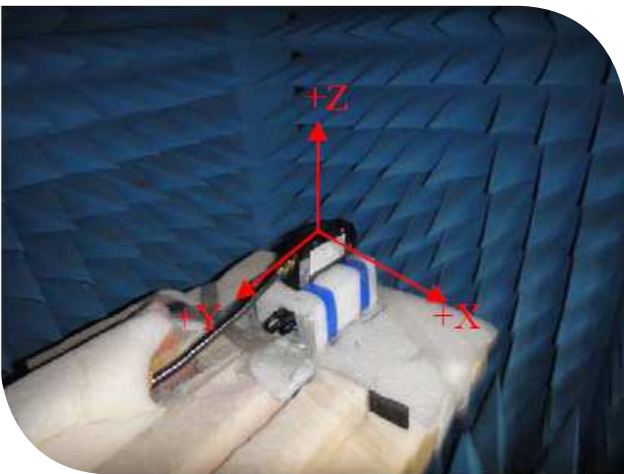

YZ-Plane

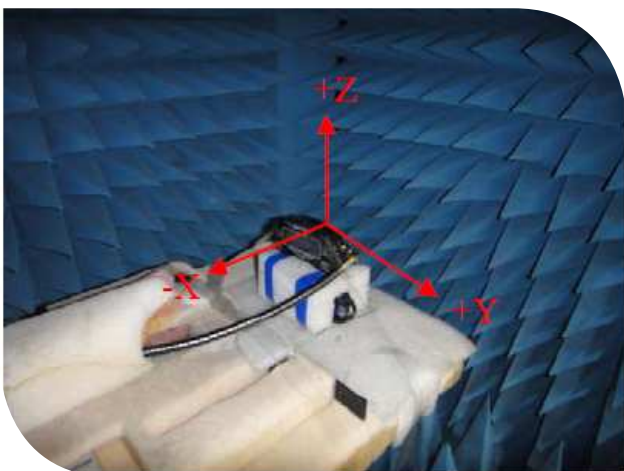

6.1 XZ Plane Radiation

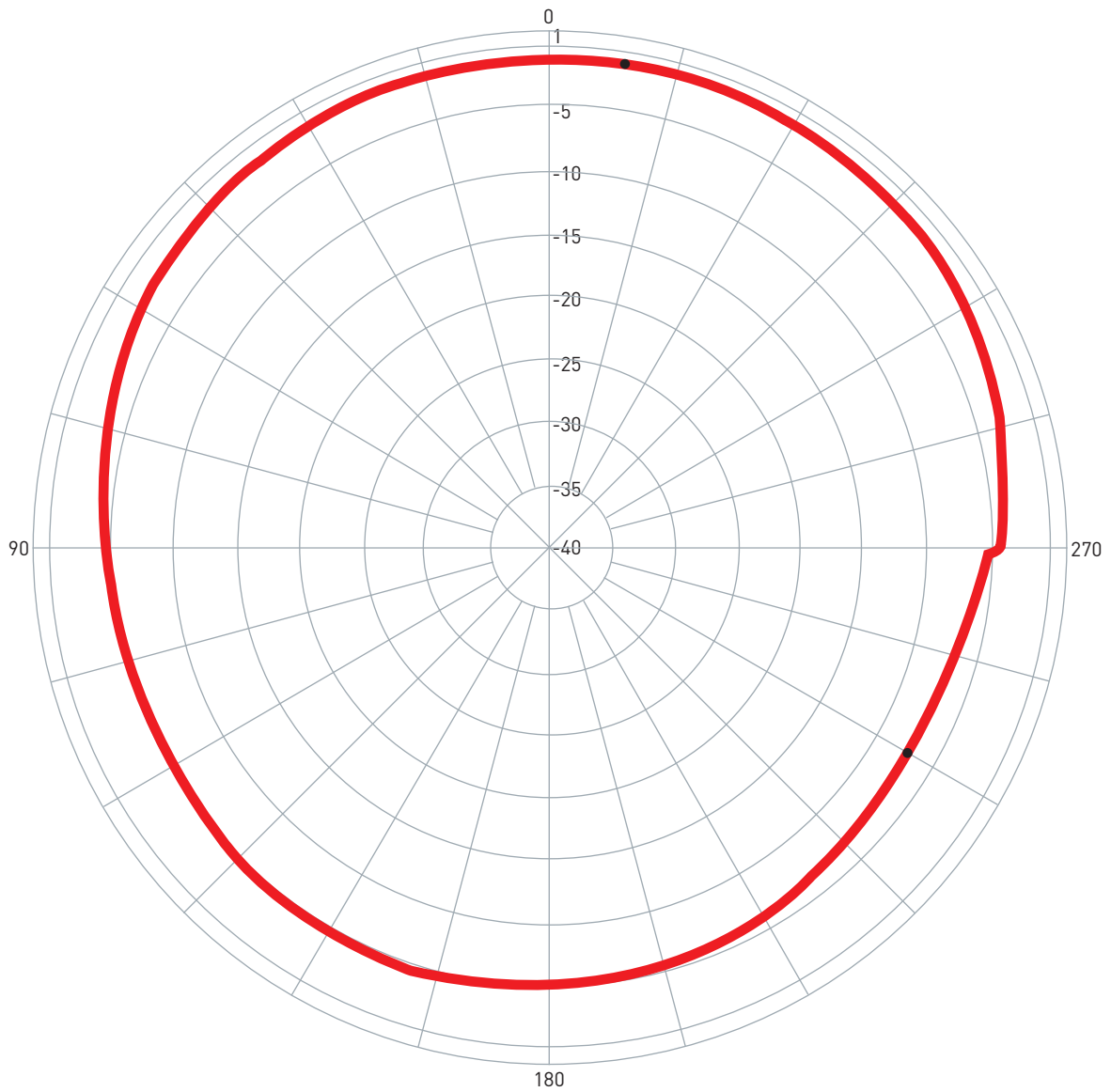

Pattern	Model No.	Test Mode	Freq (MHz)	Max Gain(dBi)	Min Gain(dBi)	Avg. Gain(dBi)	Source Polar.	Date
1 ■	AP.12B.07.0046A	XZ	1575.42	-1.22 / 351.00	-7.31 / 240.00	-3.42	RHCP	2011/7/21

6.2 YZ Plane Radiation

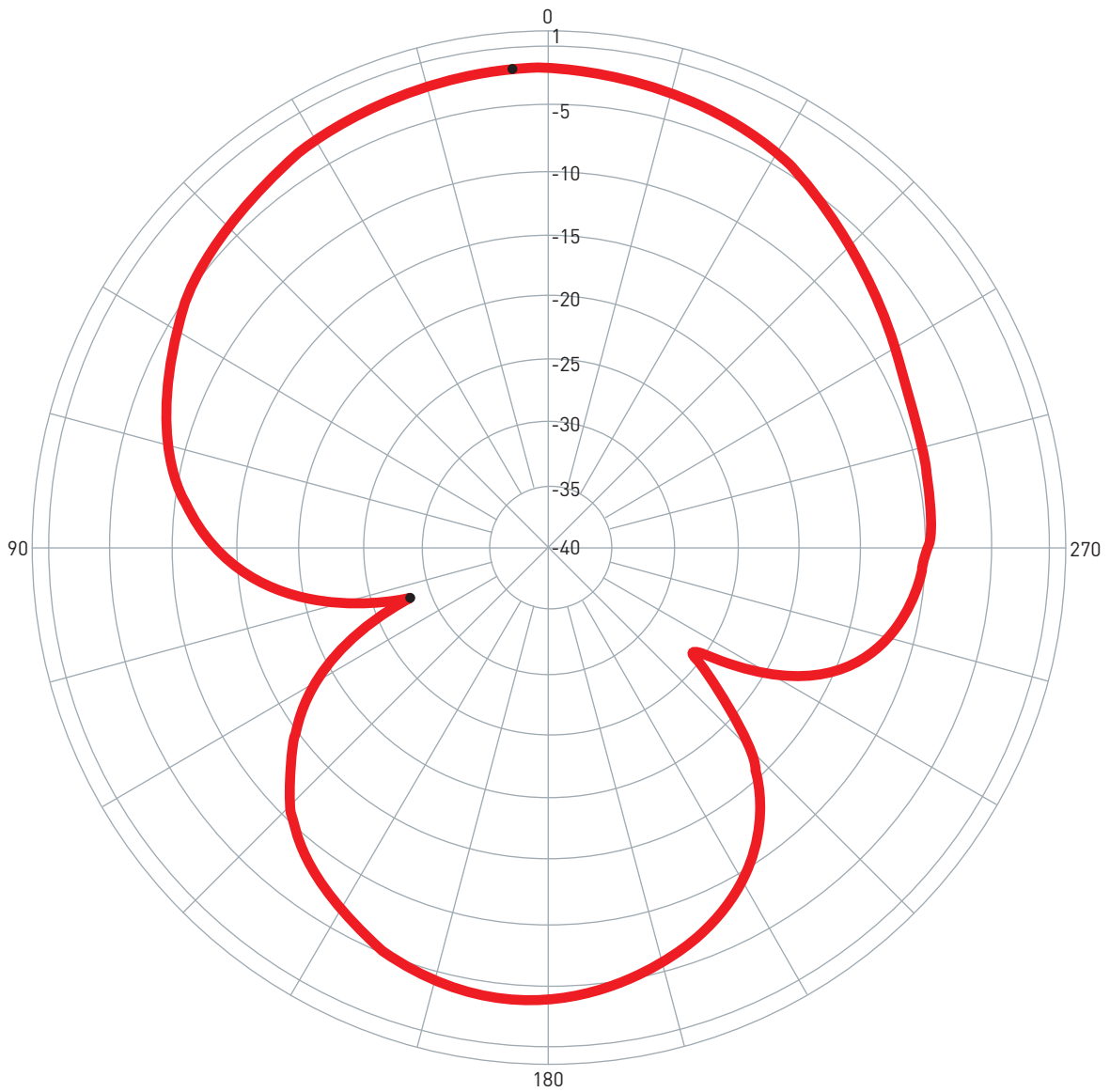

Pattern	Model No.	Test Mode	Freq (MHz)	Max Gain(dBi)	Min Gain(dBi)	Avg. Gain(dBi)	Source Polar.	Date
1	AP.12B.07.0046A	YZ	1575.42	-1.85 / 4.00	-28.22 / 110.00	-6.12	RHCP	2011/7/21

6.3 XY Plane Radiation

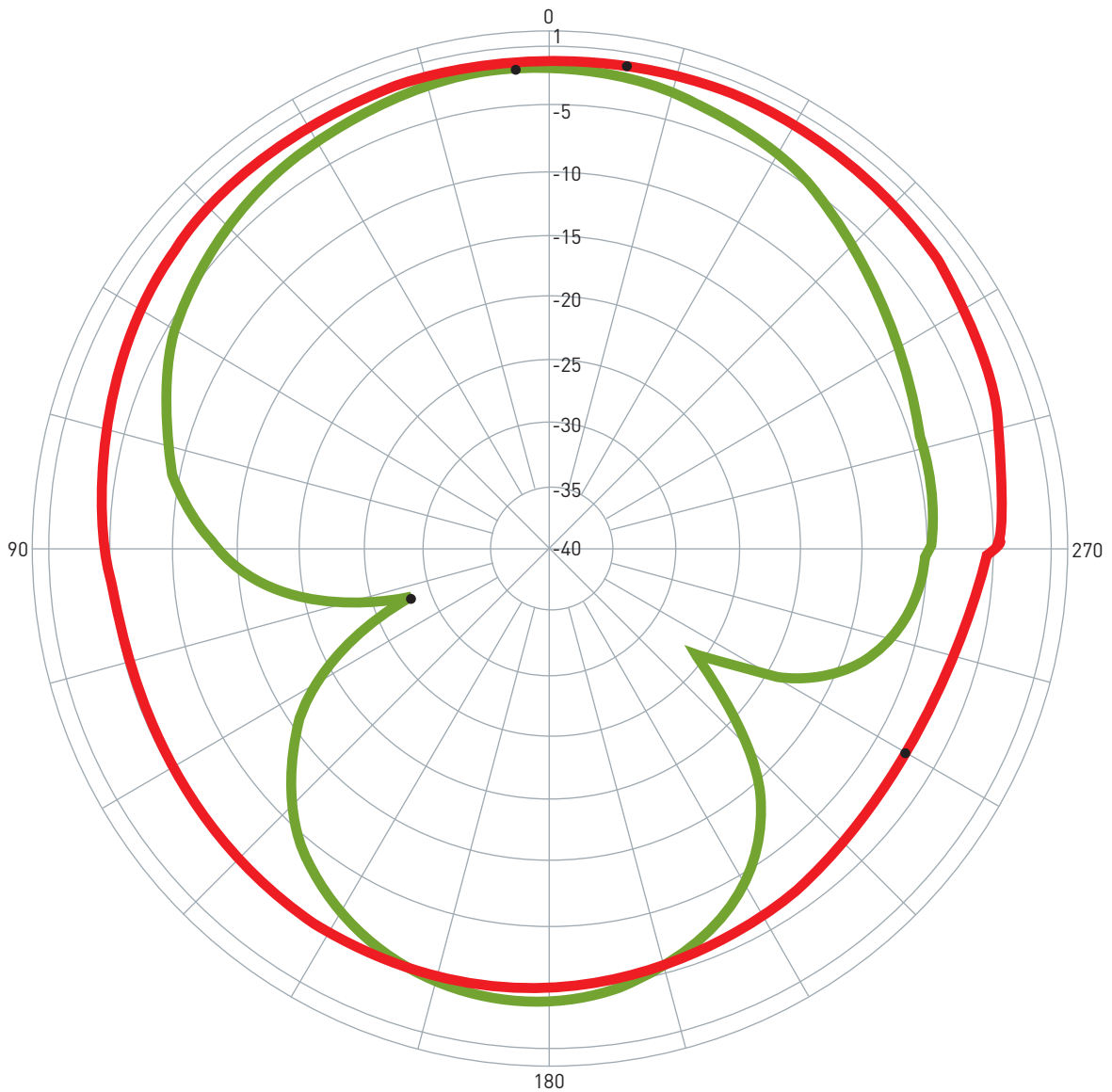

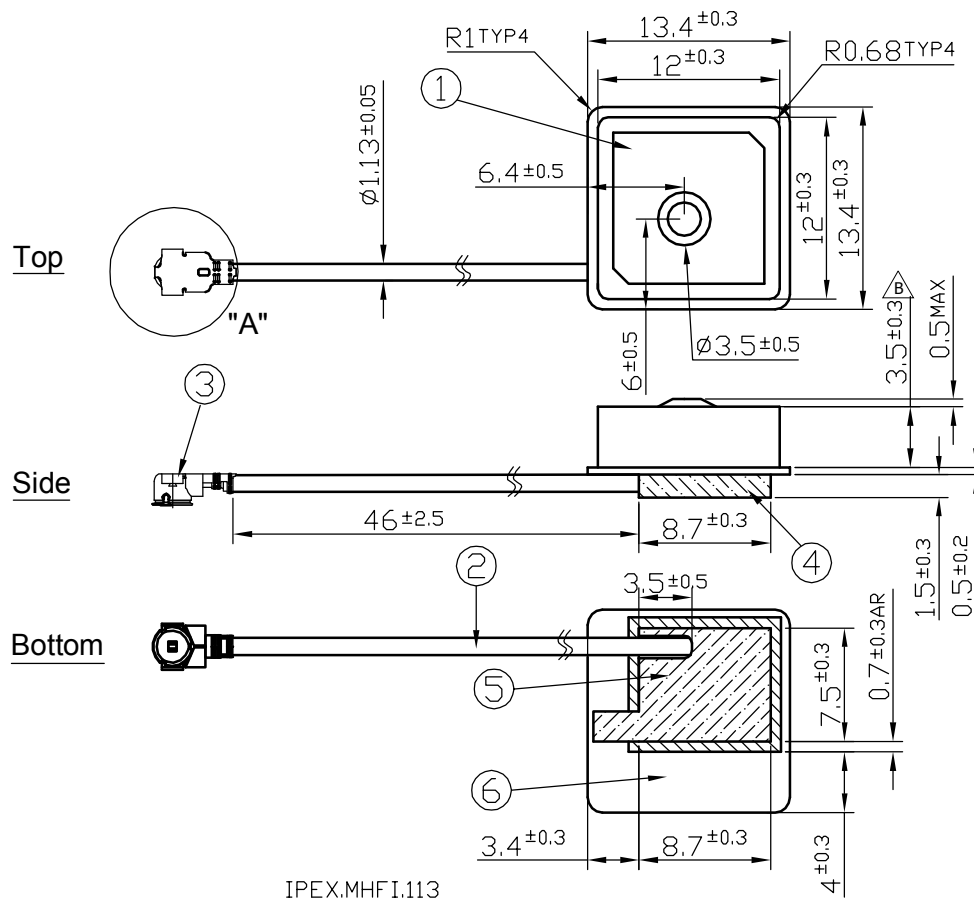

Pattern	Model No.	Test Mode	Freq (MHz)	Max Gain(dBi)	Min Gain(dBi)	Avg. Gain(dBi)	Source Polar.	Date
1	AP.12B.07.0046A	XZ	1575.42	-1.22 / 351.00	-7.31 / 240.00	-3.42	RHCP	2011/7/21
2	AP.12B.07.0046A	YZ	1575.42	-1.85 / 4.00	-28.22 / 110.00	-6.12	RHCP	2011/7/21

7. Technical Drawing



NOTE:

1. Soldered area 
2. Shielding case area 
3. All material must be RoHS compliant.
4. The connector orientation has a fixed position to the antenna as per drawing.

	Name	P/N	Material	Finish	QTY
1	AP.12B Patch(12*12*4mm)	AP.12B	Ceramic	Clear	1
2	1.13 Coaxial Cable	OD.113.J	FEP	Gray	1
3	IPEX MHF1 Connector	IPEX.MHF1.113	Brass	Gold	1
4	Shielding Case		Tin (SPTE)	Tin Plated	1
5	Double Sided Adhesive		NITTO 5015	White Liner	1
6	AP.12B PCB		FR4 0.5t	Green	1

7.1 Connector Drawing

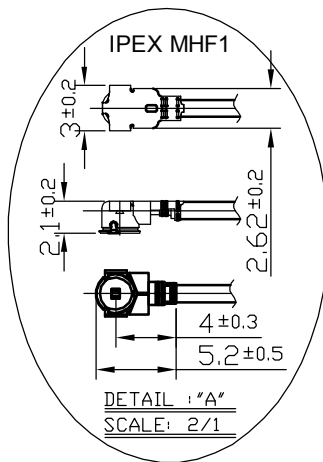

8. Plugs Usage Precautions

8.1 Mating / unmating

(1) To disconnect connectors, insert the end portion of I-PEX under the connector flanges and pull off vertically, in the direction of the connector mating axis.

(2) To mate the connectors, the mating axes of both connectors must be aligned and the connectors can be mated. The "click" will confirm fully mated connection.

Do not attempt to insert on an extreme angle.

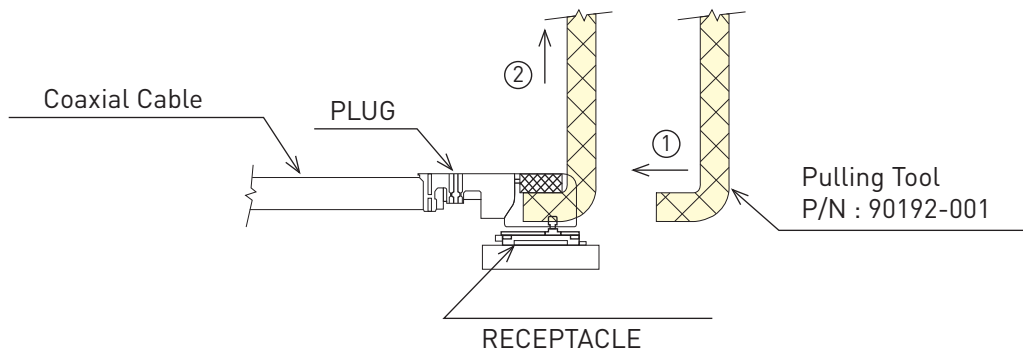

8.2 Pull forces on the cable after connectors are mated

After the connectors are mated, do not apply a load to the cable in excess of the values indicated in the diagram below.

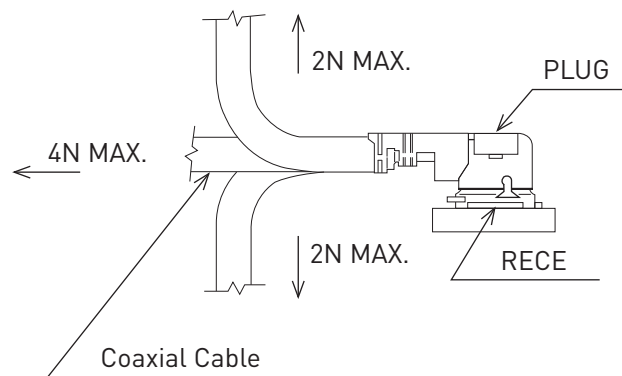

9. Packaging

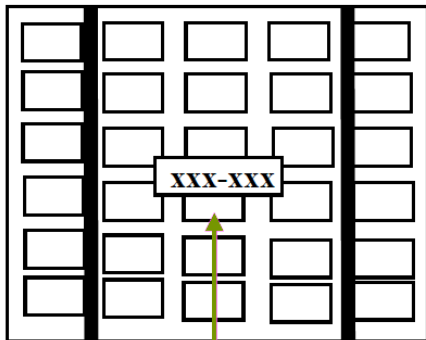

- *Packaged in Tray with Foam
- *One Tray = 60 pieces
- *6 Trays per Section = 360 pcs

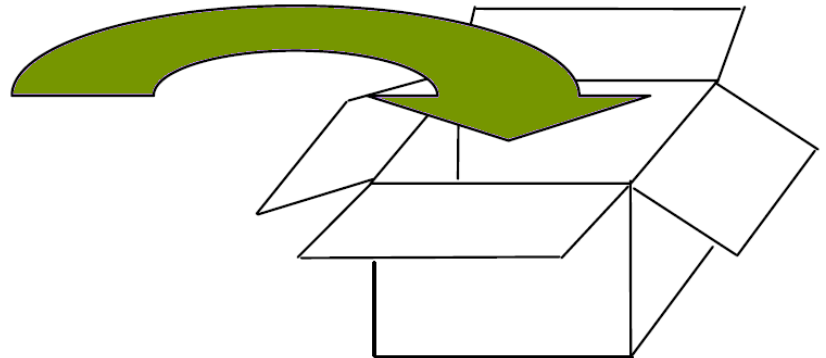

- *Each Carton contains 3 Sections
- *1080 pieces per Carton

Taoglas makes no warranties based on the accuracy or completeness of the contents of this document and reserves the right to make changes to specifications and

product descriptions at any time without notice.

Taoglas reserves all rights to this document and the information

contained herein. Reproduction, use or disclosure to third parties without express permission is strictly prohibited. Copyright © 2012, Taoglas Ltd.