

SPECIFICATION

Part No. : **CGGP.35.3.A.02**

Specification No : CGGP.35A

Product Name : 3.5mm thick GPS/Glonass Patch Antenna,
1575-1610MHz

Features : 35mm*35mm*3.5mm
ROHS Compliant

:



1. Key Antenna Performance Indicators

No	Parameter	Specification	Notes
1	Range of Receiving Frequency	GPS : 1575.42 ±1.023 MHz GLONASS : 1602±5MHz	
2	Center Frequency	1592MHz ± 6MHz	50*50mm GND Plane
3	Bandwidth	26MHz min	Return Loss @-10 dB
4	VSWR	1.5 max	Center Frequency
5	Gain at Zenith	+1.5 dBic typ.	
6	Polarization	RHCP	
7	Impedance	50 Ohms	
8	Frequency Temperature Coefficient (τ_f)	0 ± 20ppm / °C	-40°C to +85°C
9	Operating Temperature	-40°C to +85°C	

2. Mechanical Specifications

2.1 Shape and Dimension

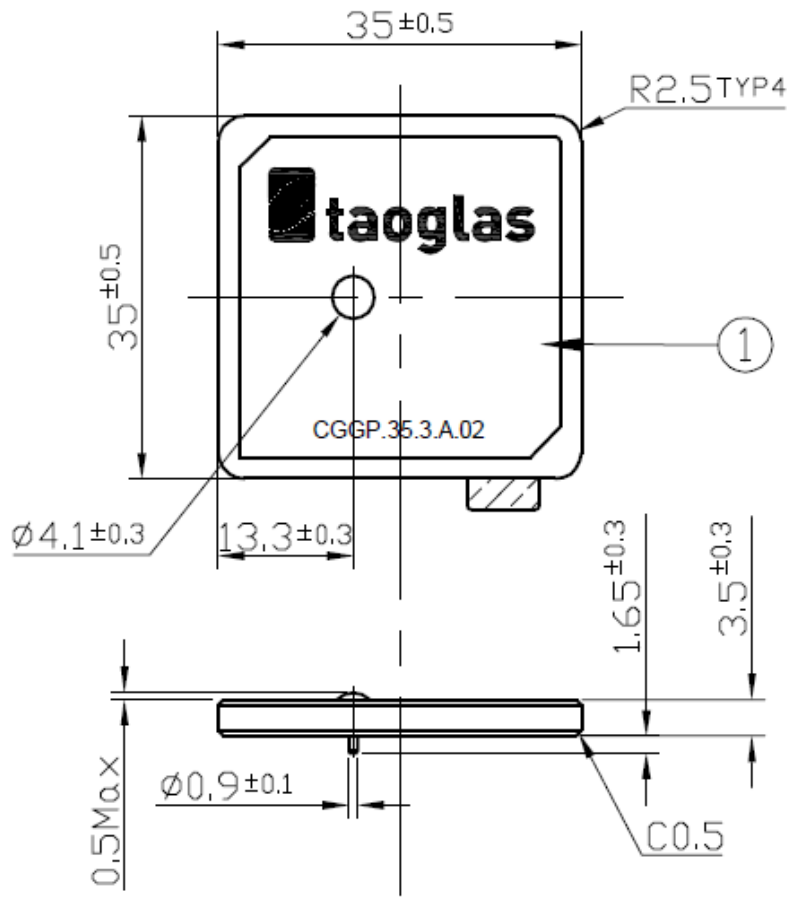

Top View

Side View

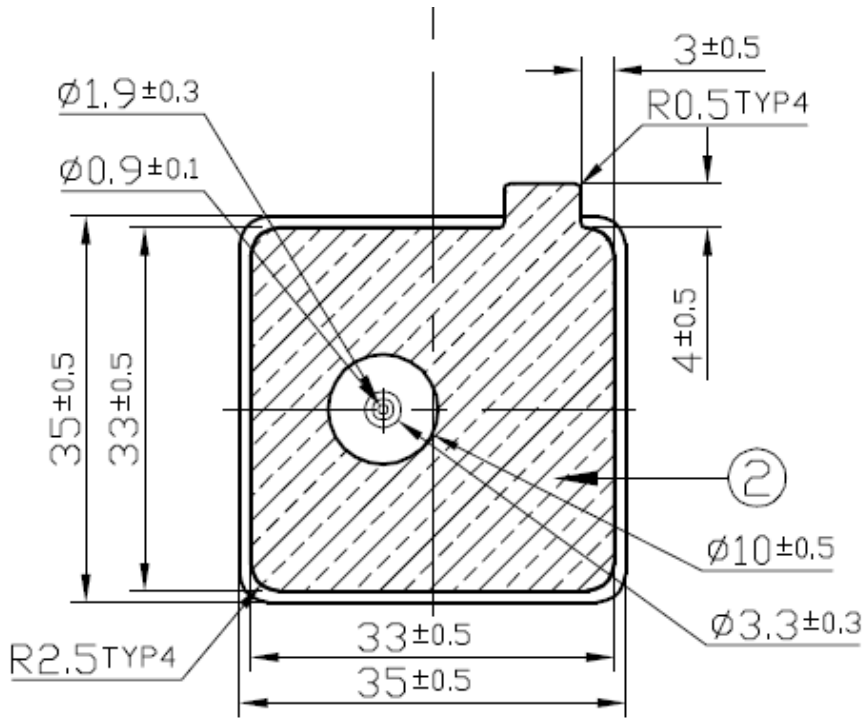

Bottom View

2.2 Layout

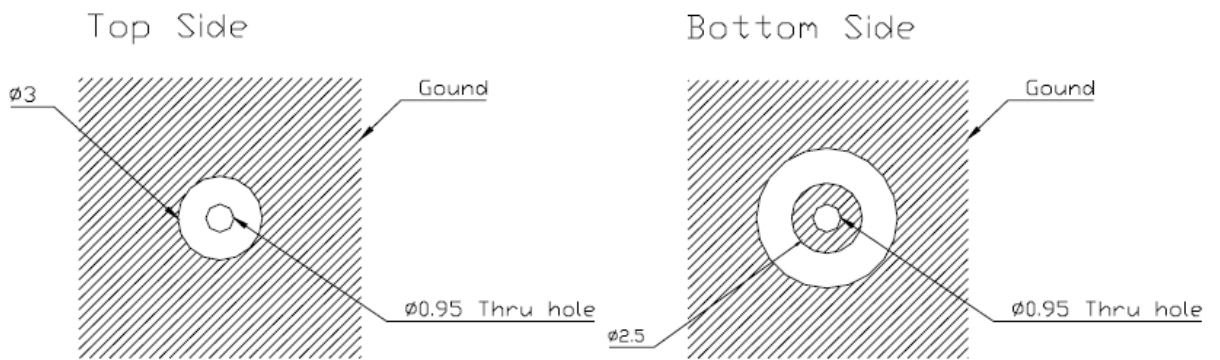

TOL: ± 0.20
UNIT: mm

3. Performance testing and results

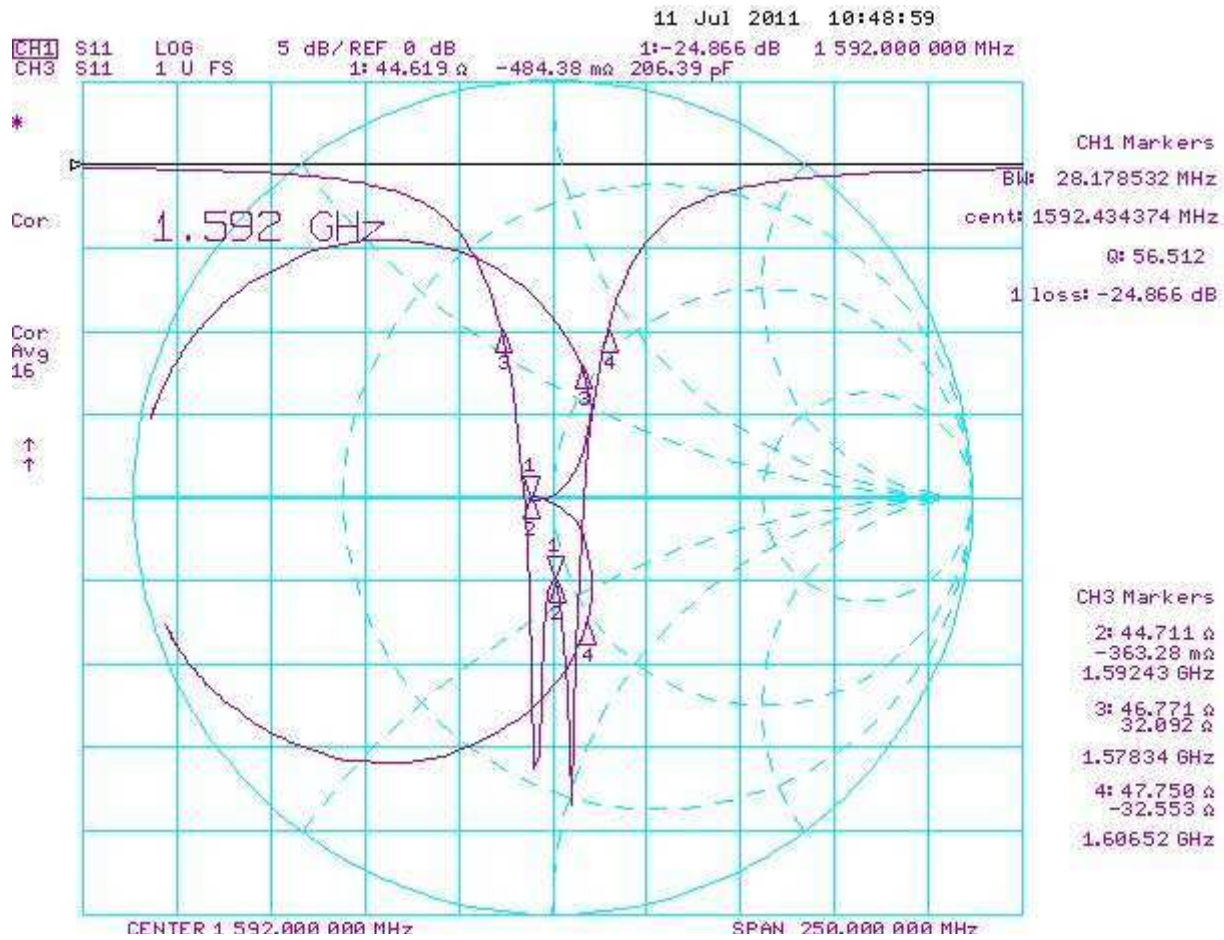

4. 2D Radiation Patterns

4.1 1575MHz - XZ-Plane

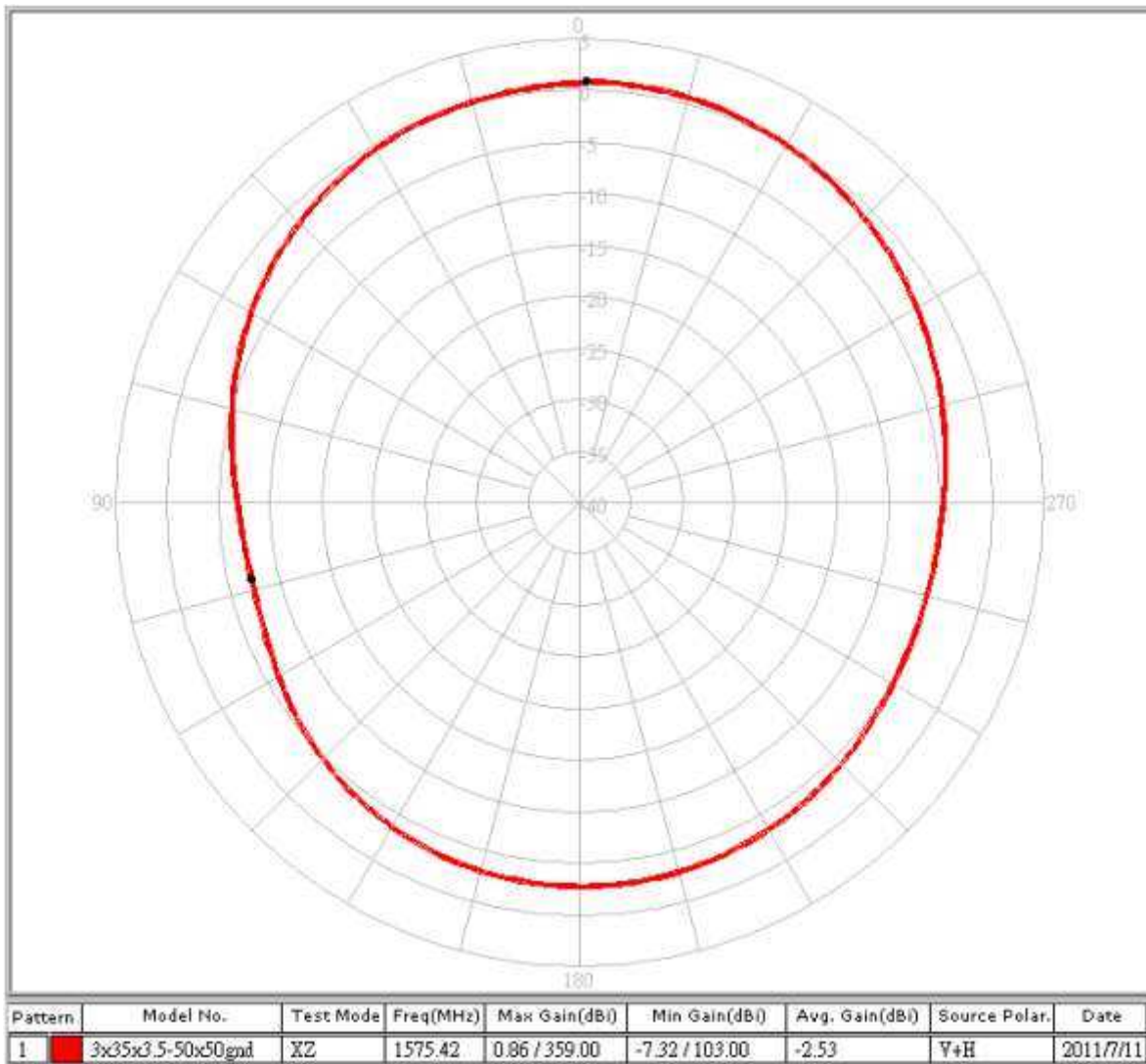

4.2 1575MHz - YZ-Plane

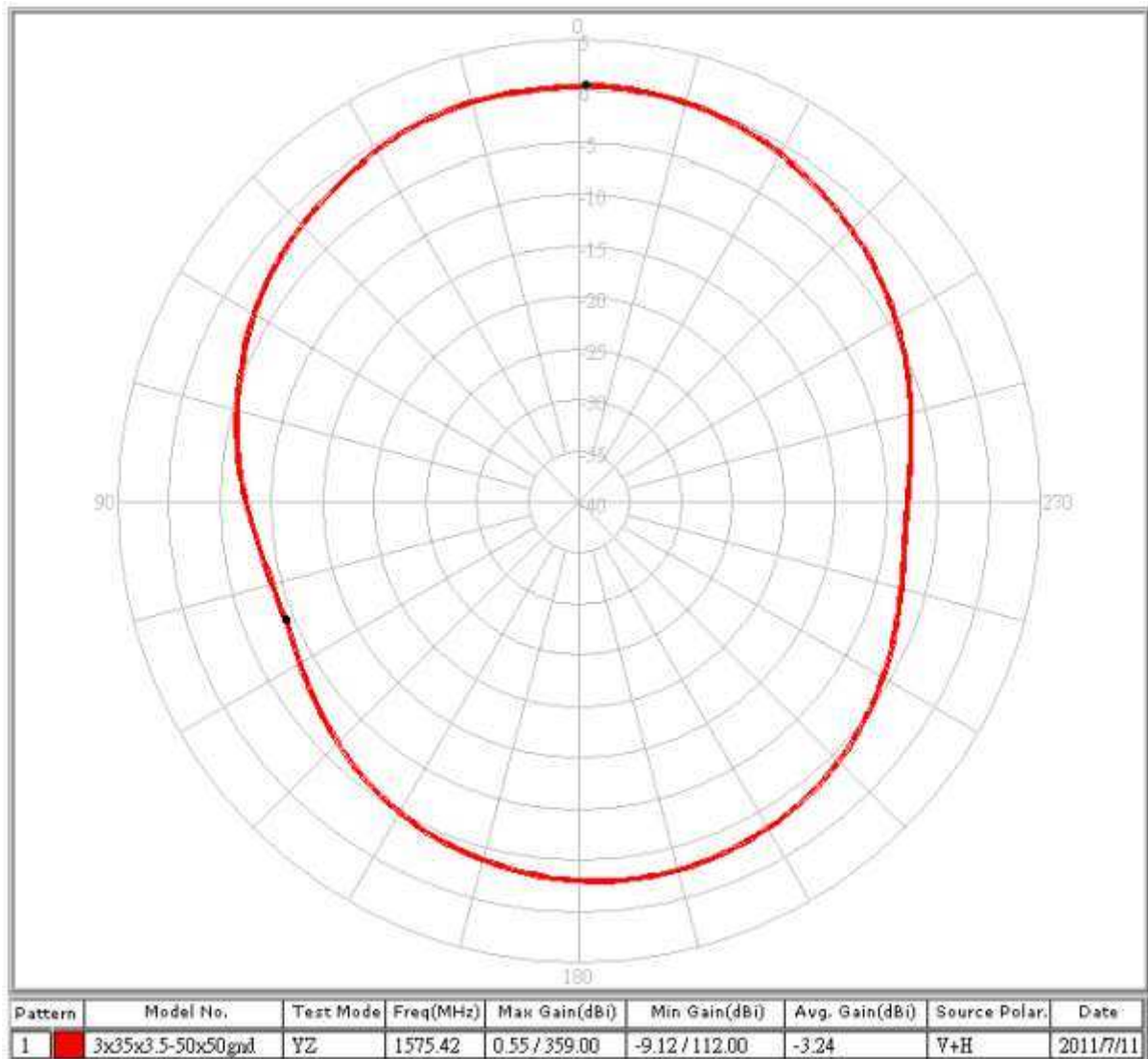

4.3 1602MHz - XZ-Plane

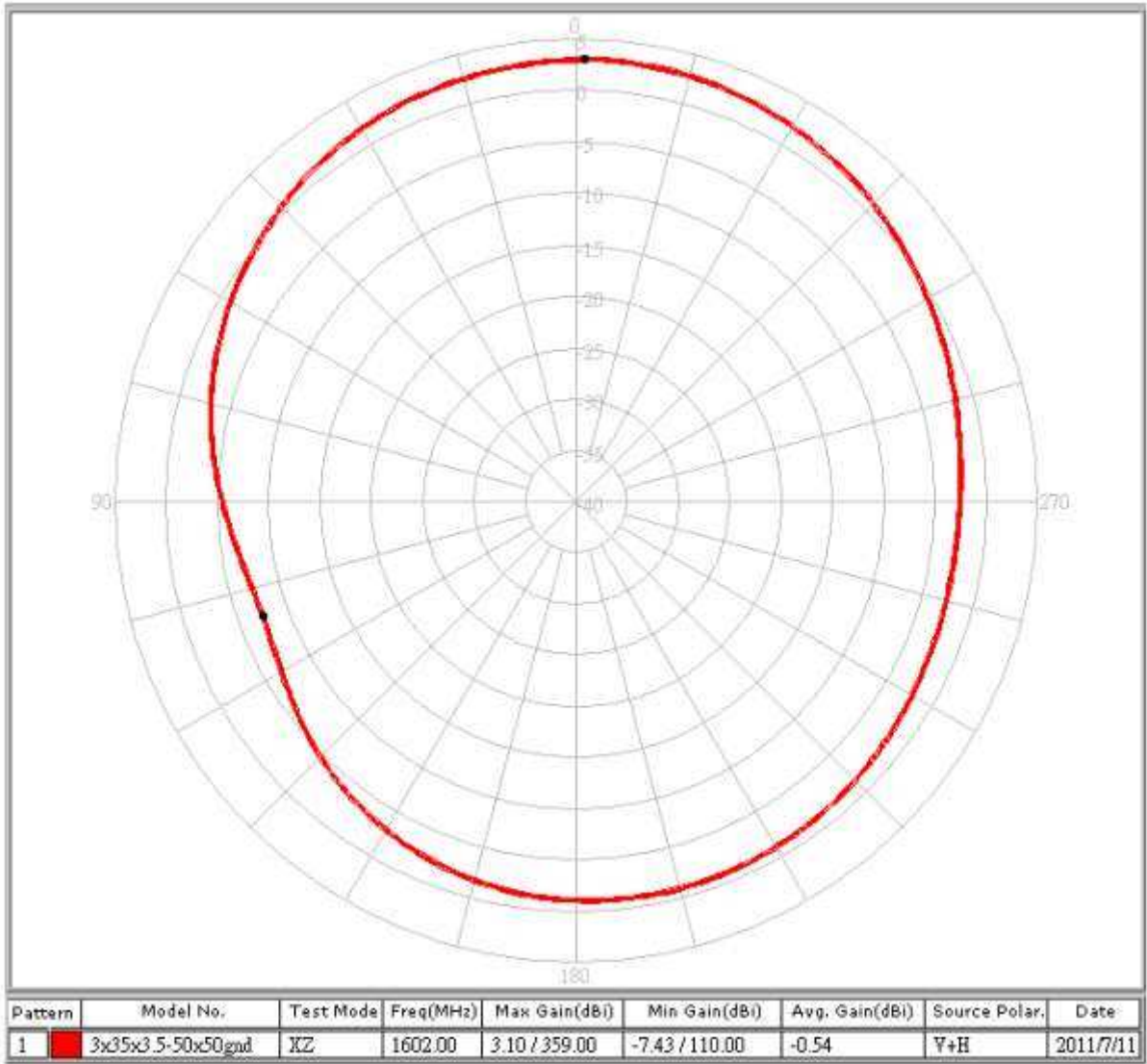

4.4 1602MHz - YZ-Plane

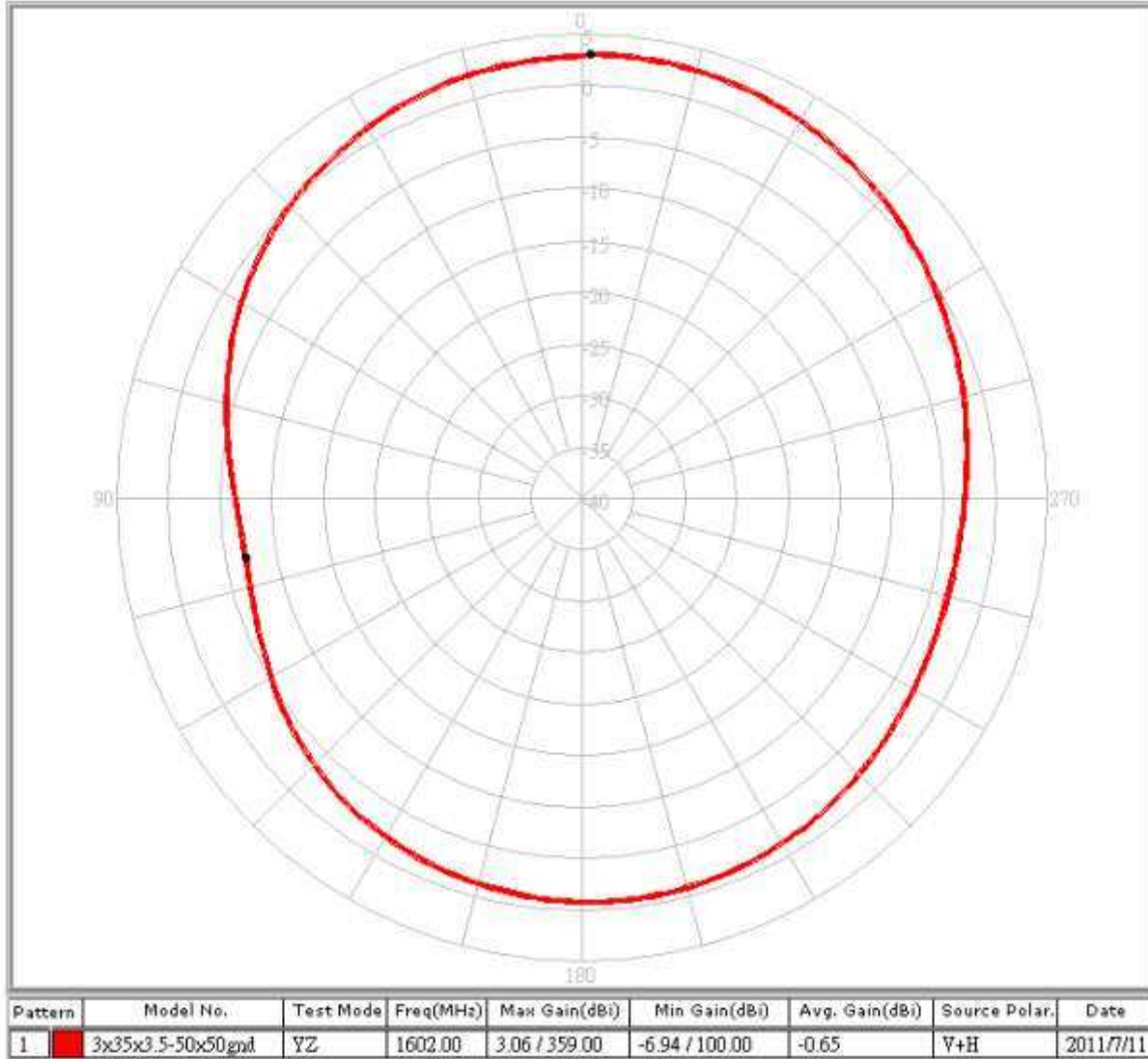

5. Packing

