

SPECIFICATION

Patent Pending

Part No. : **FXP.830.09.0100C**
Product Name : FXP.830 Freedom Wi-Fi 2.4/5 GHz Dipole
Antenna
Features : Very High Efficiency
Ground-plane Independent
MMCX(M)RA Connector
RoHS Compliant



I. Introduction

The FXP.830 has a peak gain of 1.8dBi at 2.4GHz and efficiencies of 50%, and 3-4dBi and 80-90% along bands 4.9GHz to 6GHz.

The FXP830 is a high efficiency, small, dual-band, dipole antenna for 2.4/4.9-6GHz band including Bluetooth and Wi-Fi. This Taoglas patent pending antenna is unique in the market because it is made from poly-flexible material, has a tiny form factor (42*7*.01mm) and has double-sided 3M tape for easy “peel and stick” mounting.

The FXP.830 is the ideal all-round antenna solution for squeezing into narrow spaces and still maintaining high performance, for example at the top of LCD devices.

II. Specification

ELECTRICAL		
Frequency	2.4 ~ 2.5GHz,	4.9 ~ 5.8GHz
Peak Gain (free space)	1.8dBi	3.6dBi
Peak Gain (on plastic*)	2.6dBi	5.0dBi
Average Gain (free space)	-3.0dBi	-0.6dBi
Average Gain (on plastic)	-3.0dBi	-0.7dBi
Efficiency (free space)	50%	86%
Efficiency (on plastic)	50%	84%
Polarization	Linear	
Impedance	50 Ohms	
Radiation Pattern	Omni	
Input Power	2W max.	
MECHANICAL		
Dimensions	42mm x 7mm	
Antenna Body Material	Polymer	
Cable	Gray 100mm 1.37 co-axial	
Connector	MMCX(M)RA	
ENVIRONMENTAL		
Temperature Range	-40°C to 85°C	
Humidity	Non-condensing 65°C 95% RH	

* FXP.830 is likely to be mounted on plastic in many applications so we provide the antenna measurement in both free space and mounted on a 1mm thick plastic.

III. Antenna Characteristics

III.1. Return Loss

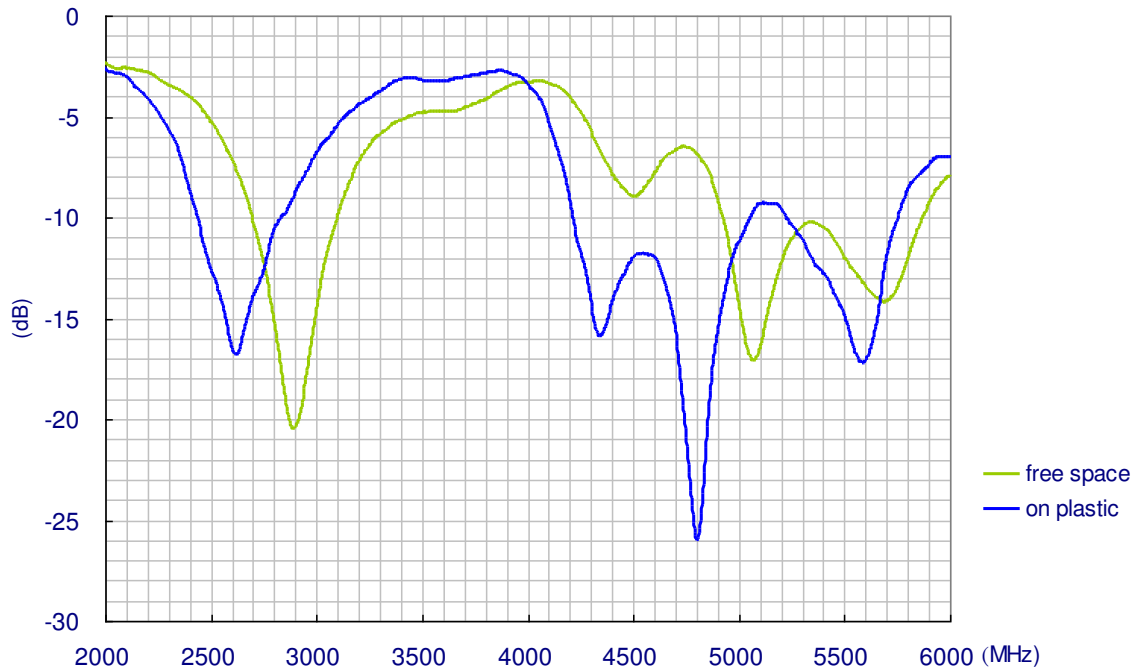

III.2. VSWR

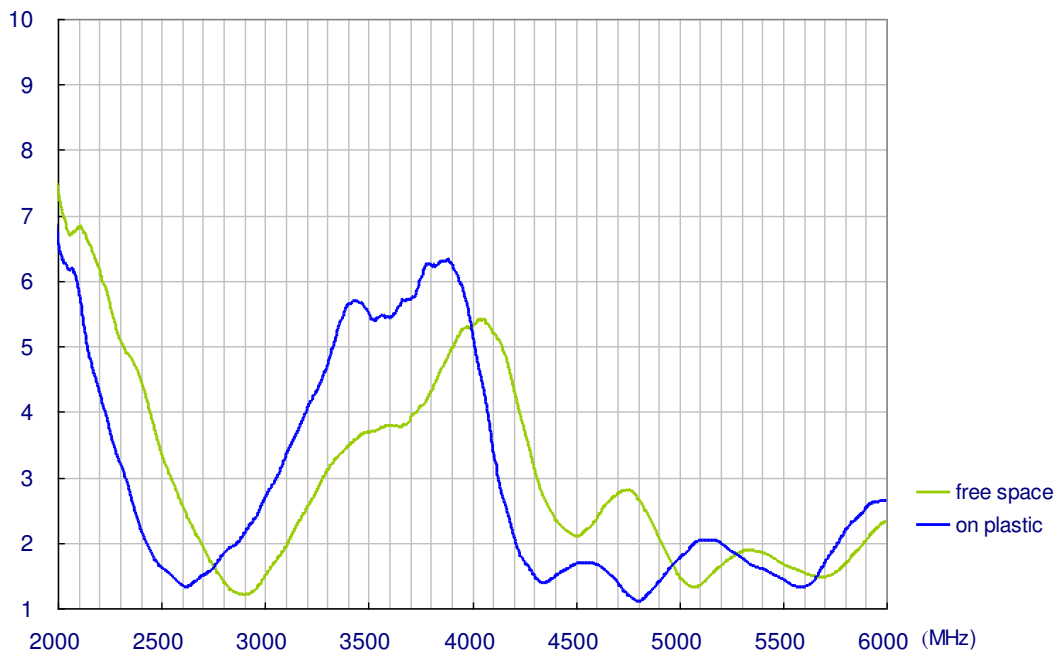

III.3. Antenna Efficiency

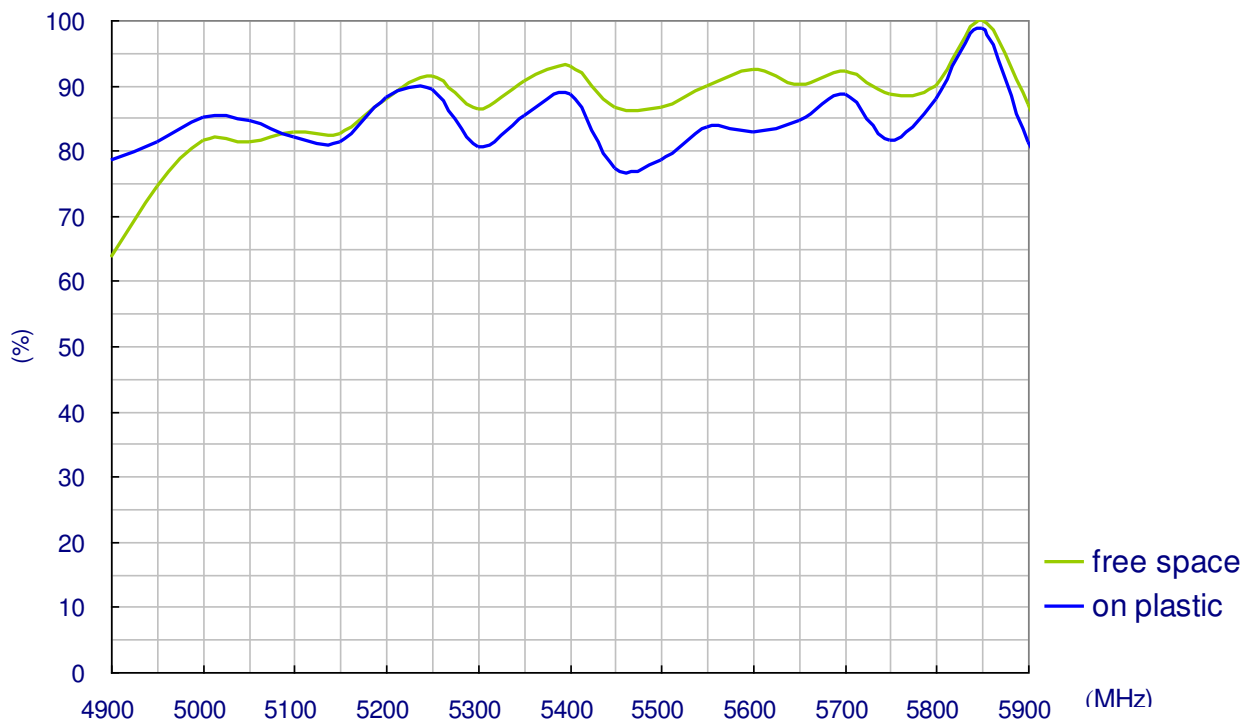
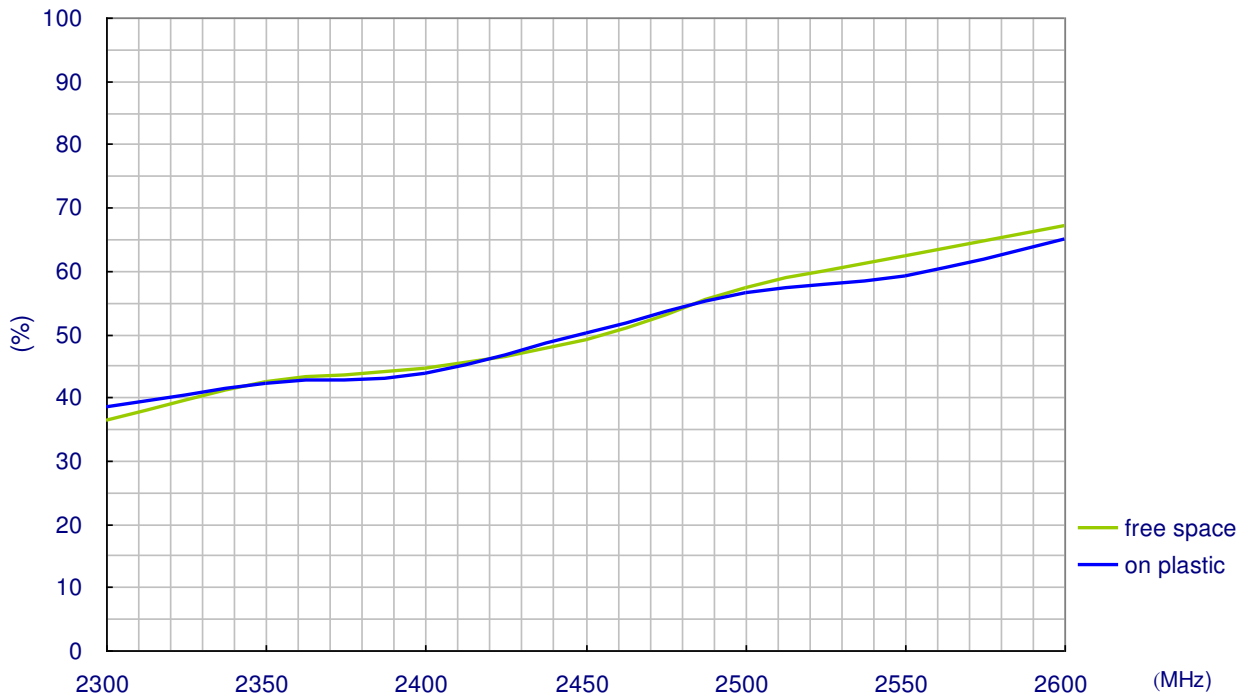

III.4. Antenna Peak Gain

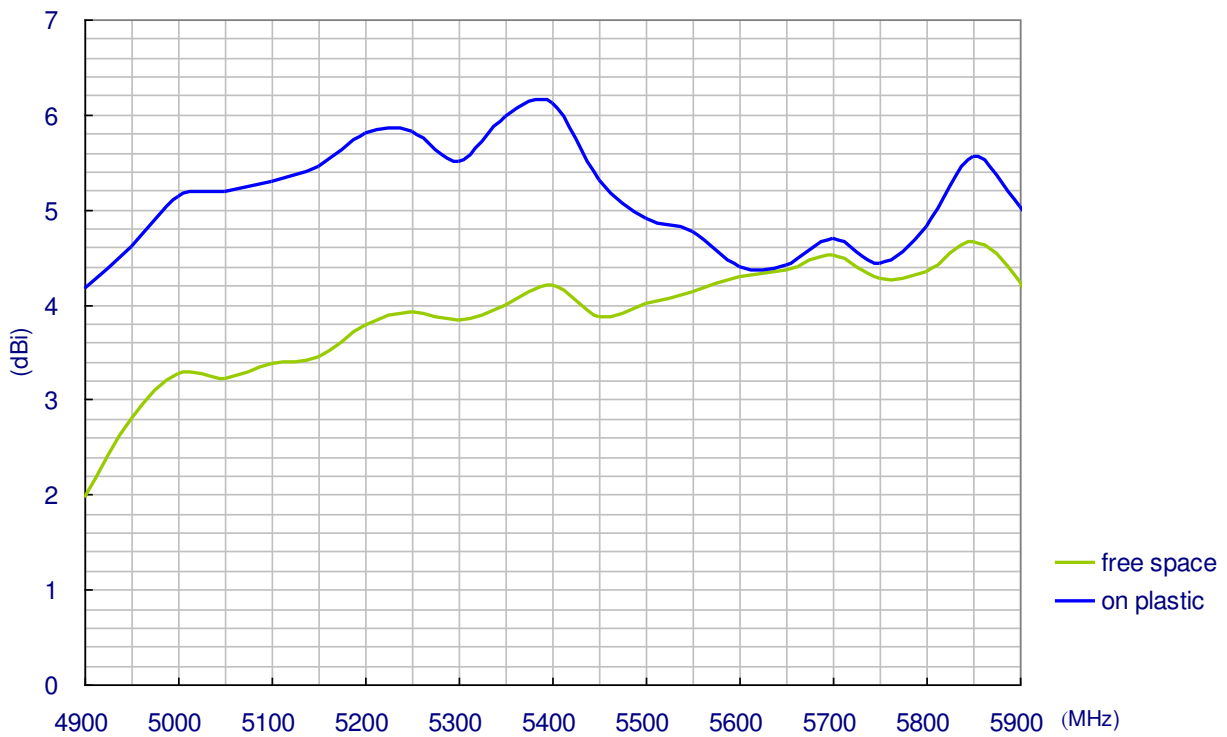
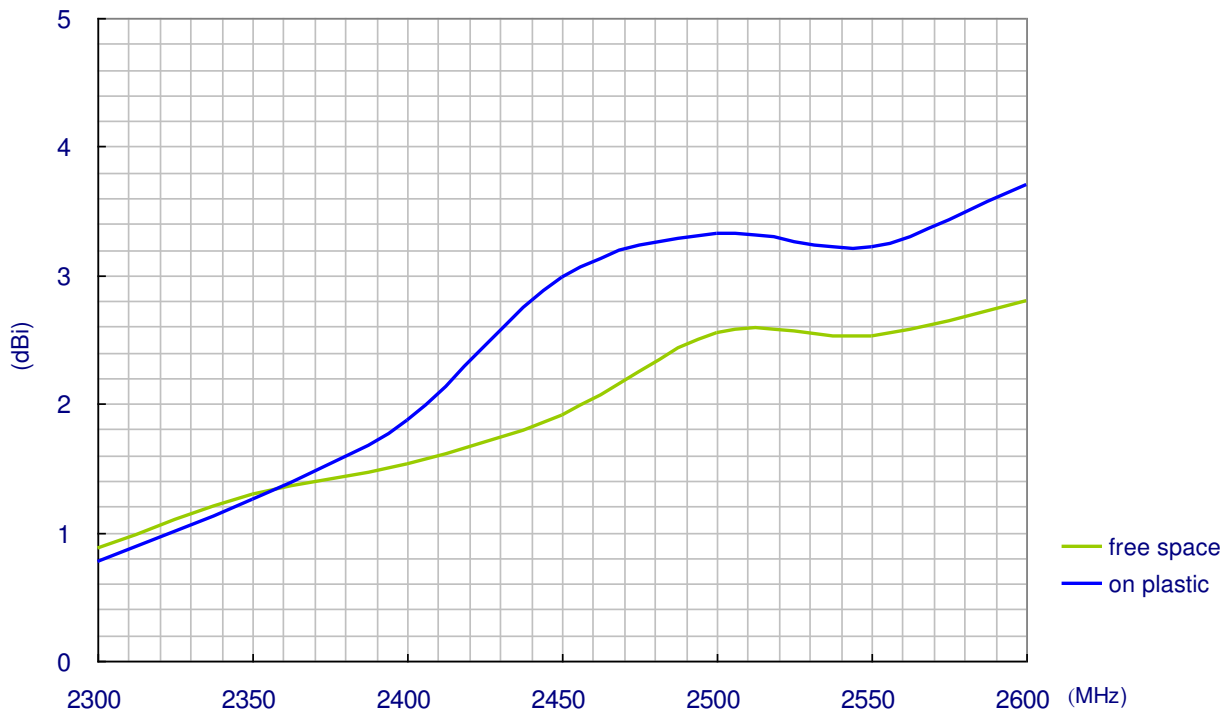

III.5. Antenna 3D Average Gain

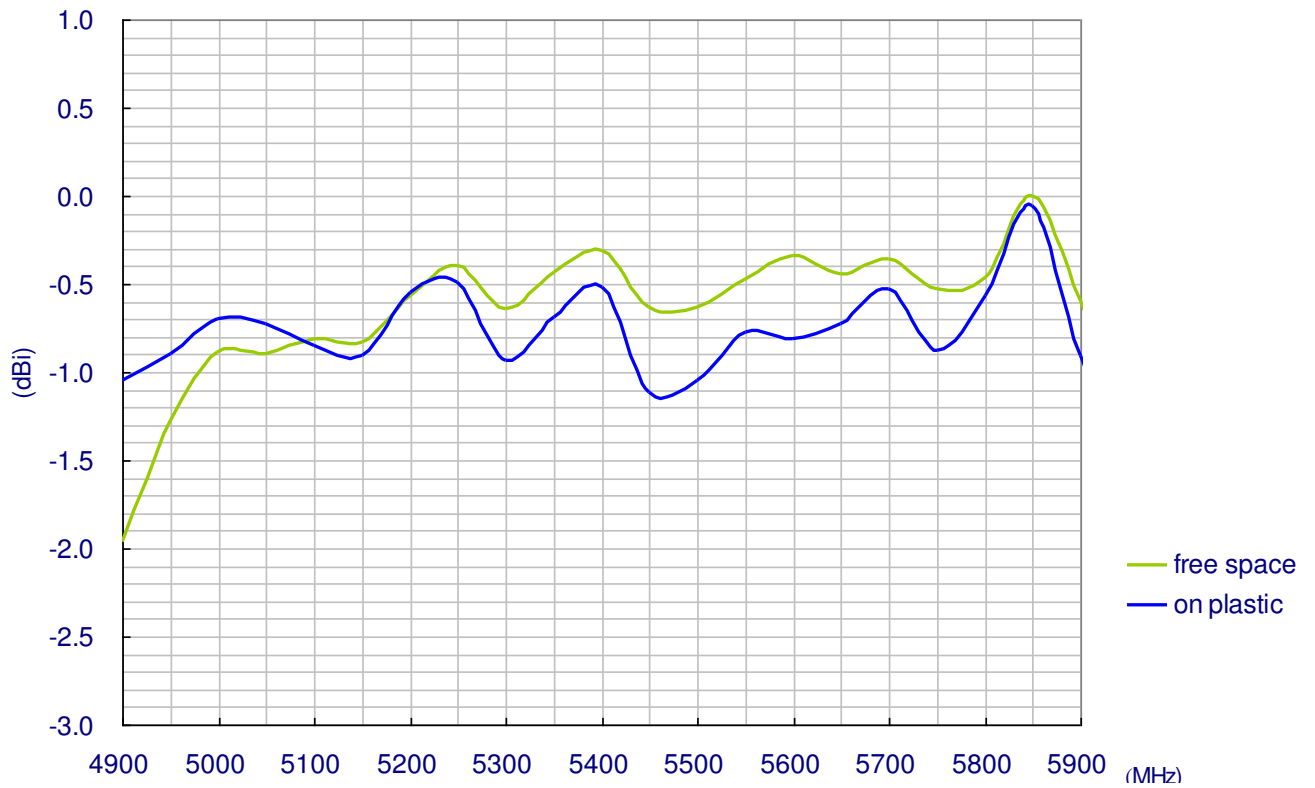
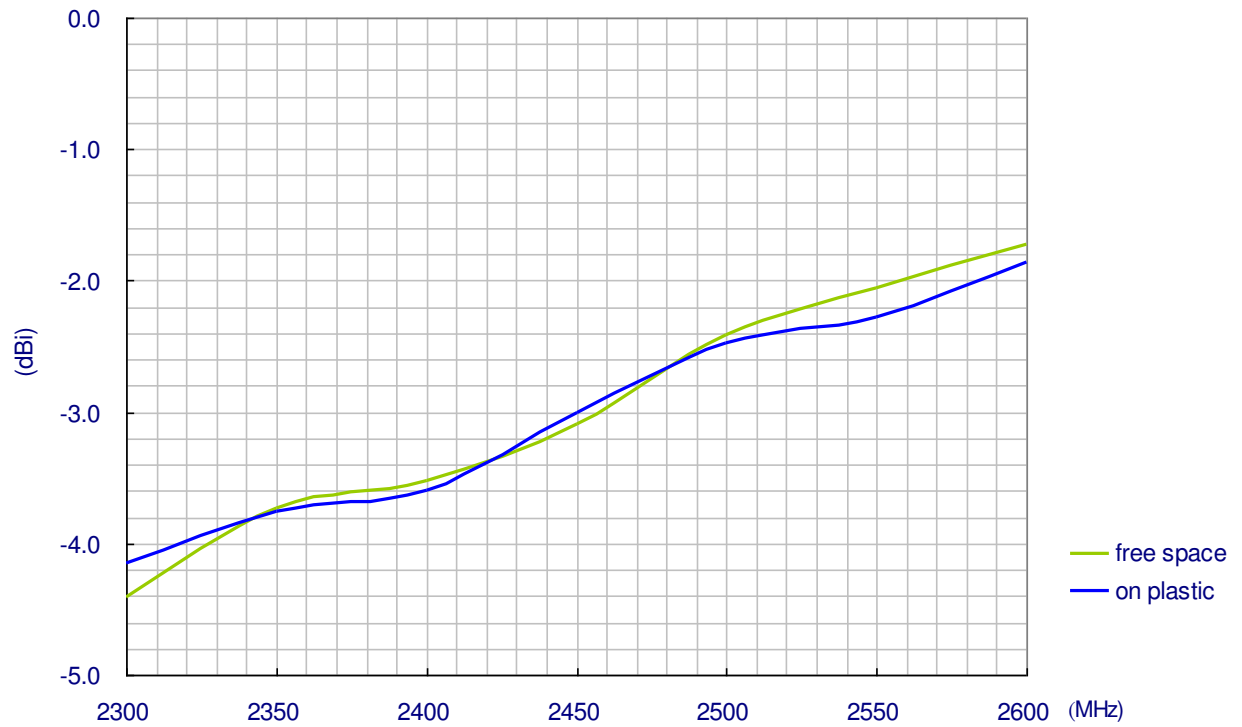

III.6. Radiation Pattern for FXP.830 on plastic

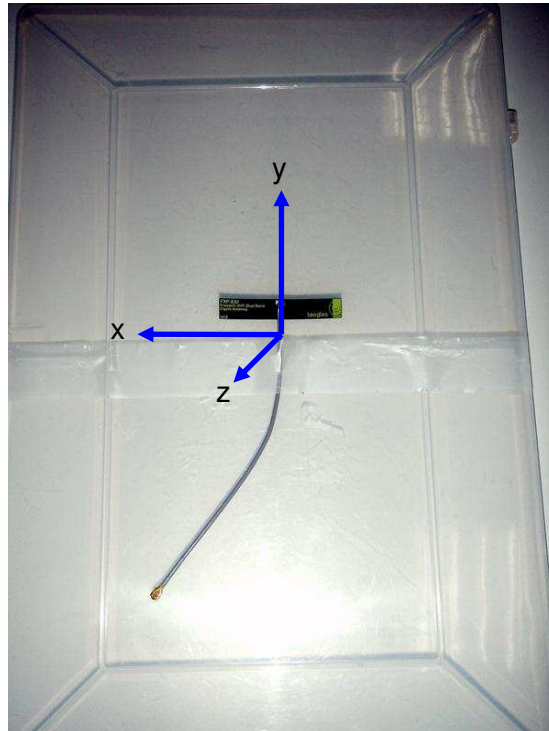

XY-plane

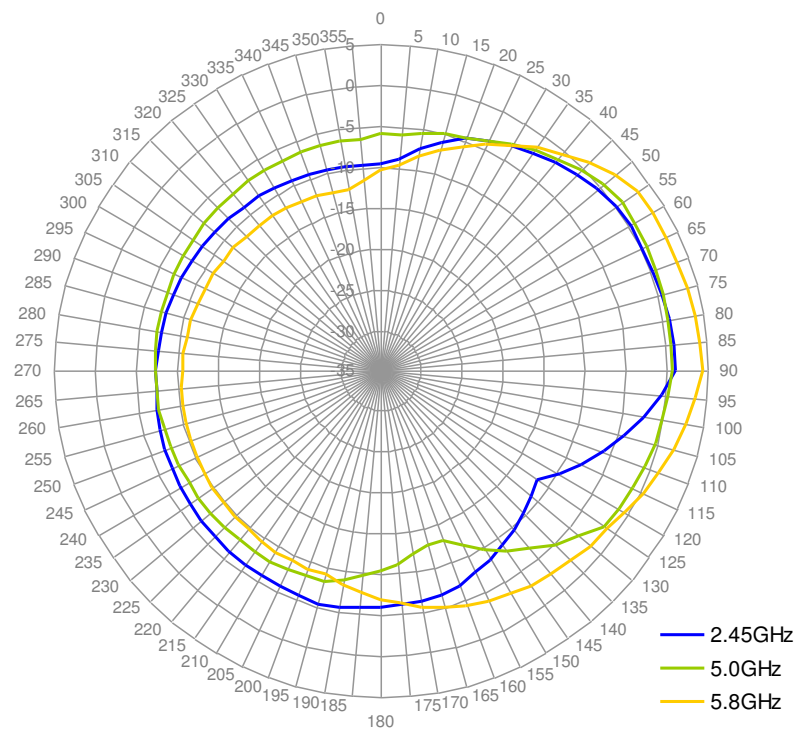

XZ-plane

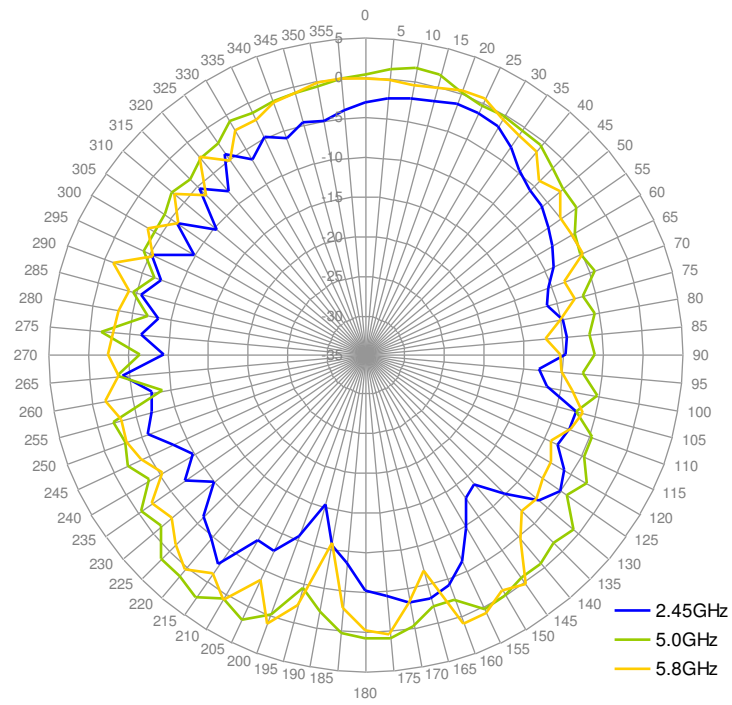

III.7. Free Space Radiation

XY-plane

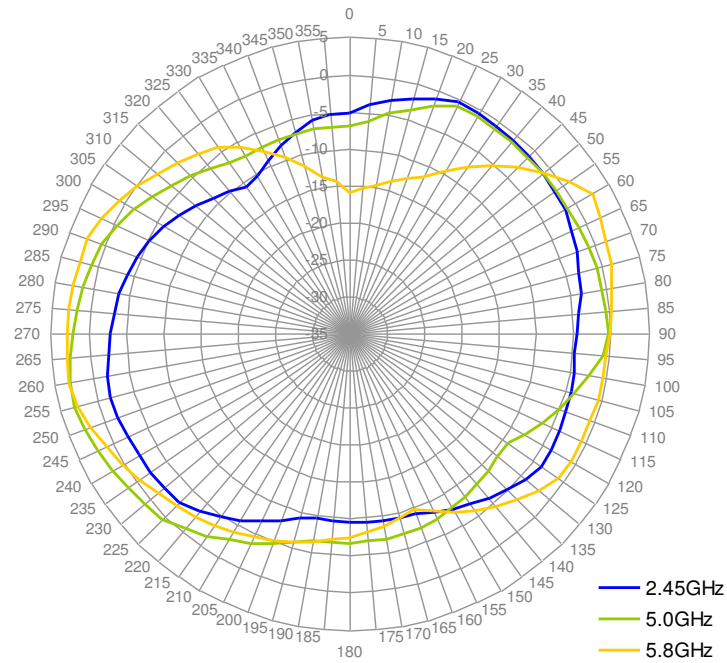

XZ-plane

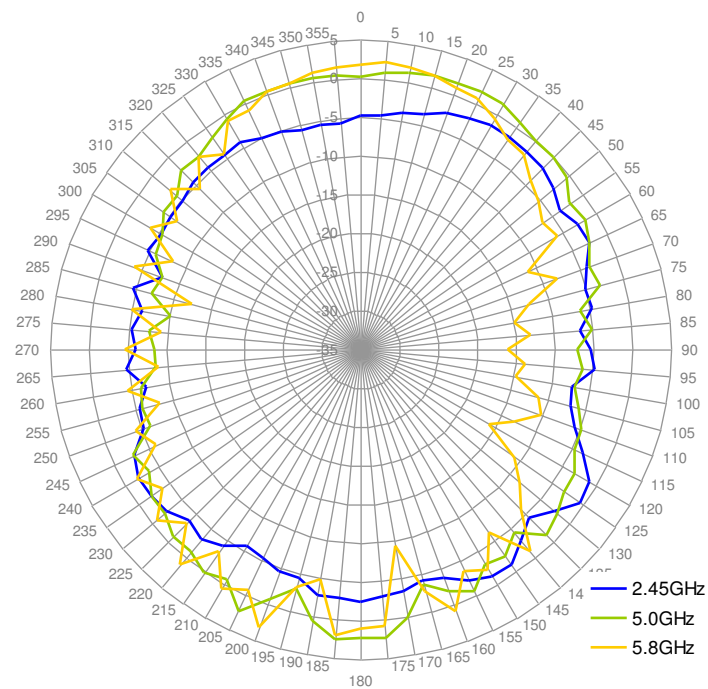

IV. Antenna Drawing

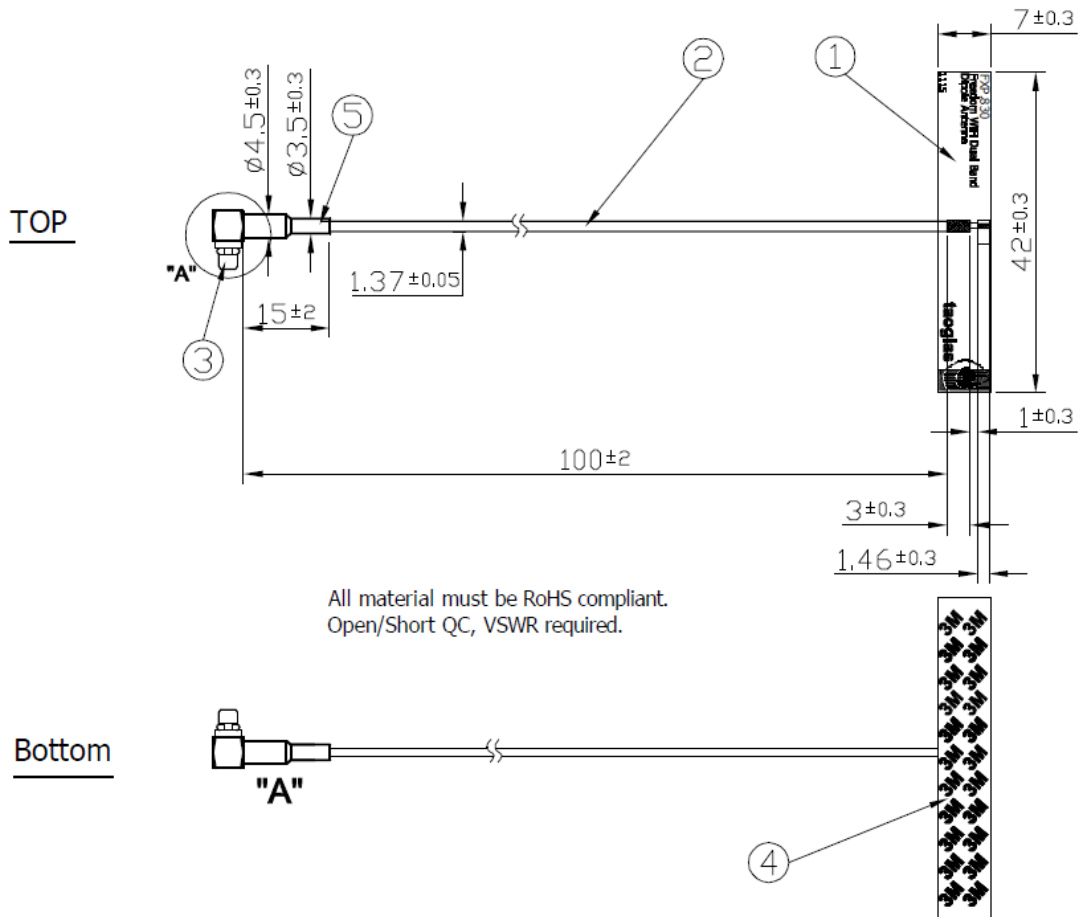

	Name	Material	Finish	QTY
①	FXP830 PCB	FPCB 0.1t	Black	1
②	1.37 Mini-Coaxial Cable	FEP	Gray	1
③	MMCX(M) RA	Brass	Gold	1
④	Double-Sided Adhesive	3M 467	Brown Liner	1
⑤	Heat Shrink Tube	PE	Black	1

NOTES:

- 1.NO DREGS OR INSUFFICIENT SOLDERING. SOLDER THICKNESS 1 ~1.7mm
- 2.THE SOLDER MUST BE SMOOTH AND FULL TO THE EDGES OF THE PAD.
THE SOLDER MUST NOT EXTEND OUTSIDE OF THE PAD AREA.
- 3.THE CONNECTOR POSITION HAS SPECIAL ORIENTATION TO THE PCB AS PER DRAWING.

