



GA.107.201111

## Specification

<b>Part No.</b>	GA.107.201111
<b>Product Name</b>	Magnetic Mount Cellular Penta-band Antenna
<b>Feature</b>	<p>Delivers high performance for all 2G/3G/3.5 networks worldwide              800MHz to 2200MHz              Magnetic mount              Superior Super Magnet – Neodymium N35              Custom cables and connectors available              RoHS Compliant</p>

## 1. Introduction

The GA.107 magnetic cellular band antenna delivers marked improvements in efficiency and gain across all common frequencies in use for cellular bands today. Now one antenna can be used in place of multiple part numbers.

Small enough to be used indoors and outdoors, the antenna performance has been designed to take advantage of any metal plate (ground-plane) it attaches to deliver best of class performance.

The GA.107 features a superior super magnet made from Neodymium N35, giving the antenna a maximum pull-force of 1.92 kilogram-force (kgf).

A reliable return loss of <10dB when mounted on a metal plate ensures it complies with the industry standards set by module makers and networks worldwide.

## 2. Specification

### Penta-Band Cellular

Communication System	AMPS	GSM	DCS	PCS	UMTS
Frequency (MHz)	824~896	880~960	1710~1880	1850~1990	1710~2170
<b>Peak Gain (dBi)</b>					
Free Space	2.6	5.0	-2.2	-2.3	-2.1
with metal ground	0.1	-0.3	-1.0	-1.0	-0.7
<b>Efficiency</b>					
Free Space	35%	45%	21%	22%	22%
With metal Ground	44%	40%	24%	26%	26%
Impedance	50Ω				
Polarization	Linear				
Radiation Pattern	Omni-Directional				
V.S.W.R.	< 2.0 : 1				
Input Power	50 W				

### Mechanical

Dimensions	Length 116mm, Ø 29.5mm Base
Cable Type	RG-174
Cable Length	2M
Pull Force	1.92 kgf Max.
Casing	300 series stainless steel with black Duracoat finish
Connector	SMA Male

### Environmental

Temperature Range	-40°C to 85°C
Humidity	Non-condensing 65°C 95% RH

\* Note – RF characteristic shown in this data sheet is measured with RG-174 and SMA(M) connector in room temperature.

### 3. Antenna Characteristics

#### 3.1 Return Loss

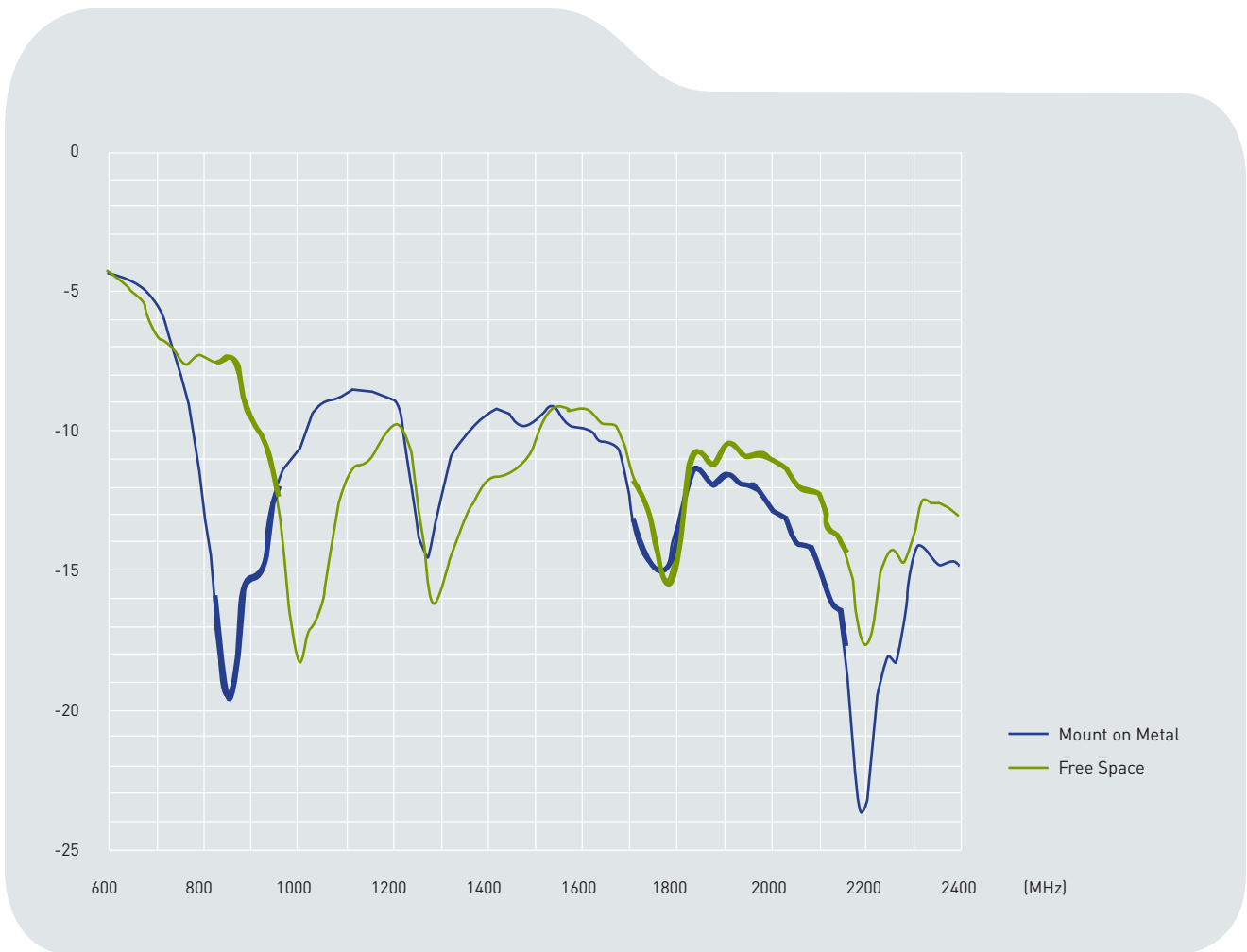

The highlighted parts are cellular operation frequency.

### 3. Antenna Characteristics

#### 3.2 Antenna Efficiency

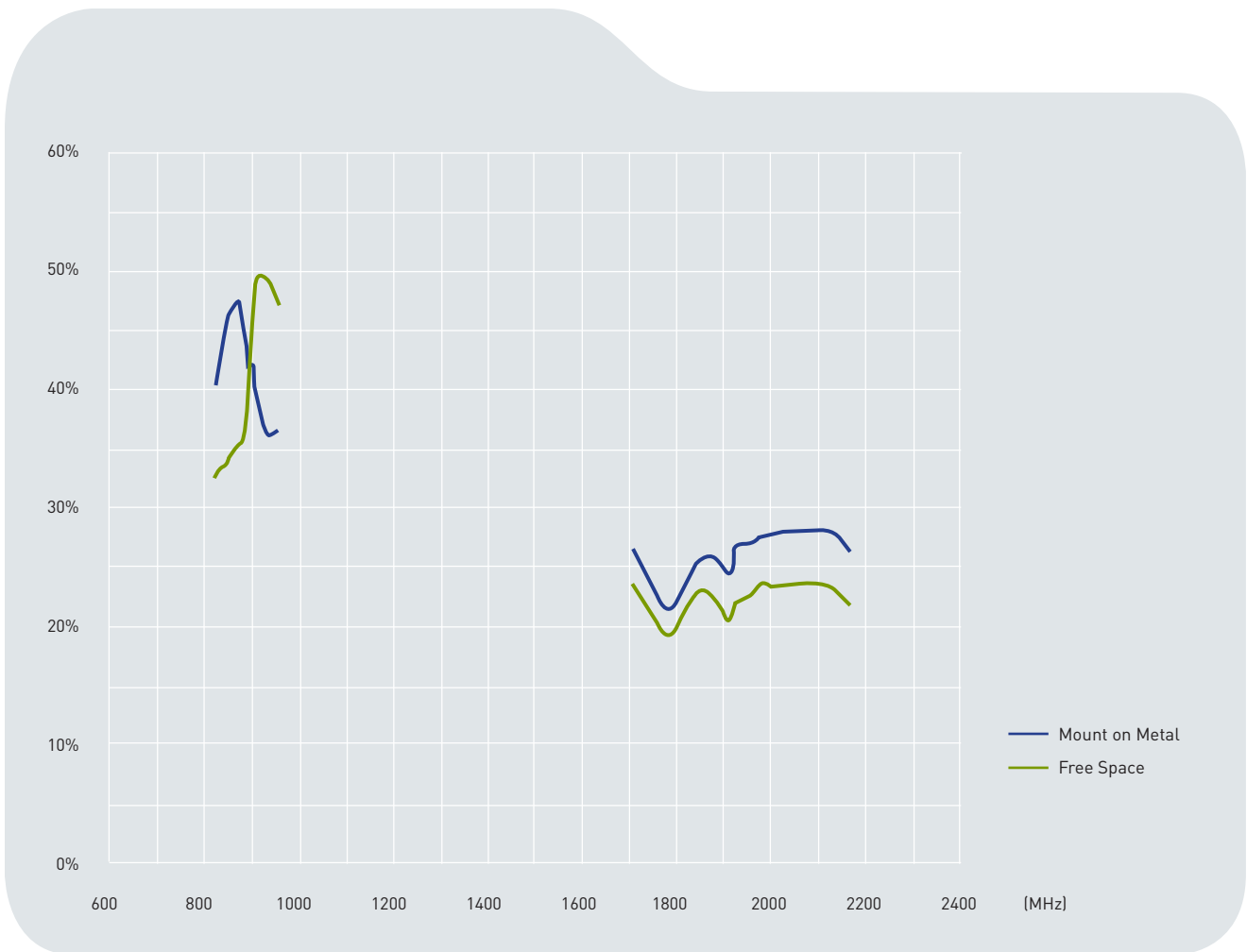

## 4. Antenna Radiation Patterns

### 4.1 Radiation Pattern (Free Space)

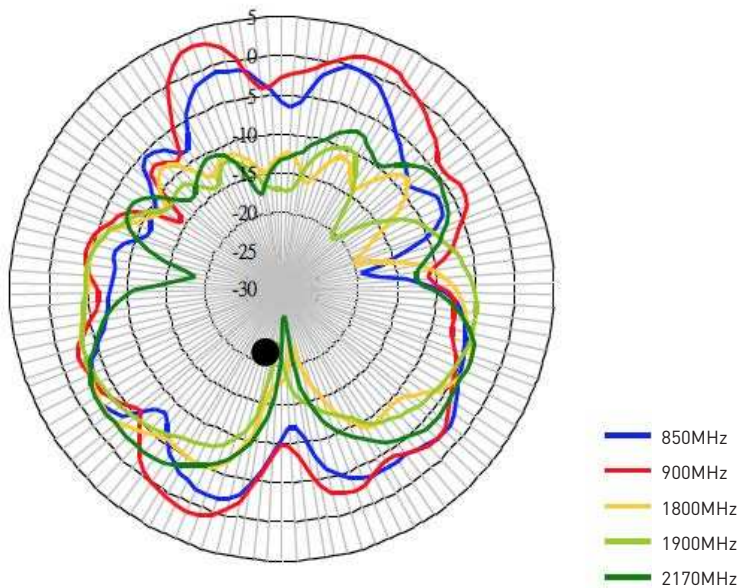
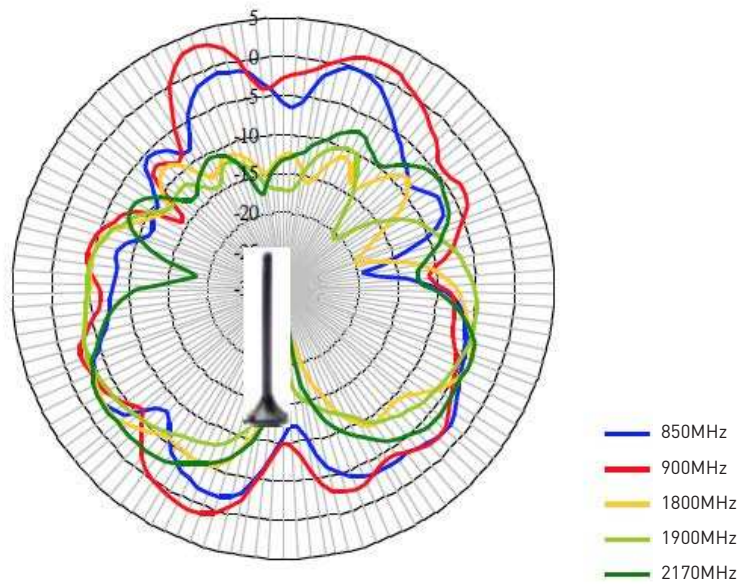

## 4. Antenna Radiation Patterns

### 4.2 Radiation Pattern (On Ground Plane)

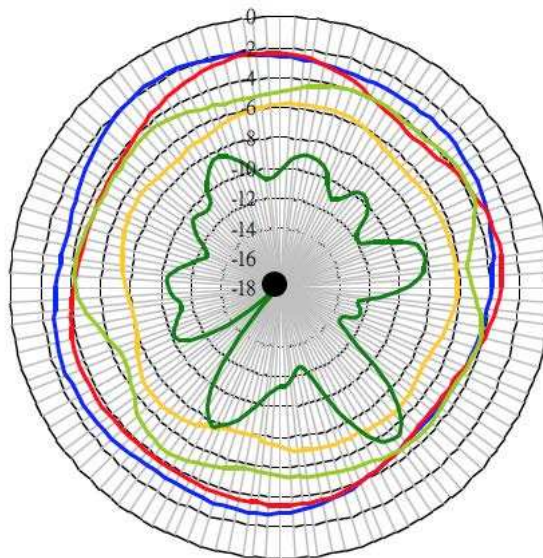
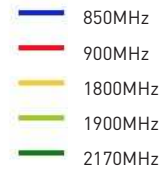
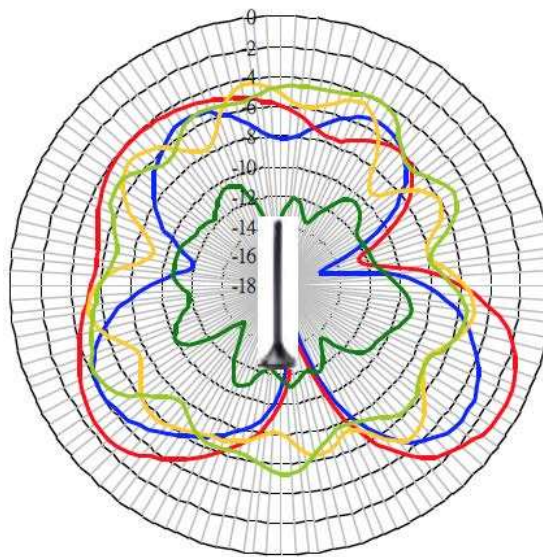

## 5. Magnetic Pull Force (kilogram - force (kgf))

<b>Distance (mm)</b>	0	0.1	0.2	0.3	0.4	0.5	0.6	0.7	0.8	0.9	1
<b>Pull force (kgf)</b>	0	1.37	1.61	1.85	1.9	1.92	1.64	1.42	1.28	1.15	1.06
<b>Distance (mm)</b>	1.1	1.2	1.3	1.4	1.5	1.6	1.7	1.8	1.9	2	2.1
<b>Pull force (kgf)</b>	0.98	0.92	0.86	0.82	0.76	0.74	0.7	0.68	0.64	0.62	0.6
<b>Distance (mm)</b>	2.2	2.3	2.4	2.5	2.6	2.7	2.8	2.9	3	3.1	3.2
<b>Pull force (kgf)</b>	0.58	0.56	0.54	0.52	0.52	0.5	0.49	0.47	0.46	0.45	0.44
<b>Distance (mm)</b>	3.3	3.4	3.5	3.6	3.7	3.8	3.9	4	4.1	4.2	4.3
<b>Pull force (kgf)</b>	0.44	0.42	0.42	0.42	0.4	0.4	0.4	0.38	0.36	0.36	0.36
<b>Distance (mm)</b>	4.4	4.5	4.6	4.7	4.8	4.9	5				
<b>Pull force (kgf)</b>	0.36	0.36	0.36	0.34	0.35	0.34	0.34				

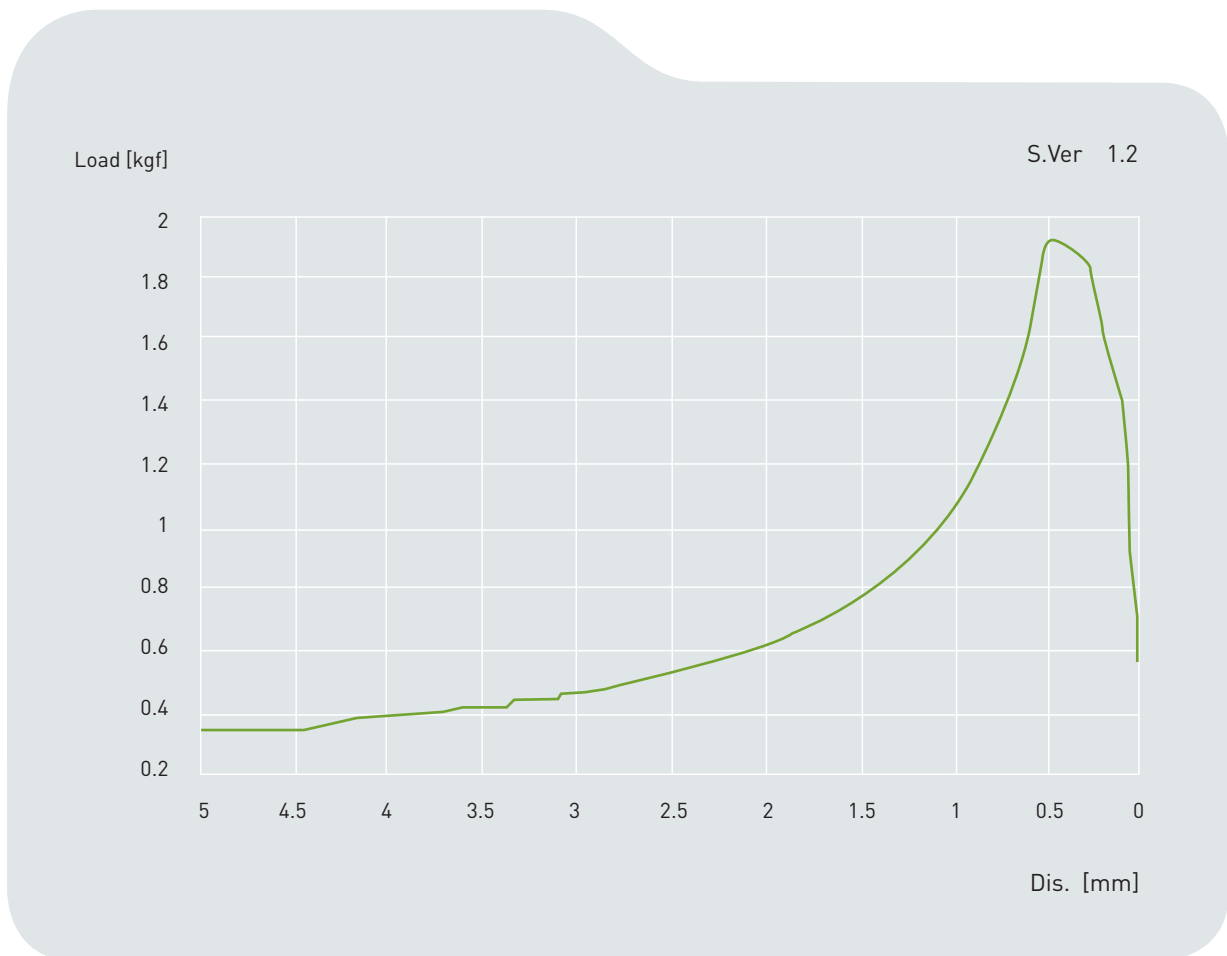



## 6. Drawing

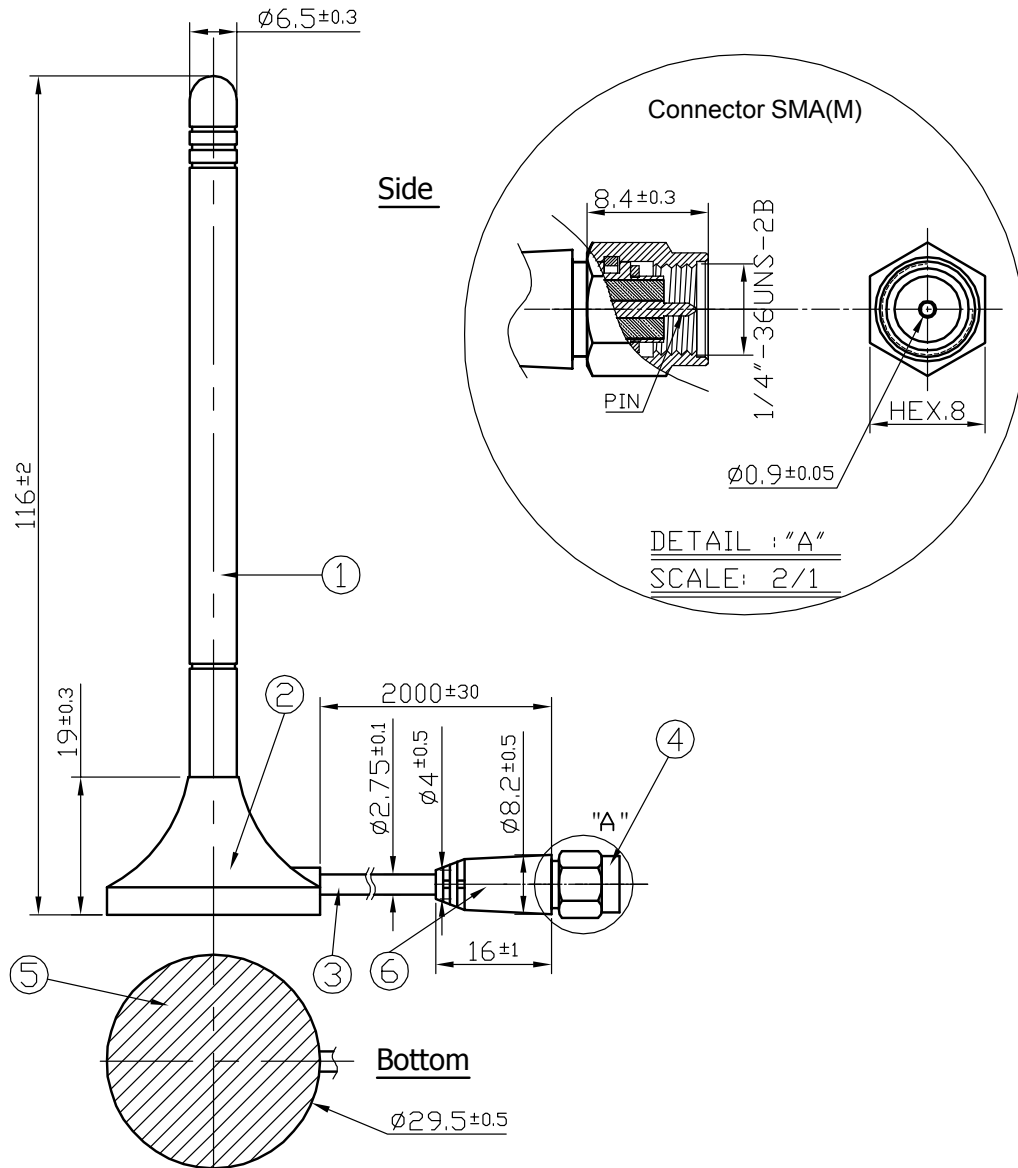

	Name	Material	Finish	QTY
1	GA.107 Antenna Housing	TPU	Black	1
2	Holder	ABS	Black	1
3	RG174	PVC	Black	1
4	SMA(M)	Brass	Gold	1
5	Sticker	Polyester	White	1
6	Strain Relief Bushing	PE	Black	1

## 7. Packaging

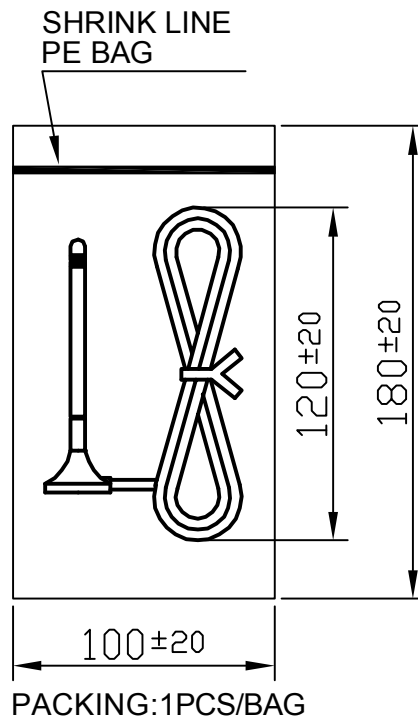

Taoglas makes no warranties based on the accuracy or completeness of the contents of this document and reserves the right to make changes to specifications and

product descriptions at any time without notice. Taoglas reserves all rights to this document and the information contained herein.

Reproduction, use or disclosure to third parties without express permission is strictly prohibited.  
Copyright © Taoglas Ltd.