

SPECIFICATION

Part No. : **GP.1575.25.4.A.02**

Product Name : **4mm thick GPS Patch Antenna**

Features : 25mm*25mm*4mm
Halogen Free
ROHS Compliant

:



1. Introduction

This miniaturized ceramic GPS patch antenna is based on smart **XtremeGain™** technology. It is mounted via pin and double-sided adhesive and has been tuned as optimal solution for the customer device environment.

2. Specification Table

Original Patch Specification tested on 50*50mm ground plane

No	Parameter	Specification
1	Range of Receiving Frequency	1575.42MHz +/- 1.023MHz
	Center Frequency	1575MHz +/- 3MHz
2	Impedance	50Ω
3	Bandwidth	10 MHz min Return Loss <-10dB
4	VSWR	1.5 max
5	Gain toward Zenith	3.5 dBi typ.
6	Gain at 10°Elevation	-2.5 dBi typ.
7	Axial Ratio	3dB Max.
8	Polarization	Right Hand Circular Polarization
9	Frequency Temperature Coefficient (Tf)	0 ± 20ppm/°C
	Operating Temperature	-40°C to +85°C

3. Electrical Specification

3.1 Smith Chart

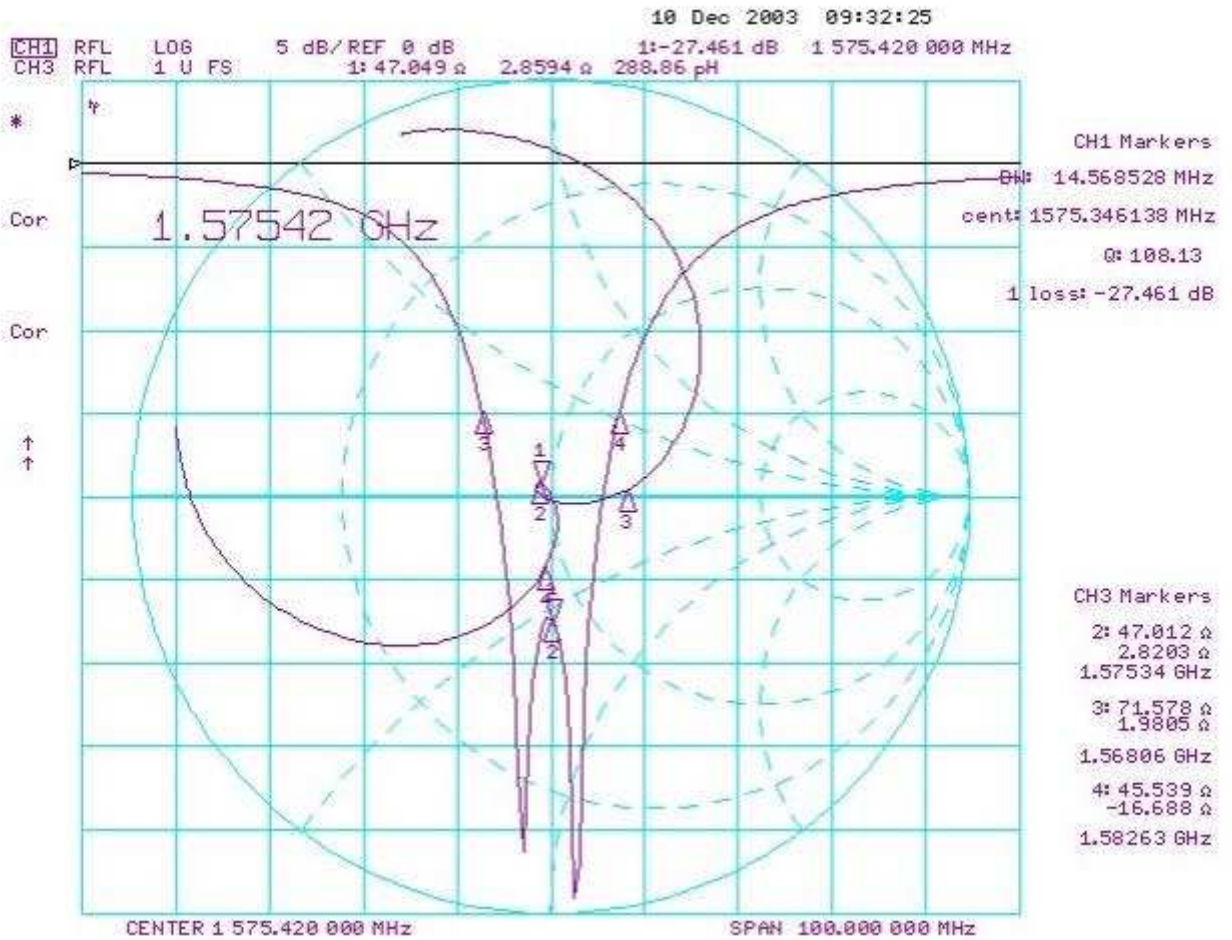

4. 2D Mechanical Drawing

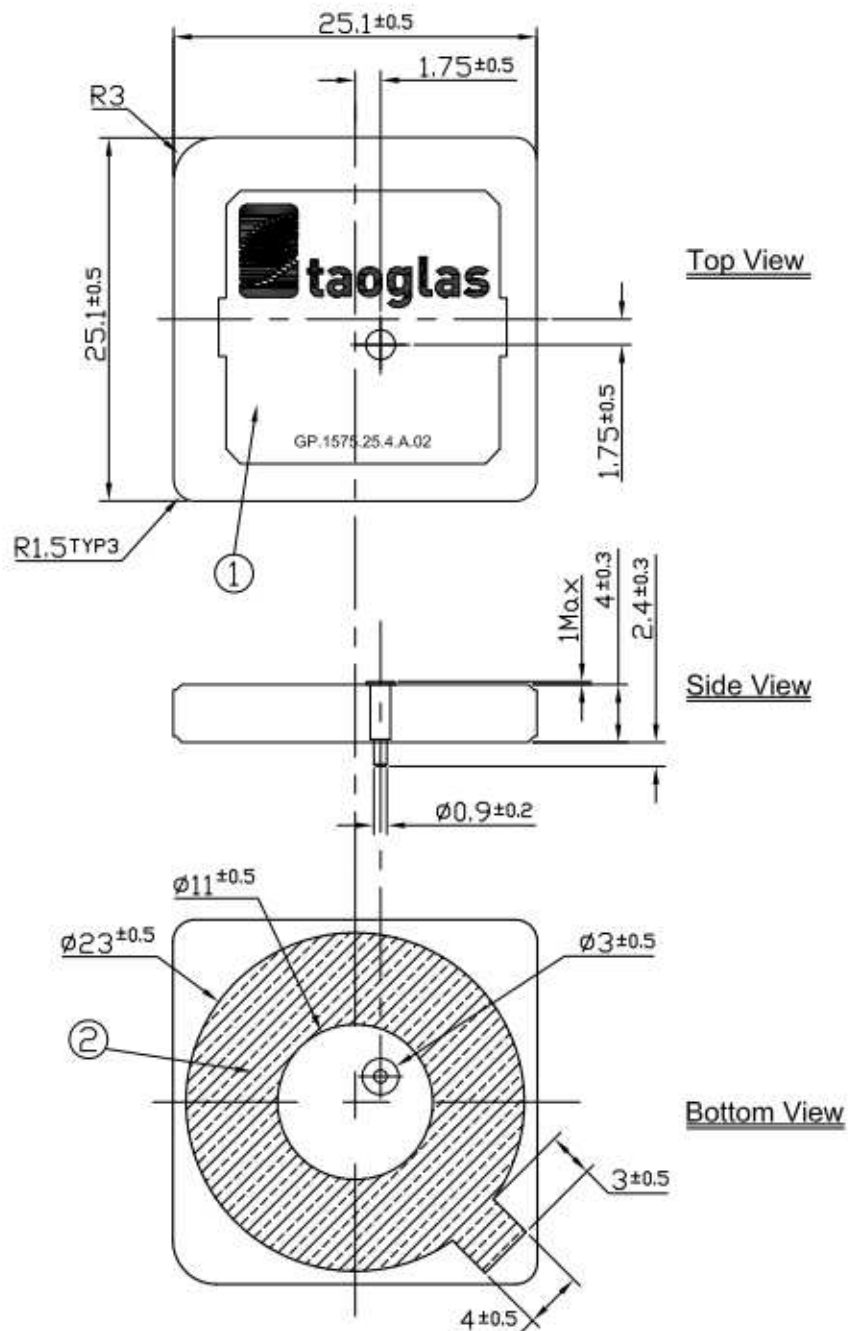

NOTES:

1. Double sided adhesive area 

	Name	Material	Finish	QTY
1	GP.1575 Patch 25x25x4	Ceramic	Clear	1
2	Double sided Adhesive	NITTO 5015	White Liner	1

5.1 Layout Dimension

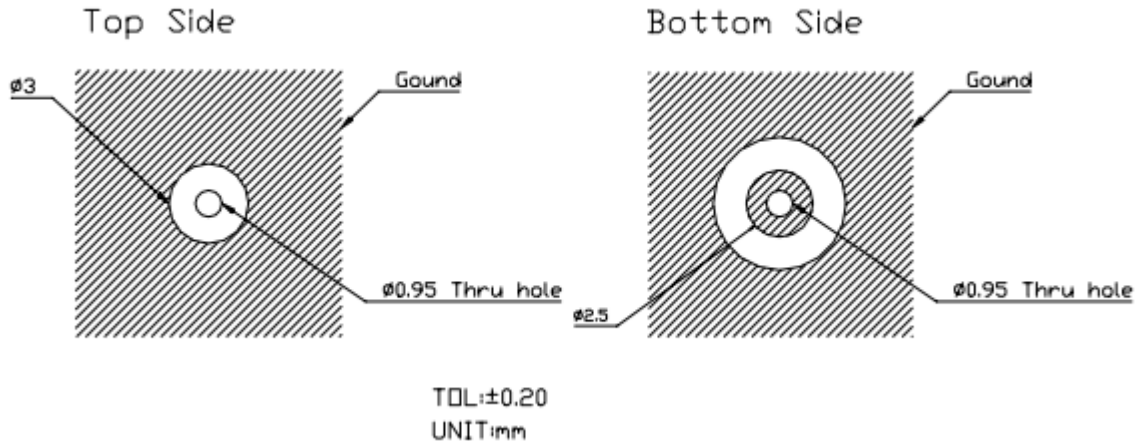

*Note Layout Dimensions may be affected by the thickness of the PCB

5. Test Jig and Dimension

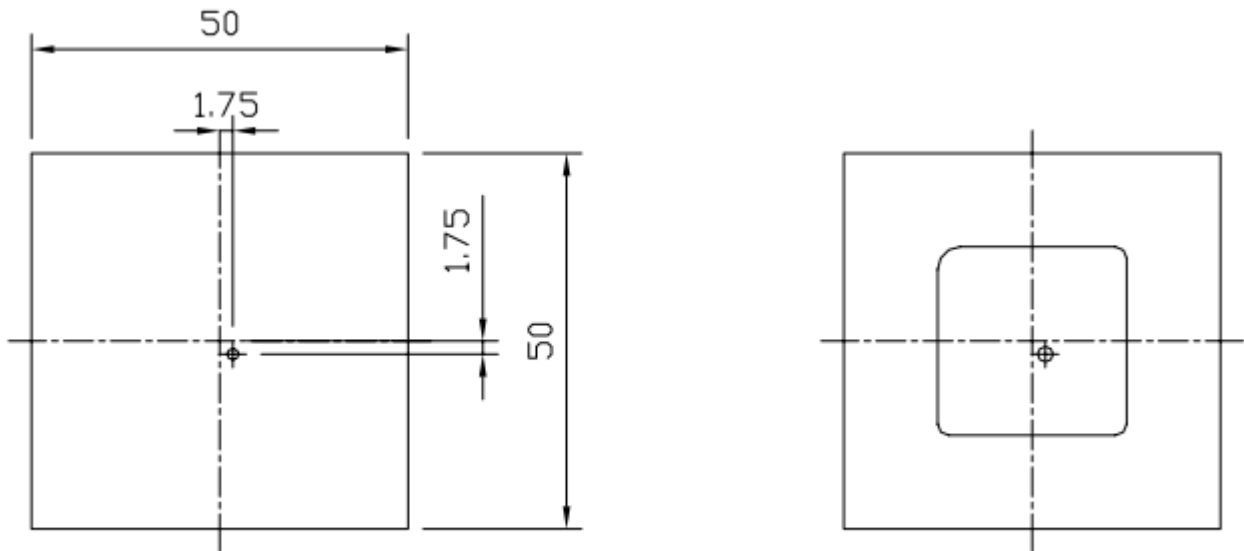

5.1 Test Fixture Antenna Setup and Measurements

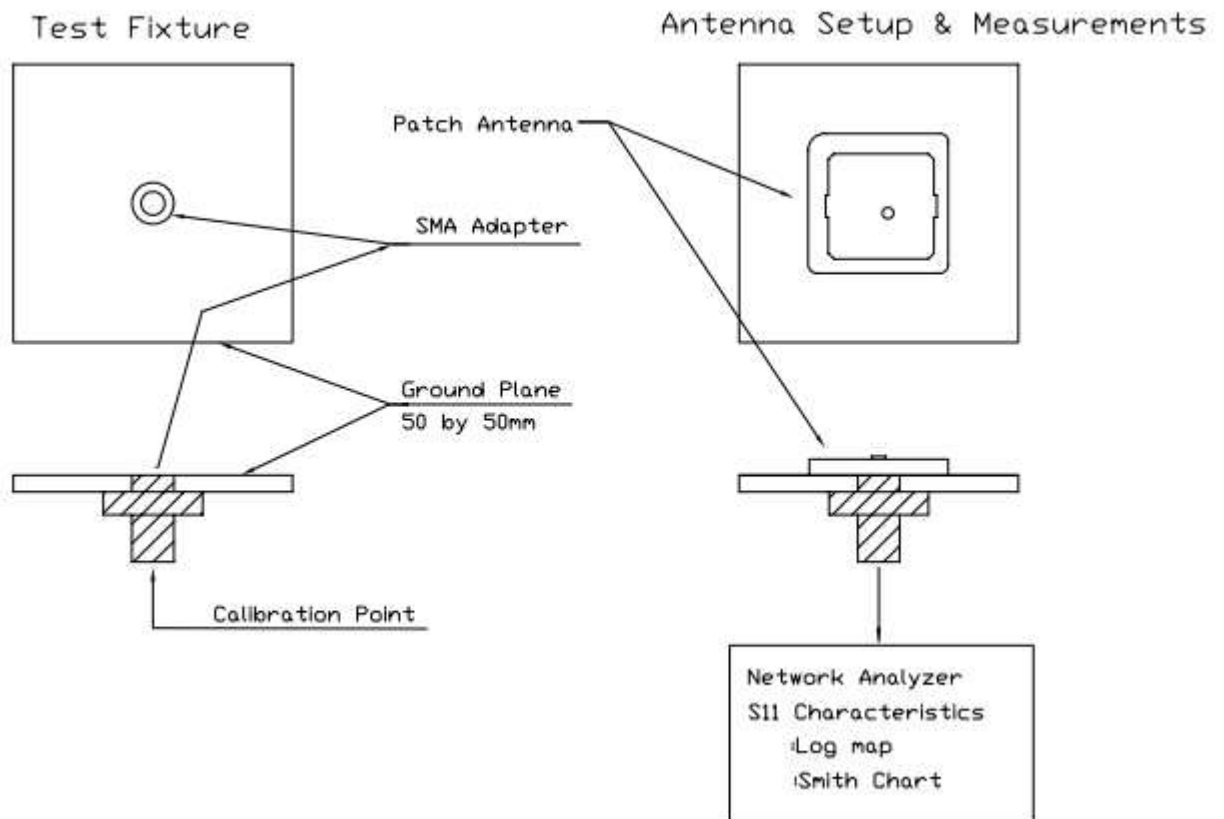

6. Packaging

50 pieces per Tray

200 per Inner Carton

4 x 200 – 800 pieces per Outer Carton

