



Underside View
(this side faces the passenger)



Top View
(this side faces the sky)

Stingray

MA203.A.AB.045

Specification

Part No.	MA203.A.AB.045
Product Name	Stingray GPS/Penta-band Cellular Adhesive Antenna
Feature	High gain LNA up to 32dB (GSM/CDMA/PCS/DCS/UMTS/GPRS/EDGE/ HSPA) Height 10.8mm Diameter 55.1mm IP65 Waterproof Fakra Connector ROHS Compliant

1. Introduction

This is a combination high performance GPS and Penta-band Cellular (GSM/CDMA/PCS/DCS/ / UMTS / GPRS / EDGE/ HSPA) antenna to simplify AVL or Fleet management antenna systems worldwide.

Its high quality low profile covert housing can be attached onto the glass or even out of sight under the dashboard. This combination of a high gain GPS antenna and a leading edge Penta band

cellular antenna is ideal for those applications that require durability, small size and covert installation, and reliable reception and transmission crossing through different mobile networks.

1.1 Features

GPS

High LNA Gain up to 32 dB

Antenna Gain 30 ± 2 dB

Miniaturized to 55.15x12mm

Low Noise 1.5 dB max

Cellular

Advanced Penta-Band Cellular Antenna
(GSM/CDMA/PCS/DCS/UMTS/GPRS/EDGE/HSPA)

Other

Water Resistant IP 65 (IP 67 MA.203 version also available)

Quality textured covert design. Low profile

UV resistant ABS housing

Comes with high grade 3M double sided tape for quick and easy mounting

Fakra code C (blue) on GPS and code D (violet) on GSM

Optional cables and connectors

2. Specification

2.1 GPS Antenna

GPS

Centre Frequency	1575.42MHz
Bandwidth	10MHz
Average Gain	28dBic typ. (@DC 3V)
Radiation Efficiency	50%
Gain @ Zenith	4.0dBic typ.
Axial Ratio	3.0dB max.
Polarization	Right Hand Circular
VSWR	≤2.0
Impedance	50Ω
DC Power Input Range	3 ~ 5 V
DC input	3V
LNA Gain(Typ.)	28dB
Noise Figure(Typ.)	1.5dB
Power Consumption	7~9mA
Band Attenuation	±50MHz 40dB
Cable	1M RG174 standard, fully customizable
Connector	SMA(M) standard, standard, fully customizable

2.2 Cellular Antenna

Cellular

Frequency (MHz)	824~894	880~960	1710~1880	1850~1990	2110~2170
Peak gain (dBi)	>2.5	>0.0	>1.5	>2.5	>0.5
Efficiency	>60%	>45%	>40%	>45%	>50%
Impedance	50Ω				
Polarization	Linear				
VSWR	3 max.				
Cable	1M RG-174 standard, fully customizable				
Connector	SMA(M) standard, fully customizable				

3. Test Setup

3.1 Configuration of SATIMO



Agilent E5071B Network Analyzer



Anritsu 68147C Signal Generator

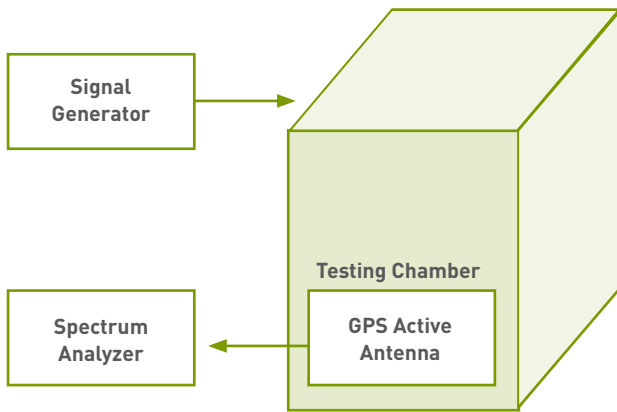

Testing Chamber



Anritsu MS2721A Spectrum

Cable attenuation (dB/100mm)

GHz	0.5	1	1.5	2	2.5	3	3.5	4	4.5	5	5.5	6
RG-174	67	100	127	153	138	183	207	229	252	272	291	311
CFD-200	26	39	49	58	66	73		86		98		109

4. GPS Antenna Characteristics

4.1 Patch Antenna S11

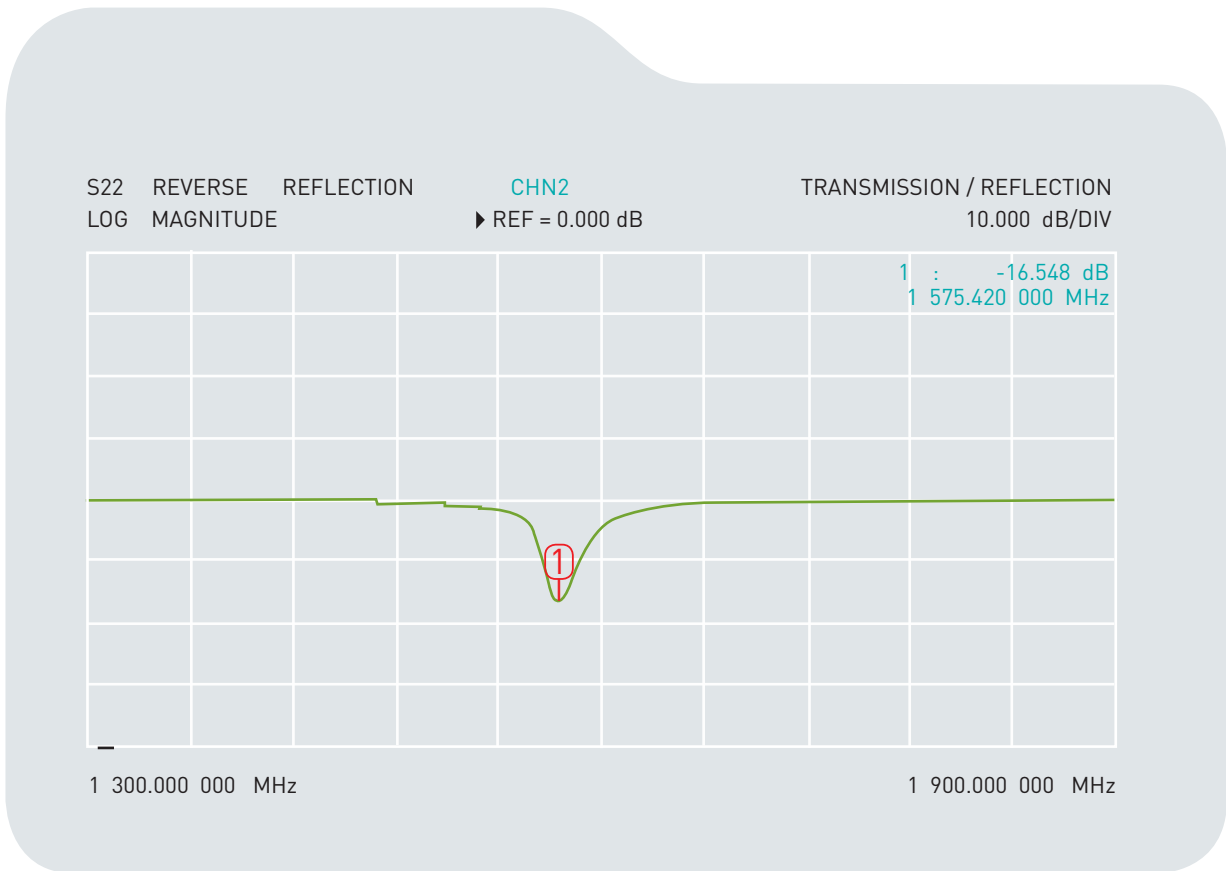

4.2 GPS Antenna Pattern (XZ Plane)

Far-Field amplitude of GPS_1_070108.nsi

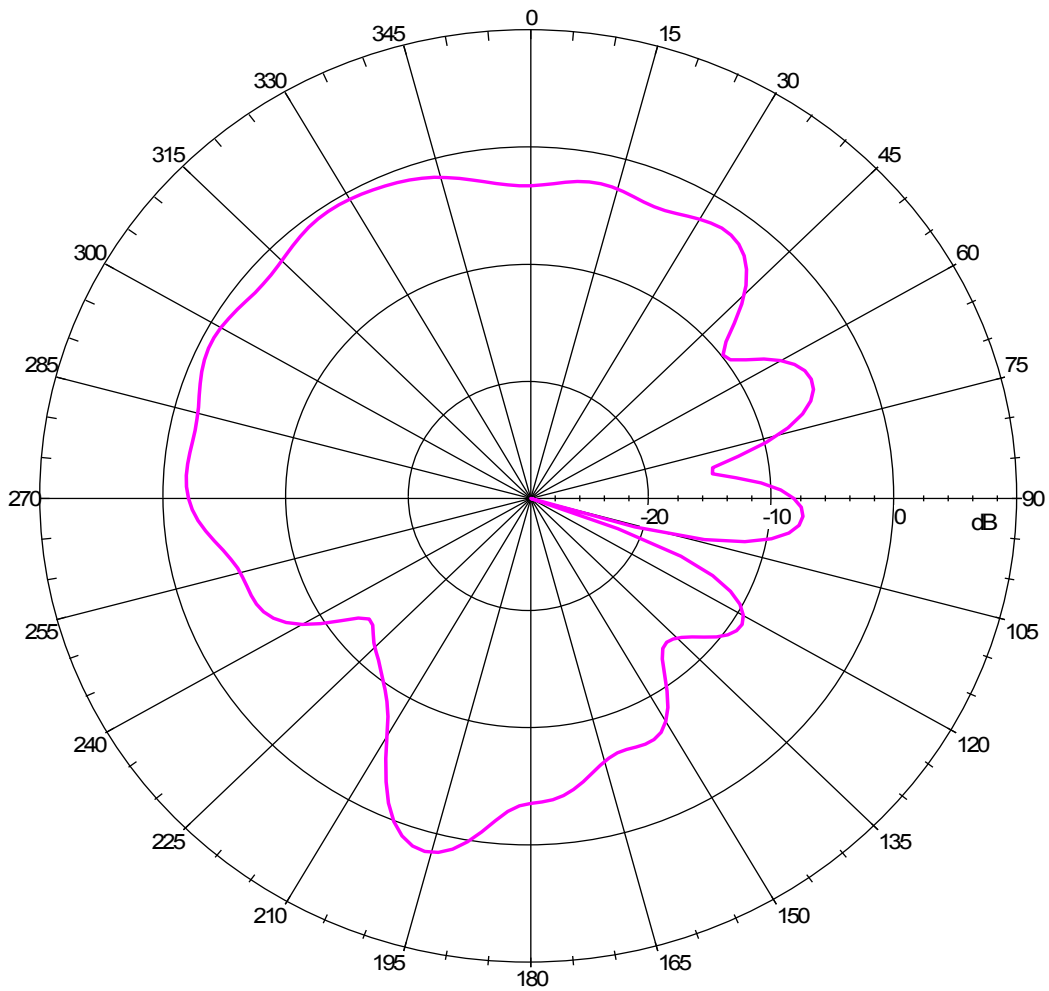

4.3 GPS Antenna Pattern (YZ Plane)

Far-Field amplitude of GPS_1_070108.nsi

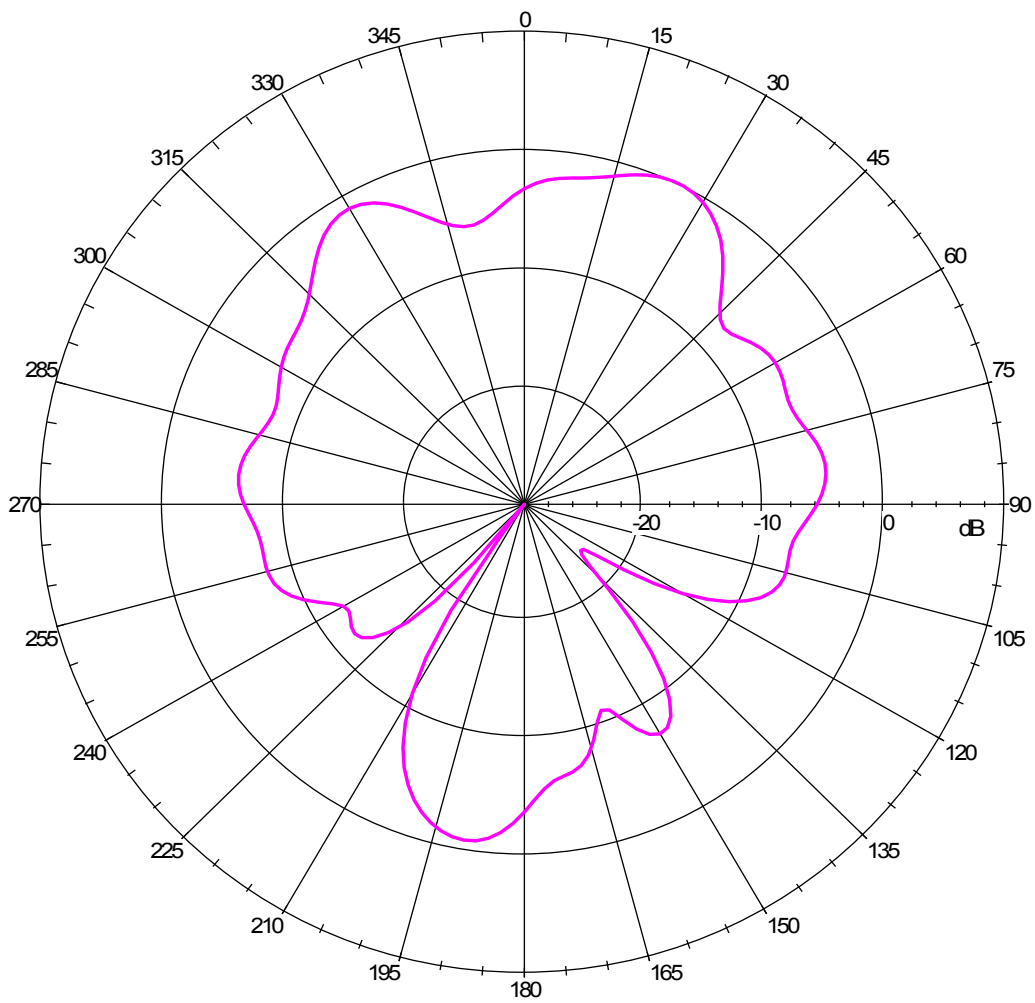

4.4 GPS Antenna Gain (with LNA)

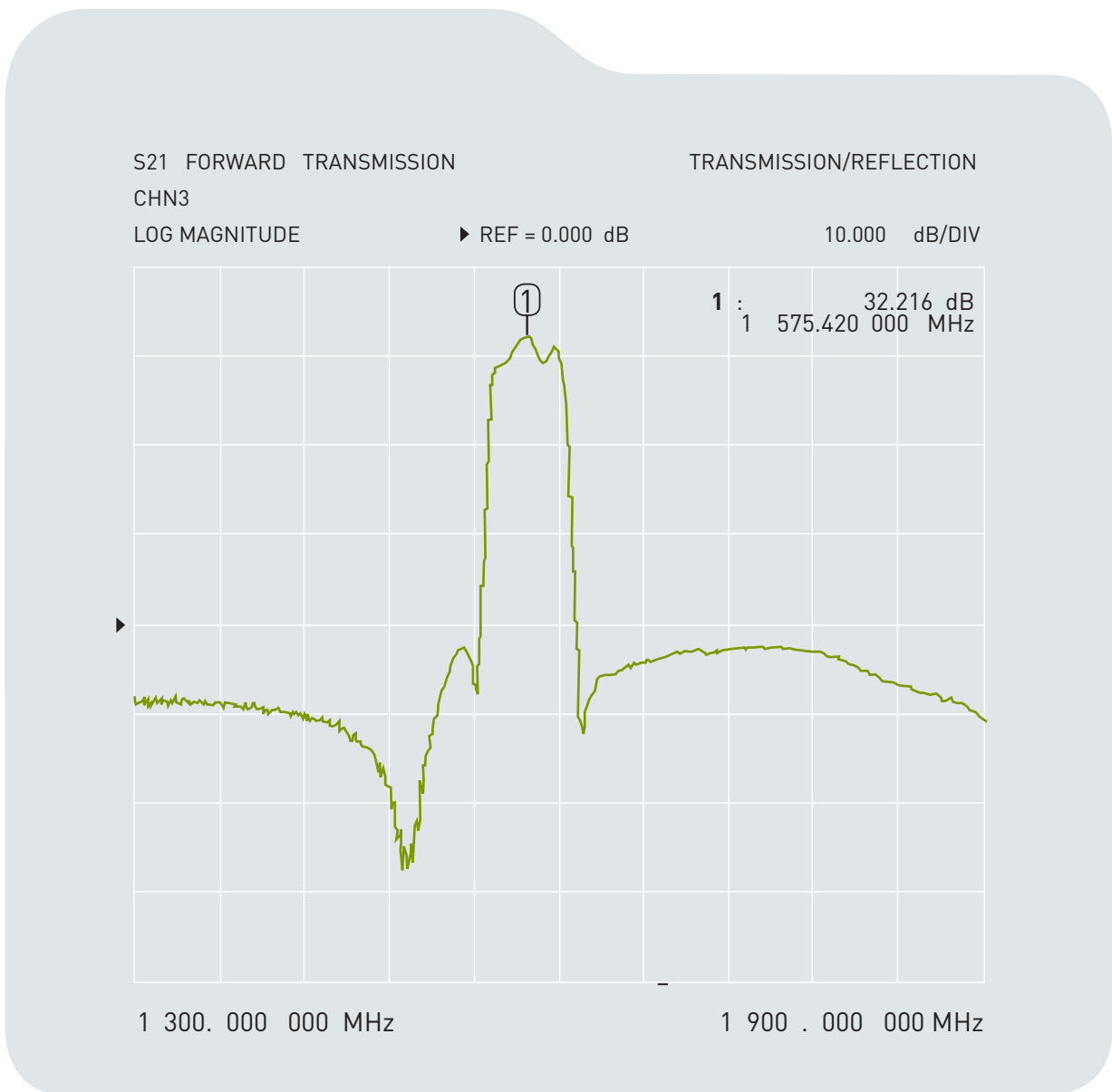

4.5 GPS Antenna Return Loss (with LNA)

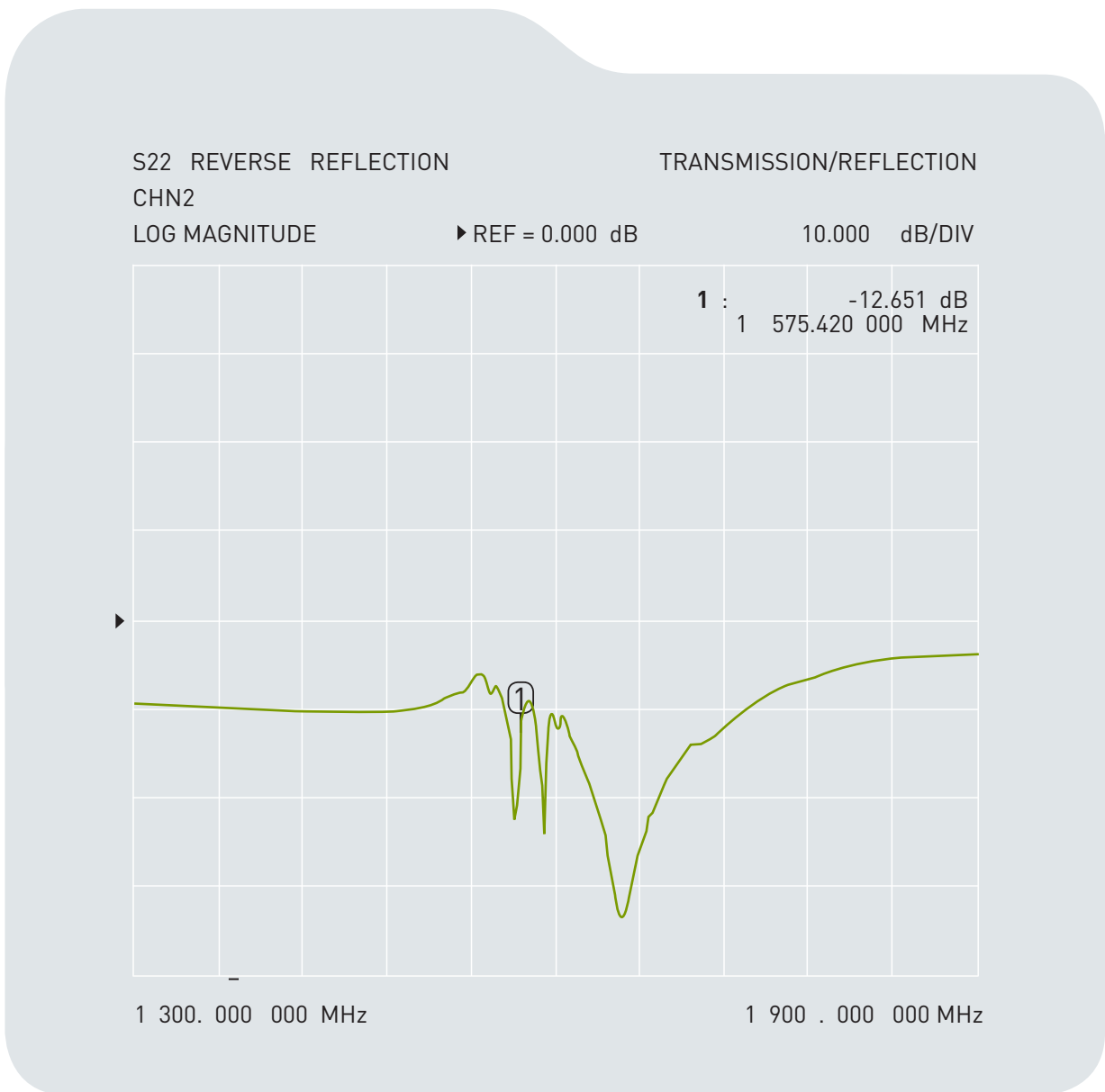

5. Cellular Antenna

5.1 Return loss (with 1M RG-174 cable)

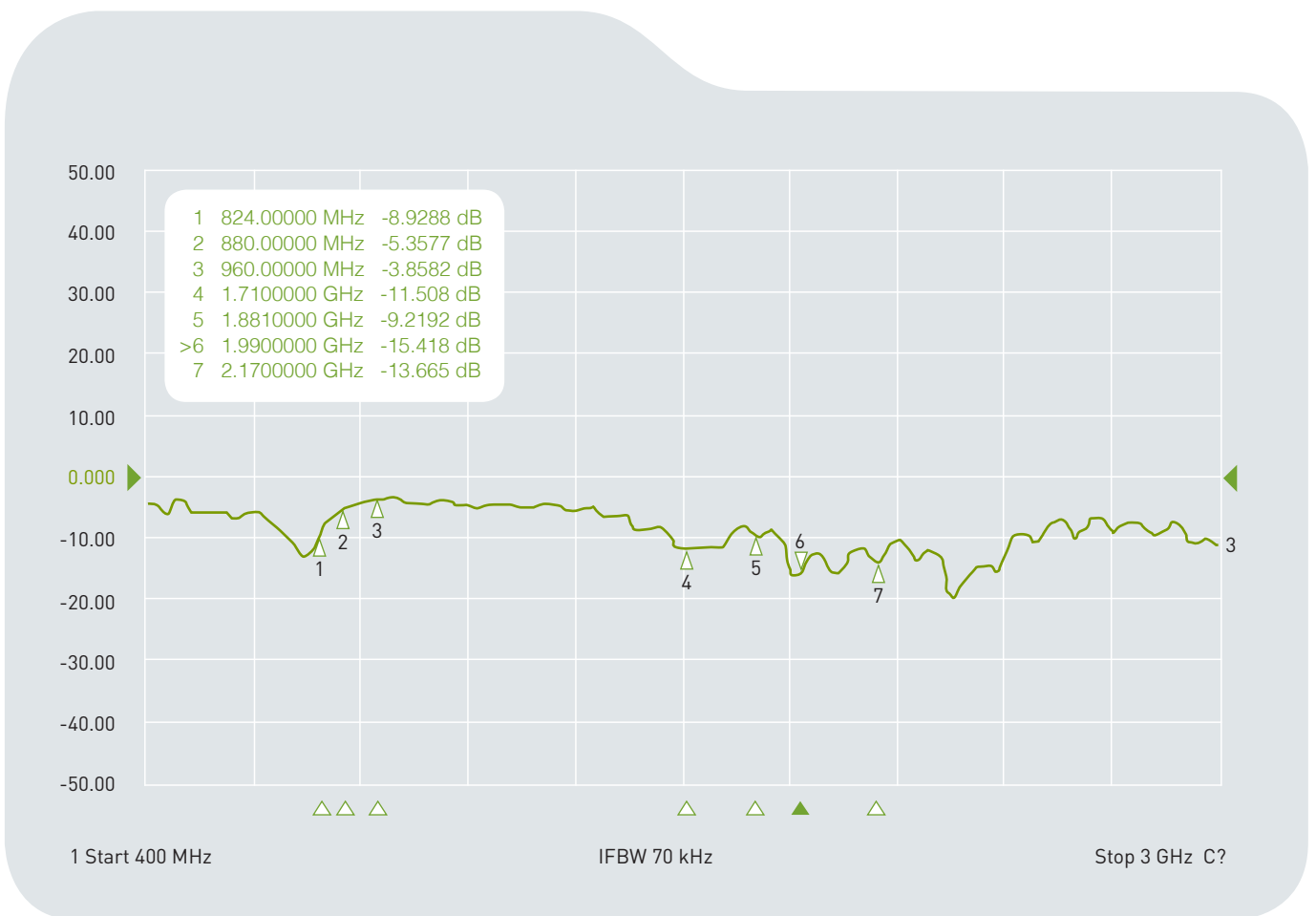

5.2 Radiation Pattern

5.2.1 XZ Plane

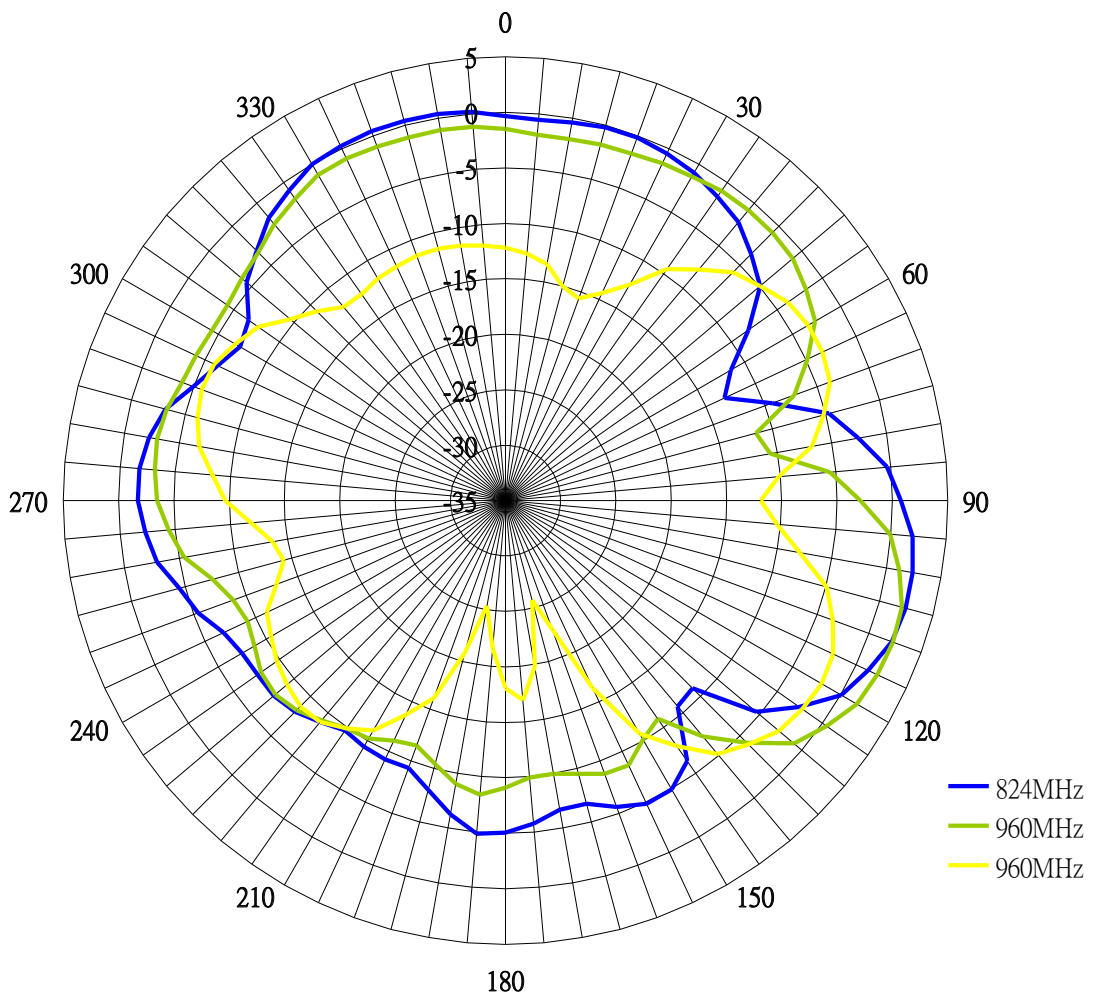

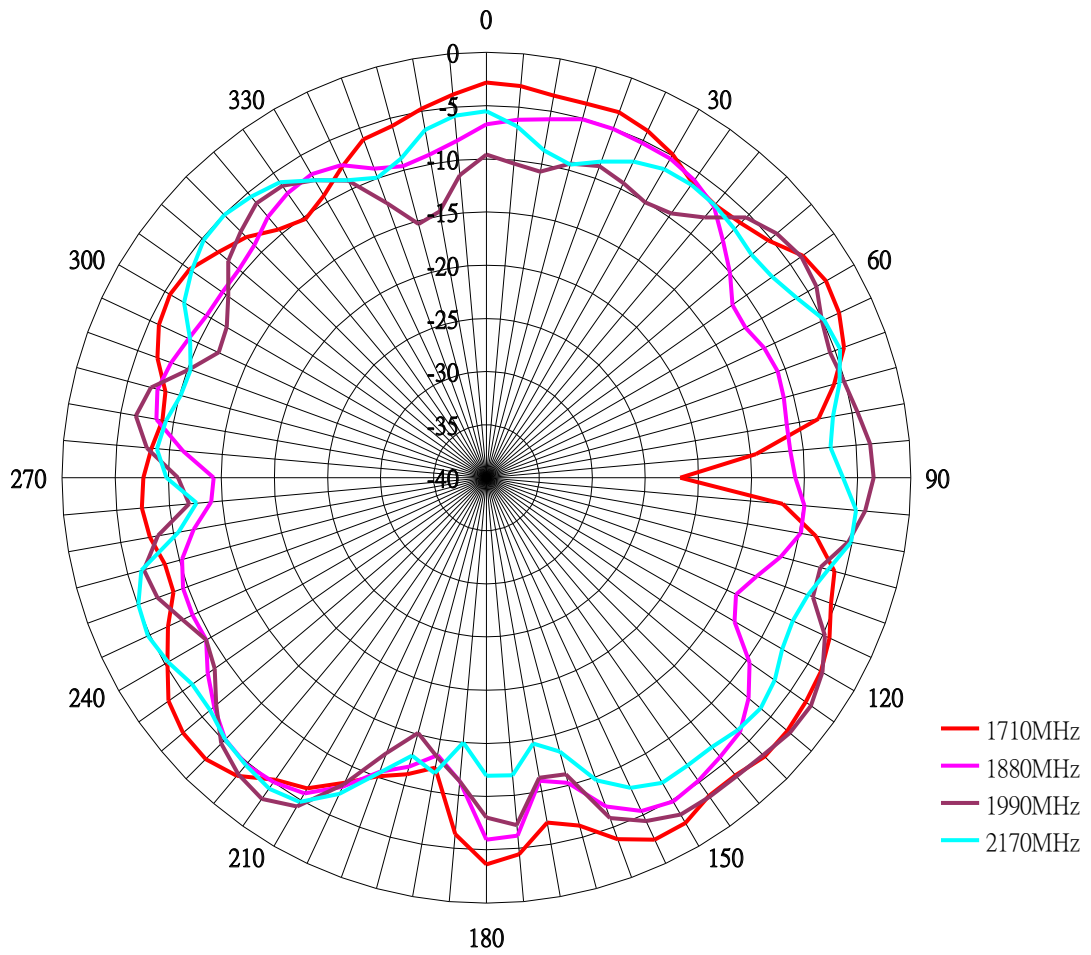

5.2.2 YZ Plane

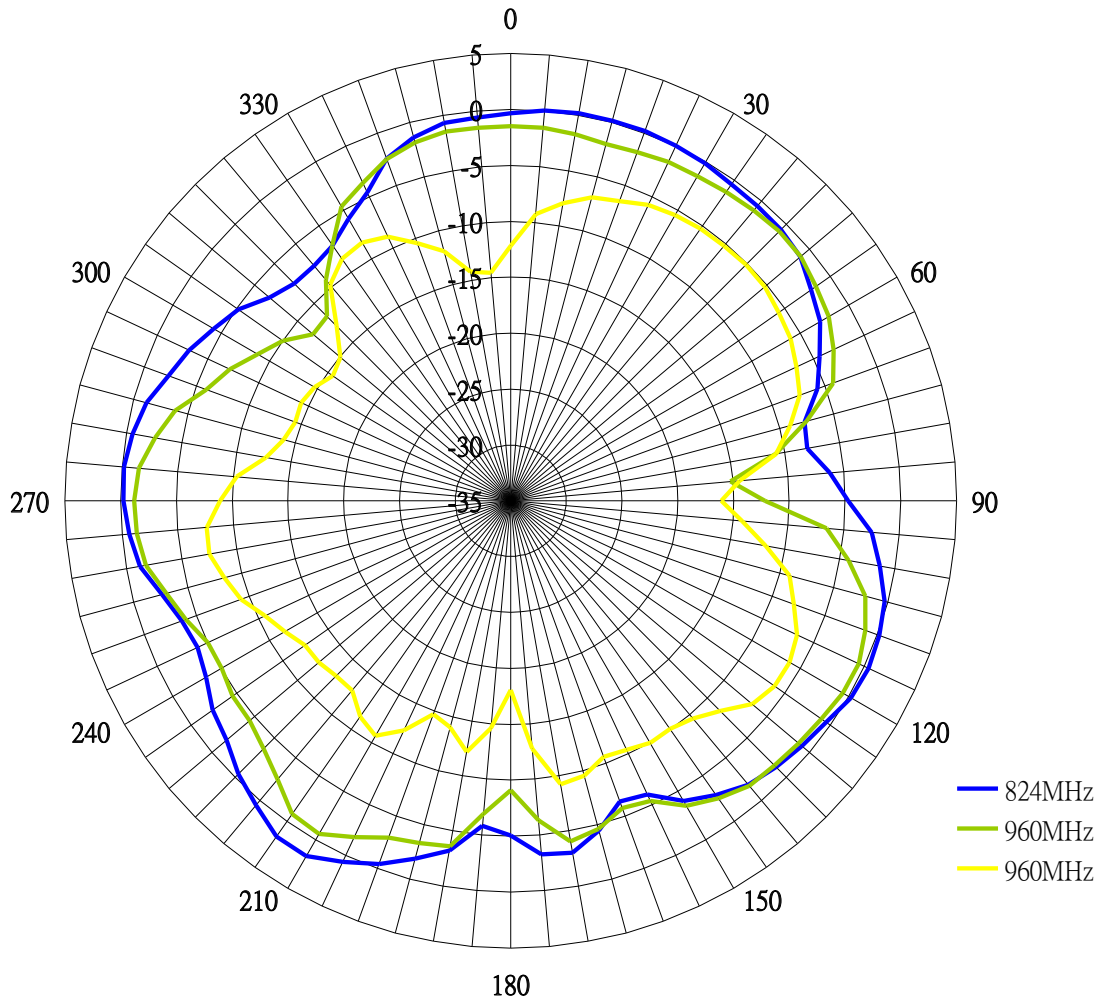

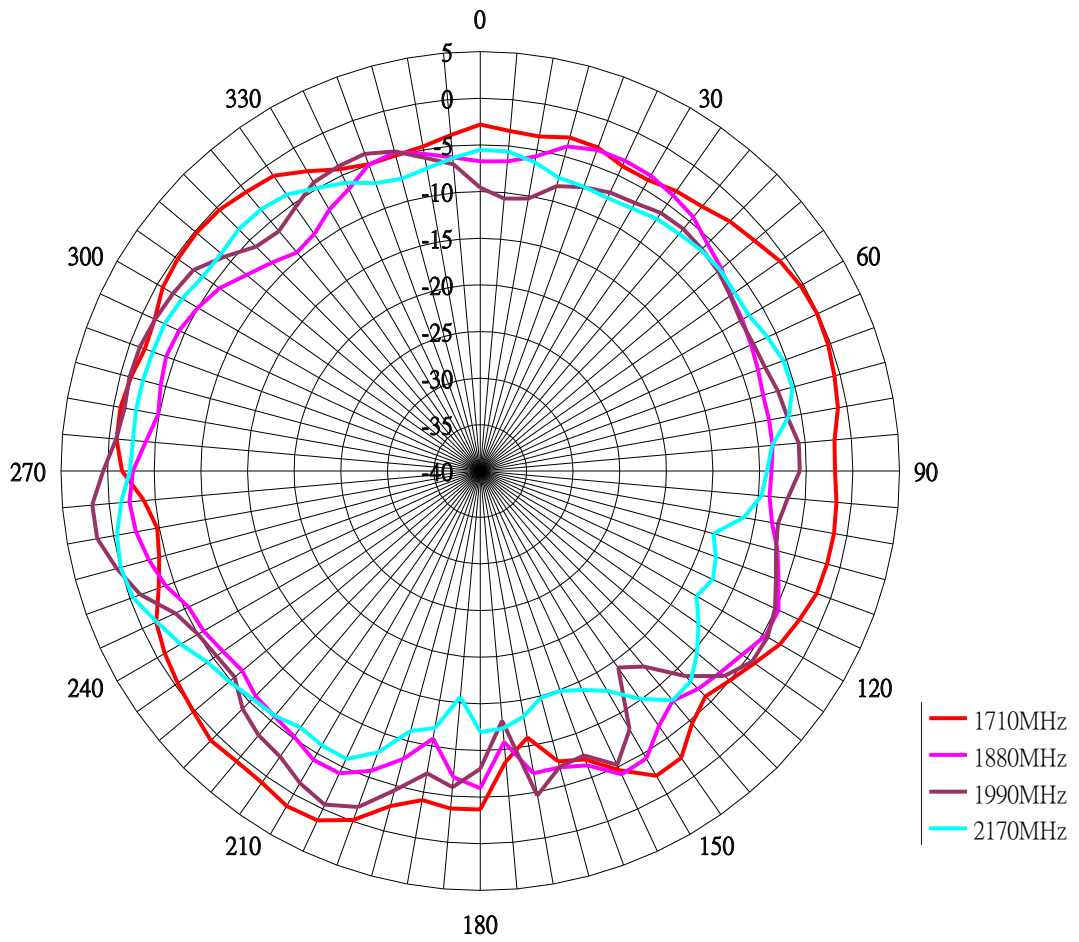

5.2.3 XY Plane

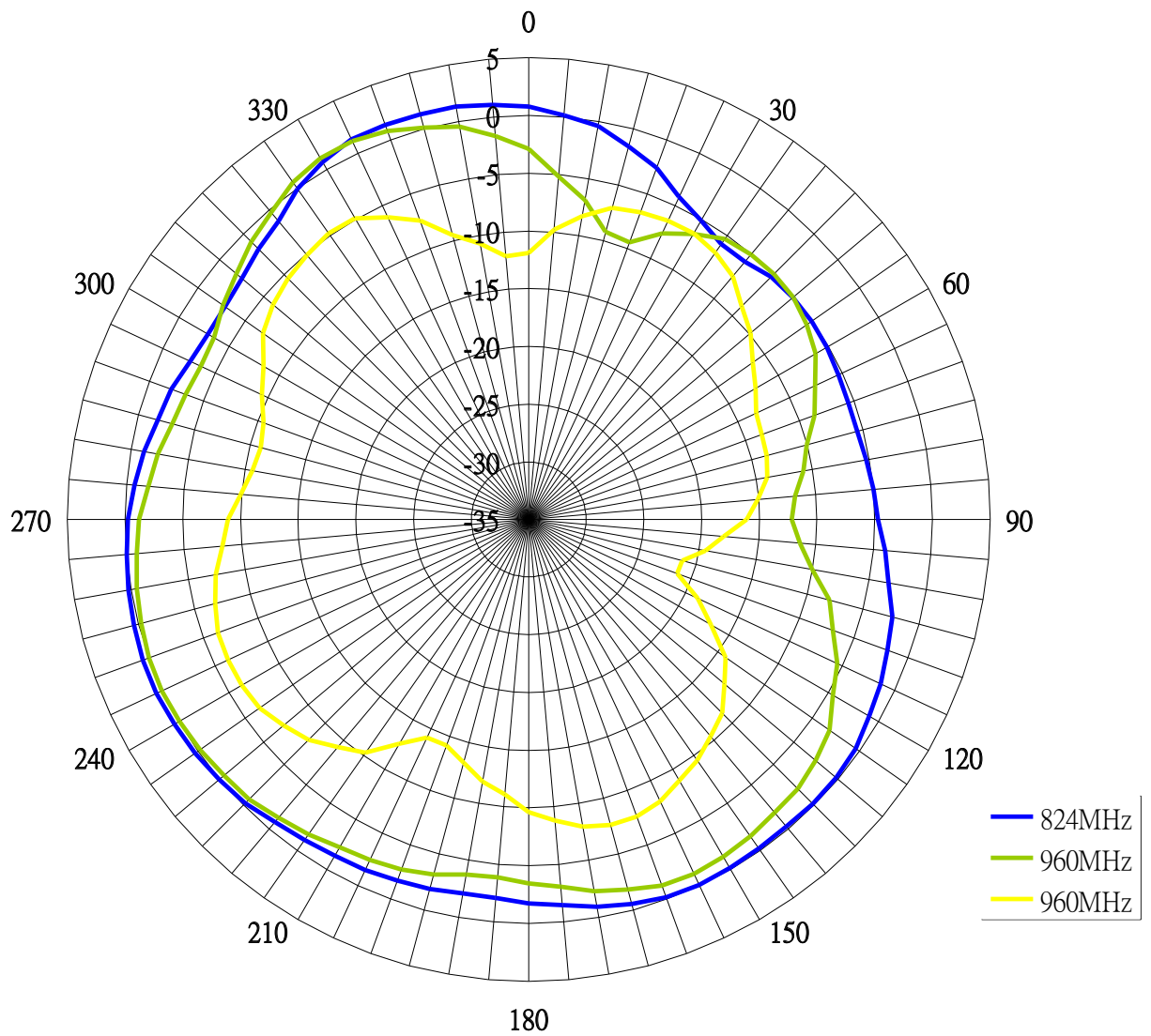

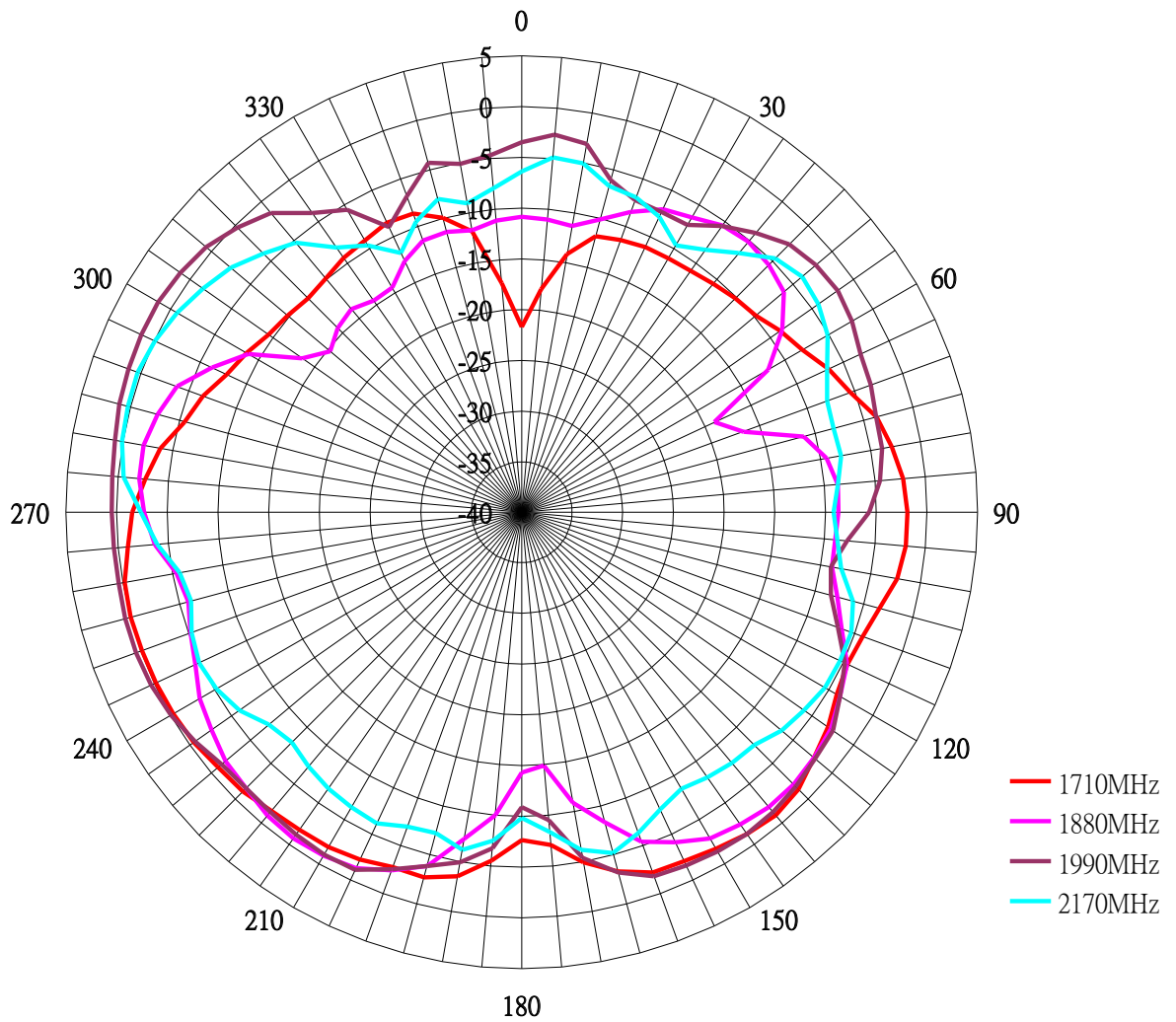

6. Mechanical Drawings

6.1 Unit

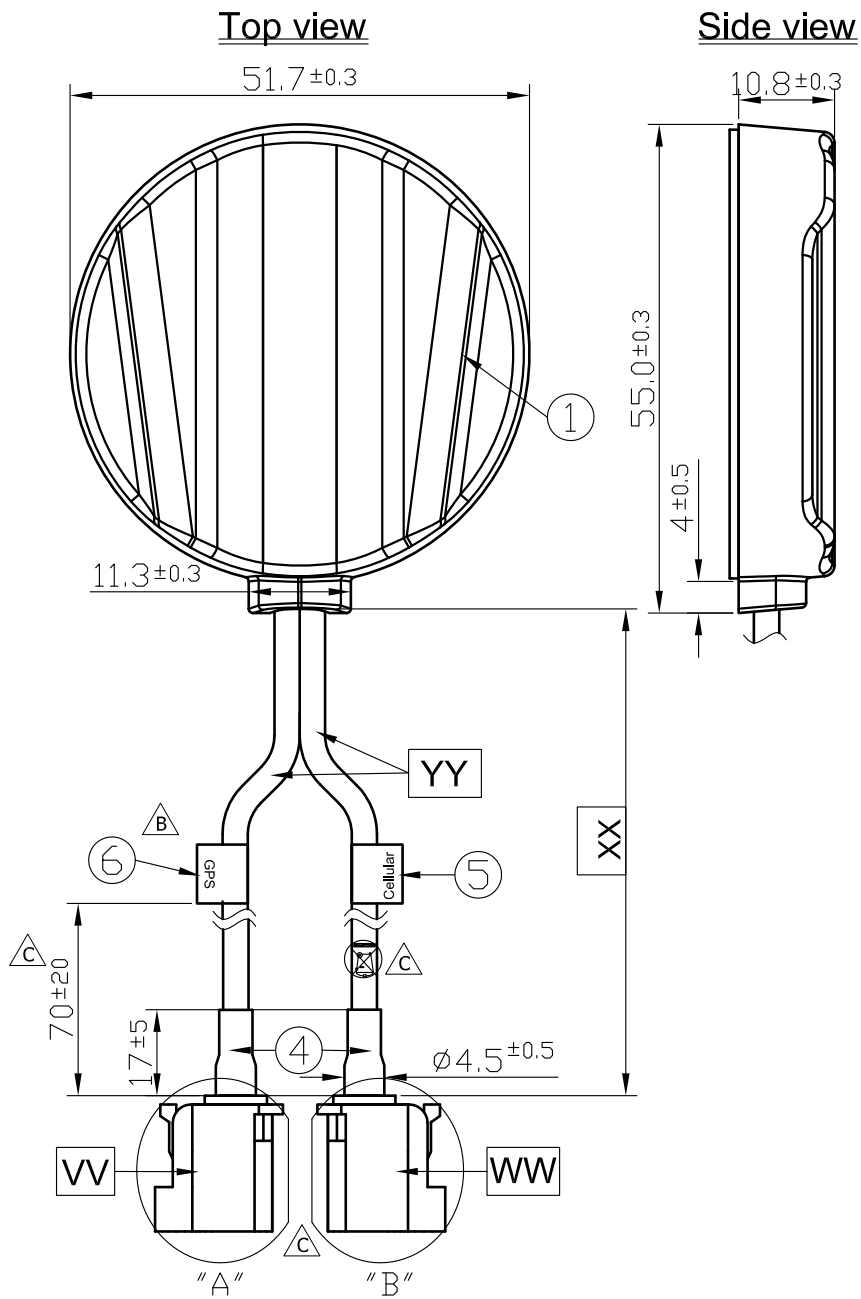

6. Mechanical Drawings

6.1 Unit



FAKRA .G2.SMB.F.ST.C.B.AM

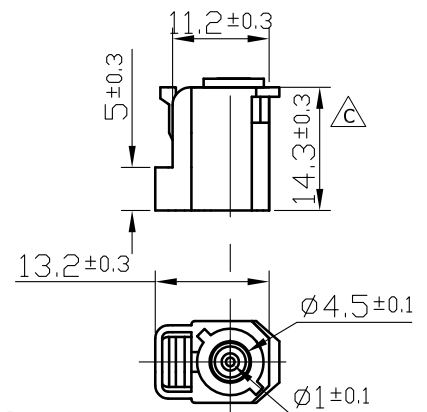

DETAIL : "A"
SCALE: 1/1

FAKRA.G2.SMB.F.ST.D.V.AM

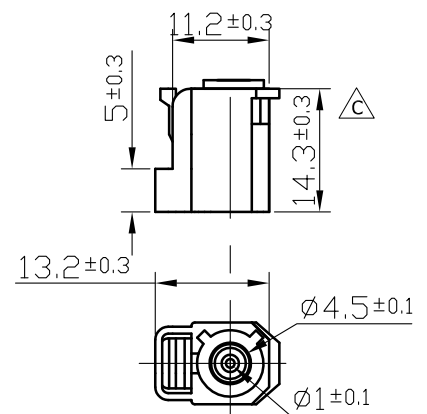

DETAIL : "B"
SCALE: 1/1

	Name	Material	Finish	QTY
1	Housing	ABS	Black	1
2	Round Label	Art Paper	White	1
3	Scotch Brand Acrylic Foam Tape	3M 4612	White Liner	1
4	Heat Shrink Tube	PE	Black	2
5	Cellular Label	Coated Paper	Blue	1
6	GPS Label	Coated Paper	Orange	1

	Name	Spec	Finish	QTY
VV	Connector Type	FAKRA Code C GEN2	Blue	1
WW	Connector Type	FAKRA Code D GEN2	Violet	1
XX	Cable Length	3000mm ± 30mm	Black	1
YY	Cable Type	RG174	Black	2

7. Packaging

1pcs antenna per small PE bag

80 small PE bag per box

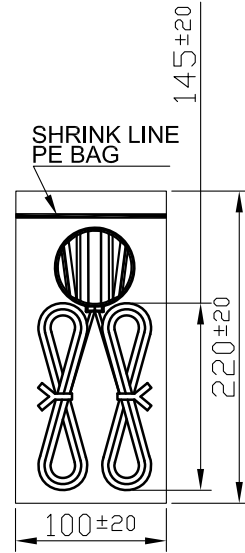

PACKING:1PCS/BAG

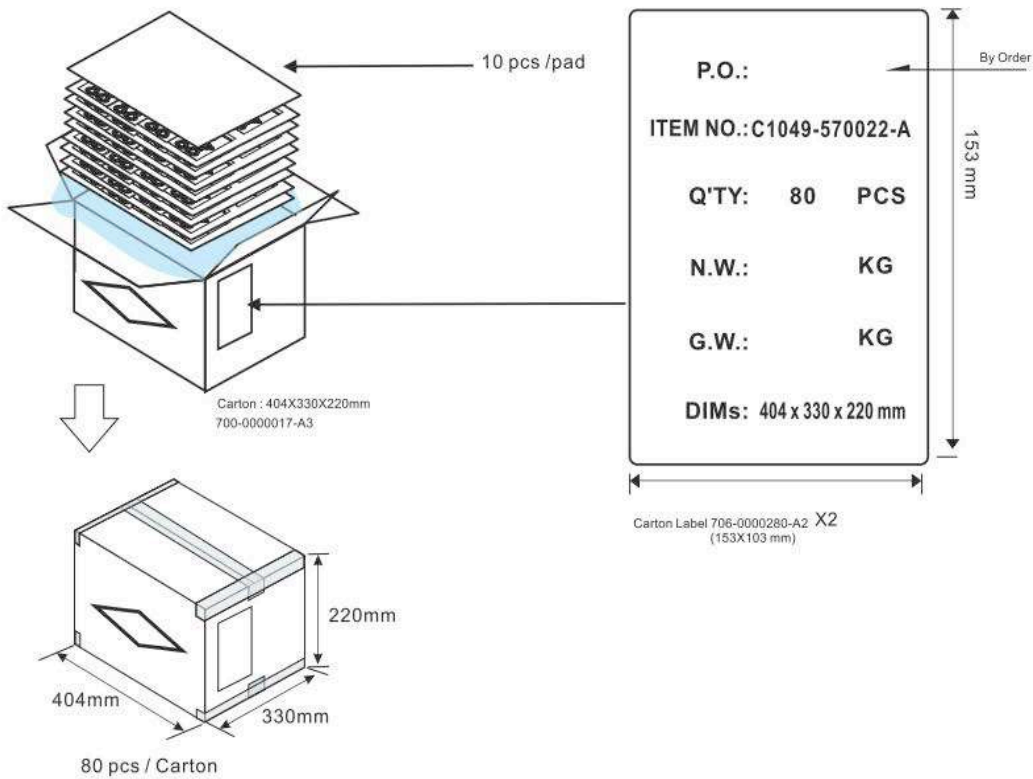

Taoglas makes no warranties based on the accuracy or completeness of the contents of this document and reserves the right to make changes to specifications and

product descriptions at any time without notice.

Taoglas reserves all rights to this document and the information contained herein.

Reproduction, use or disclosure to third parties without express permission is strictly prohibited.

Copyright © Taoglas Ltd.