

SPECIFICATION

Part No.	:	WLP.2450.25.4.A.02
Product Name	:	2450MHz Patch Antenna
Features	:	25mm*25mm*4.5mm ROHS Compliant
Photo	:	



1. Introduction

This WLP.25 patch antenna for ISM, Wi-Fi, Bluetooth and Zigbee is based on smart *XtremeGain*™ technology. It is mounted via pin and double-sided adhesive and has been selected as optimal solution for the 50*50mm ground plane. This passive patch offers typical gain response from 2.5 dBi and a higher gain can be achieved, depending on the Ground Plane, the space available and clearance afforded. The WLP.25's high gain performance is a perfect solution for metering and remote monitoring applications; it can deliver longer range than smaller chip antennas.

2. Key Antenna Performance Indicators

Original Patch Specification tested on 50*50mm ground plane

No	Parameter	Specification	Notes
1	Center Frequency	2482MHz	with 50*50mm GND Plane
2	Bandwidth	85 MHz min	Return Loss ≤-10dB
3	VSWR	2.0 max	Center Frequency
4	Gain at Zenith	+5.0dBic typ.	Center Frequency
5	Gain at 10° Elevation	-1.0dBic typ.	Center Frequency
6	Axial Ratio	3 dB Max	Center Frequency
7	Polarization	RHCP	
8	Impedance	50Ω	
9	Frequency Temp Coefficient (Tf)	0±20ppm/°C	-40°C to +105°C
10	Operating Temperature	-40°C to +105°C	

***Changes in user groundplane and environment will have an effect on the antennas performance**

3. Mechanical Specifications

3.1 Dimensions and Drawing

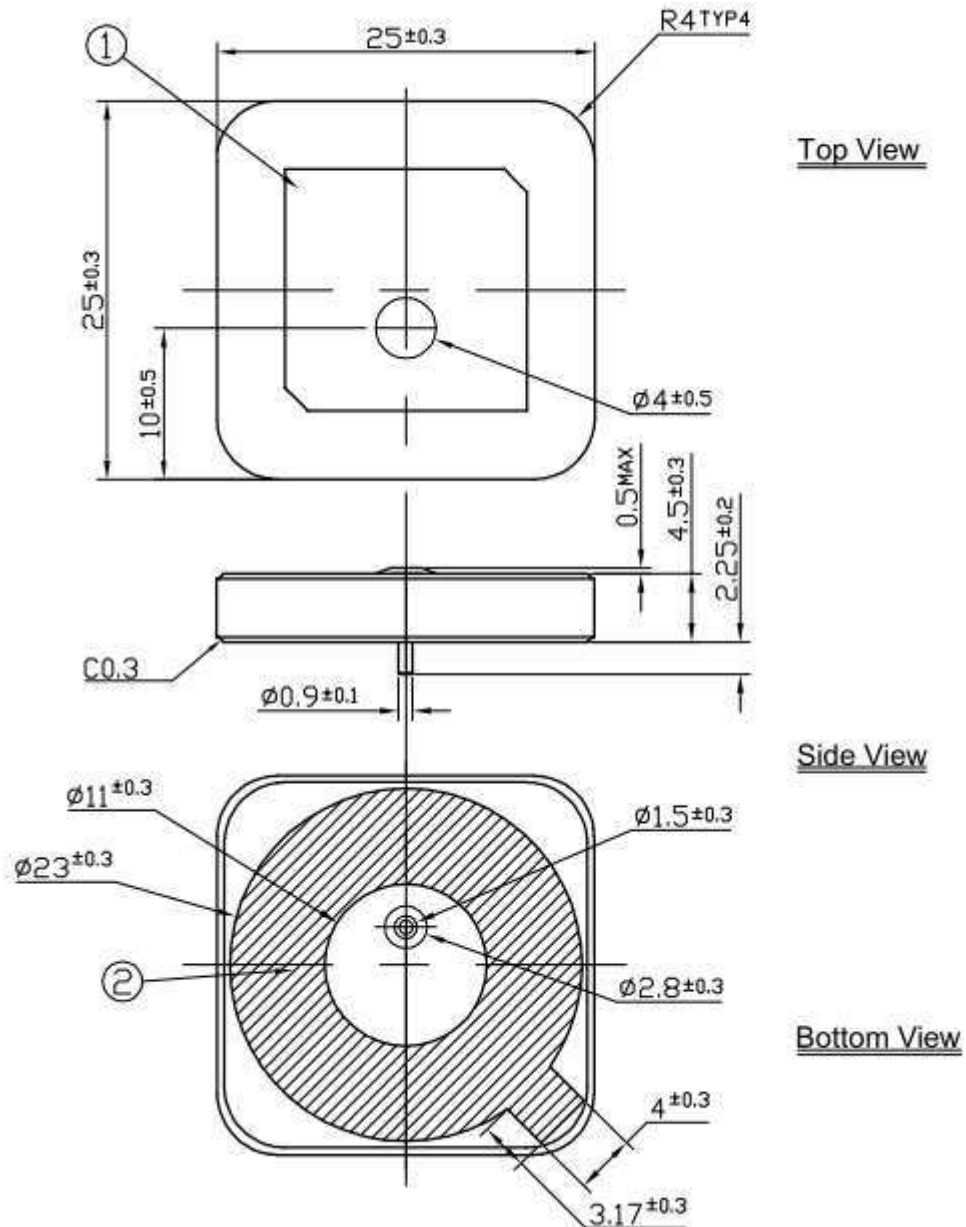

	Name	Material	Finish	QTY
1	WLP.2450 Patch 25x25x4	Ceramic	Clear	1
2	Double Sided Adhesive	NITTO 5015	White Liner	1

NOTE:
1. Double Sided Adhesive 

3.2 Layout Dimensions

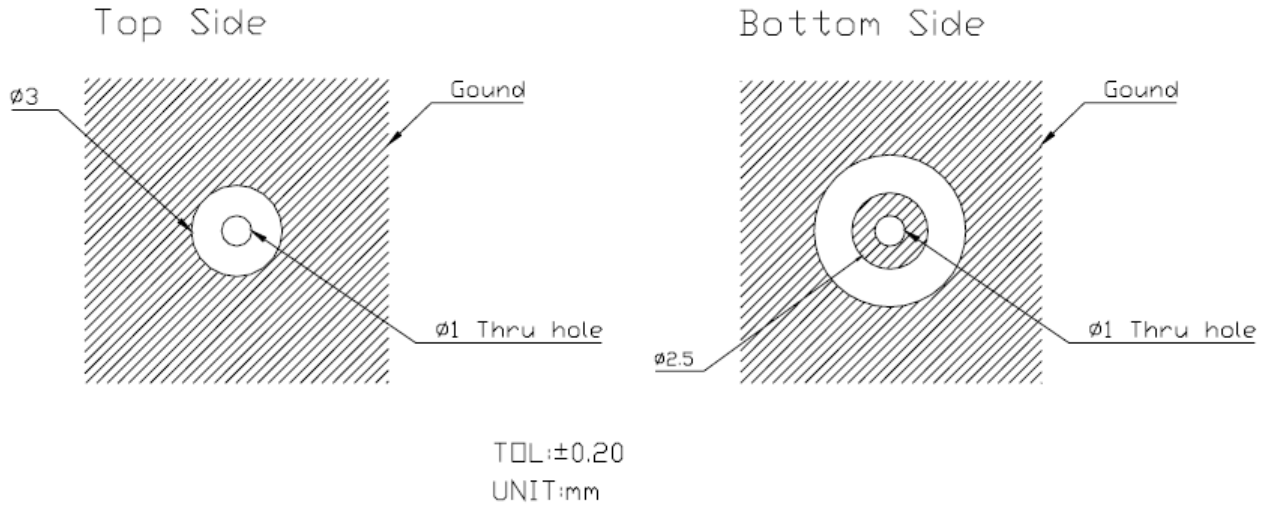

3.3 Ground Plane Dimension

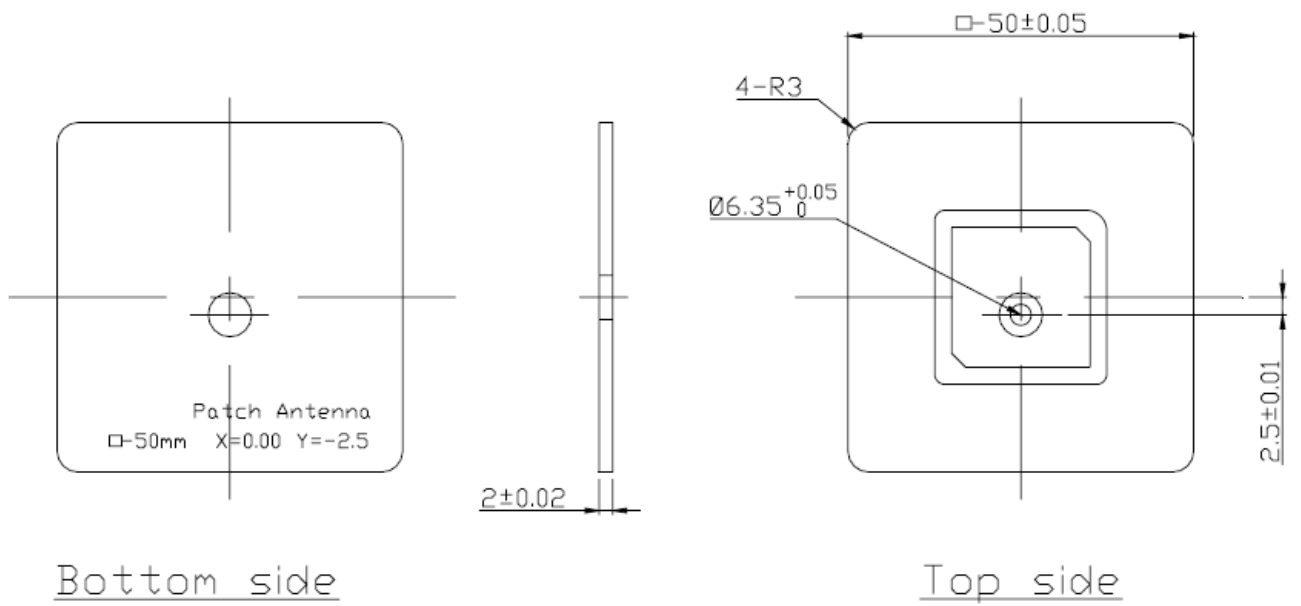

3.4 Test Fixture Antenna & Performance Measurements

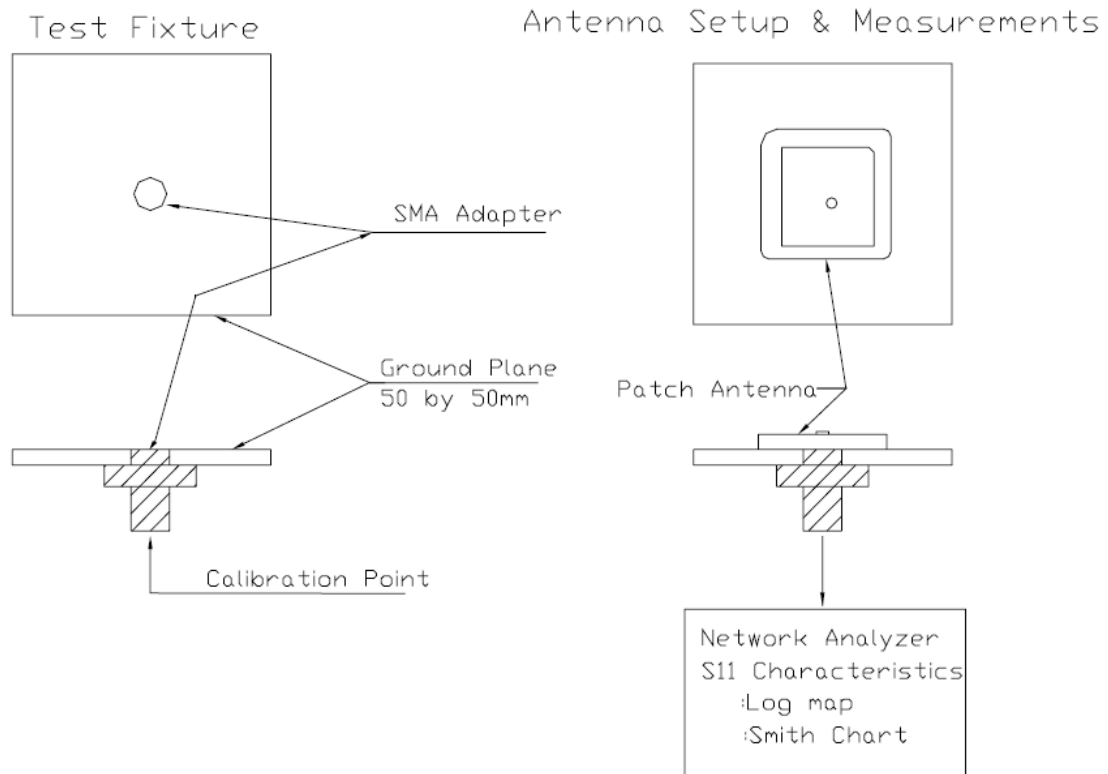

4. Performance Measurement

4.1 Antenna S11(Return Loss)

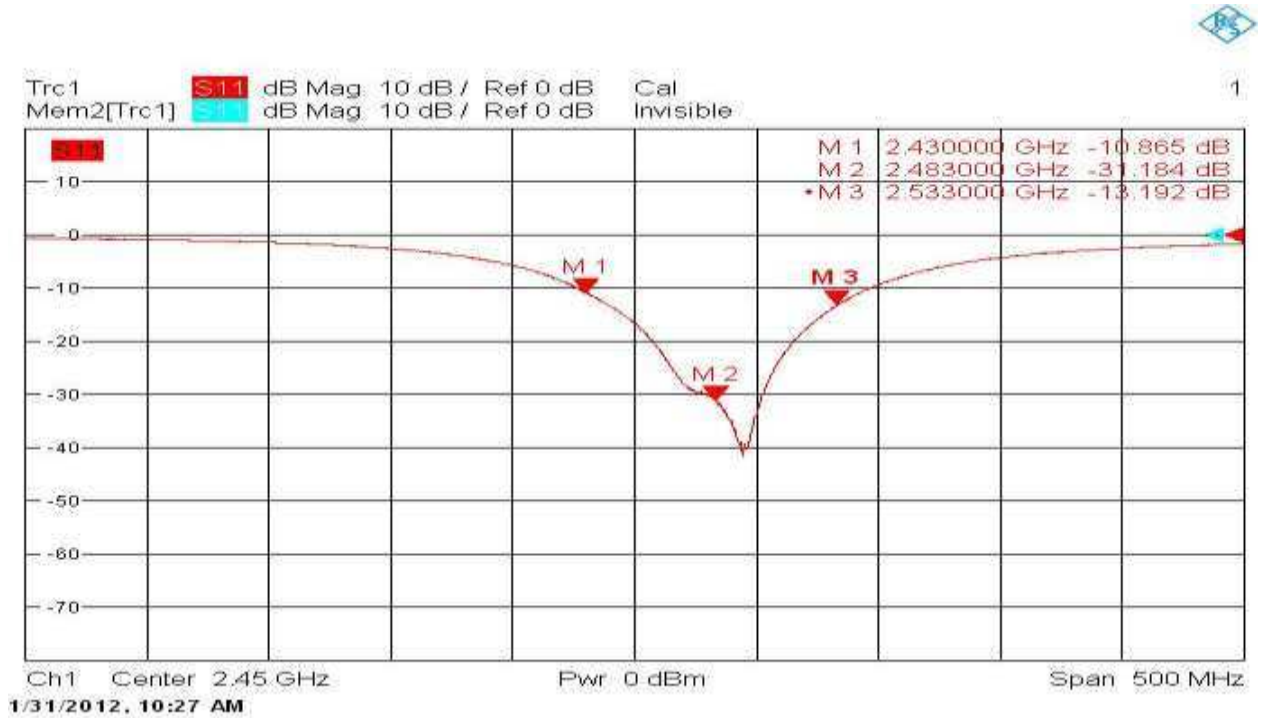

4.2 VSWR

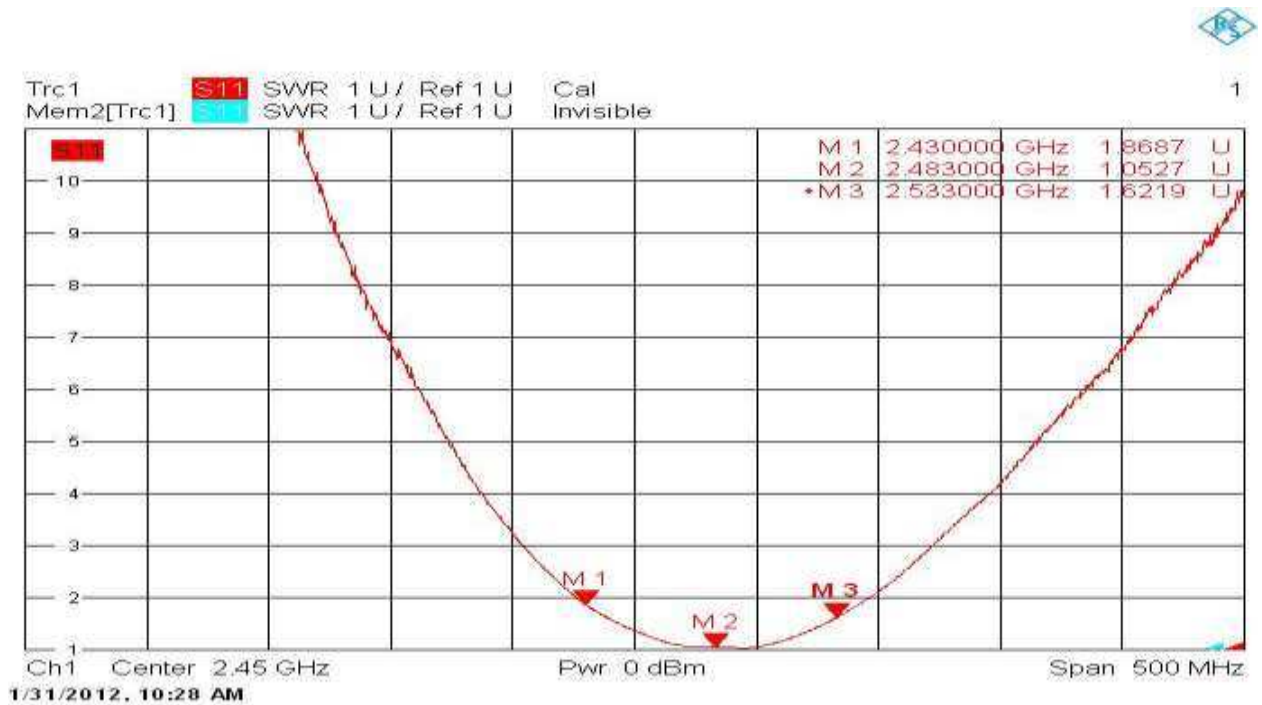

4.3 Antenna Smith Chart (Impedance)



Trc1 S11 Smith Ref 1 U Cal
 Mem2[Trc1] S11 Smith Ref 1 U Invisible

1

S11

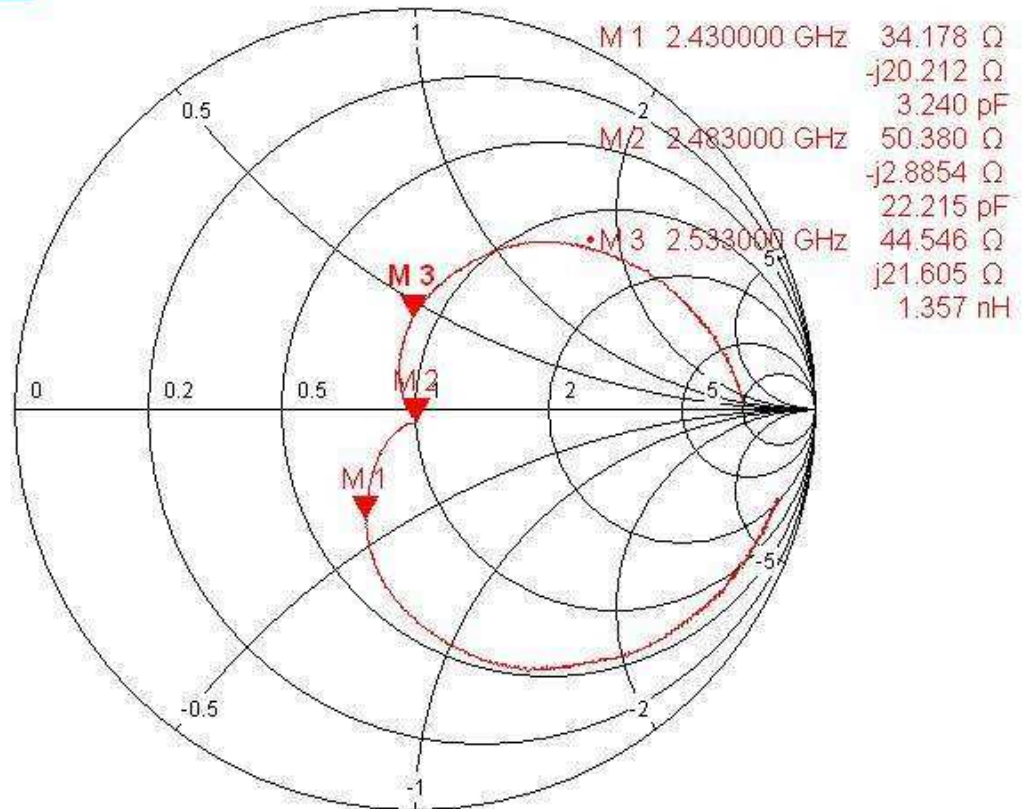

Ch1 Center 2.45 GHz
 1/31/2012, 10:27 AM

Pwr 0 dBm

Span 500 MHz

4.4 Efficiency

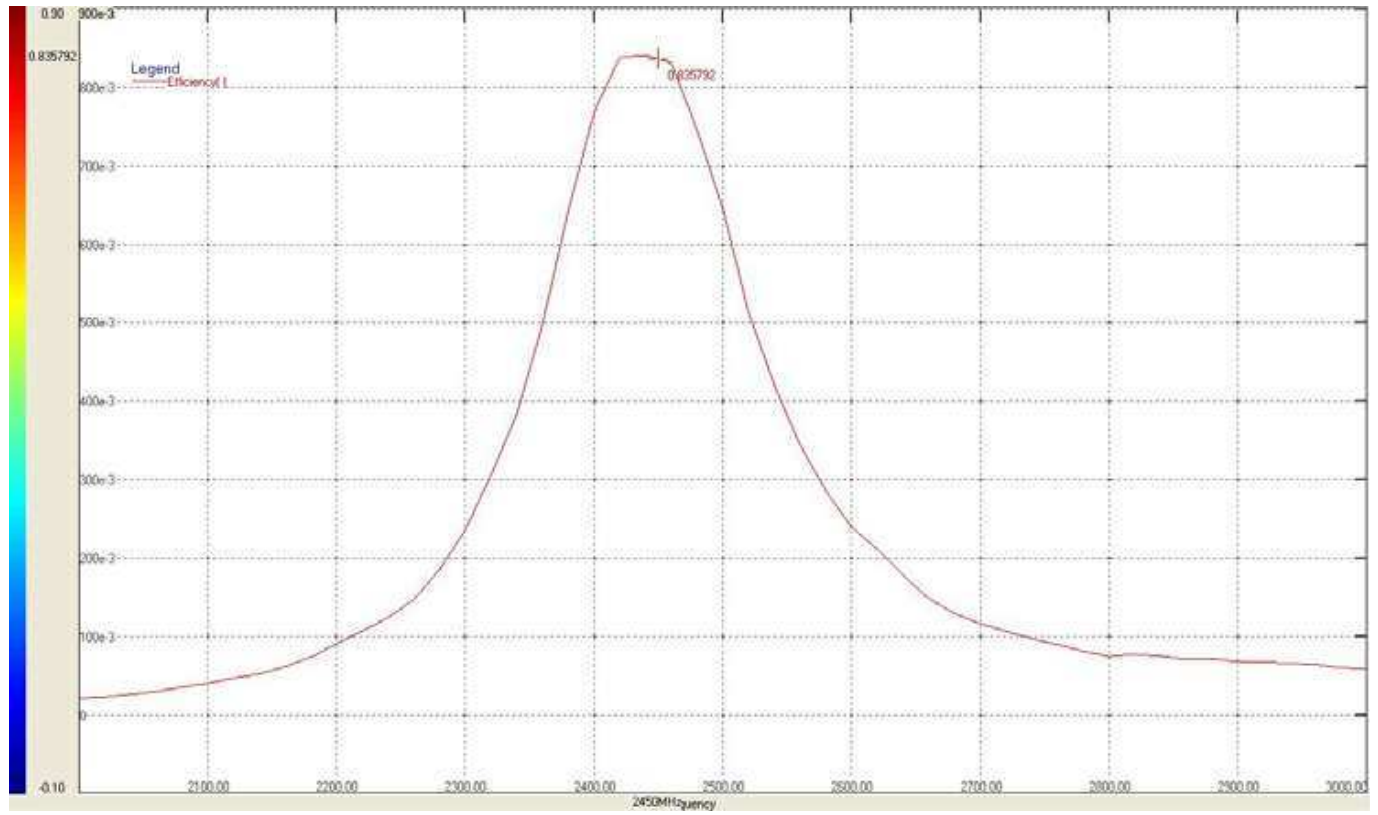

4.5 Antenna Gain

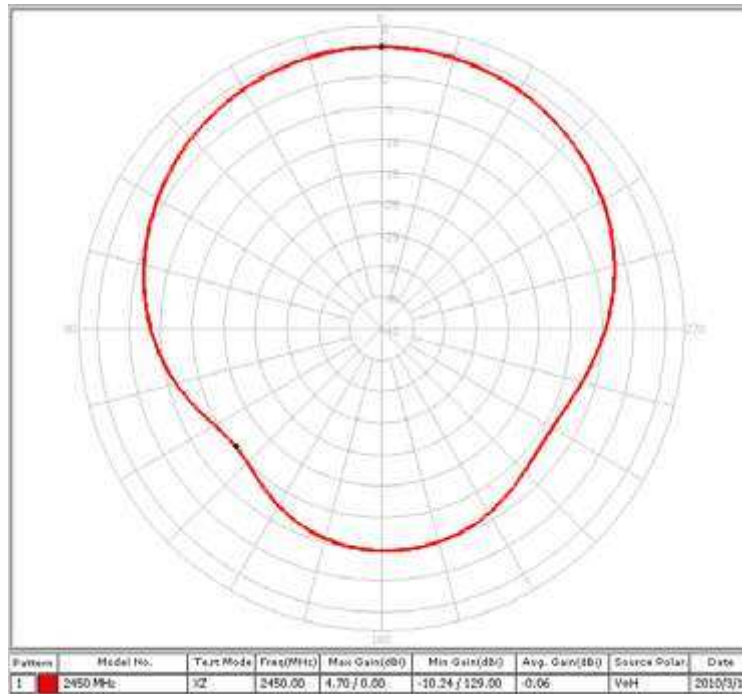

XZ-Plane

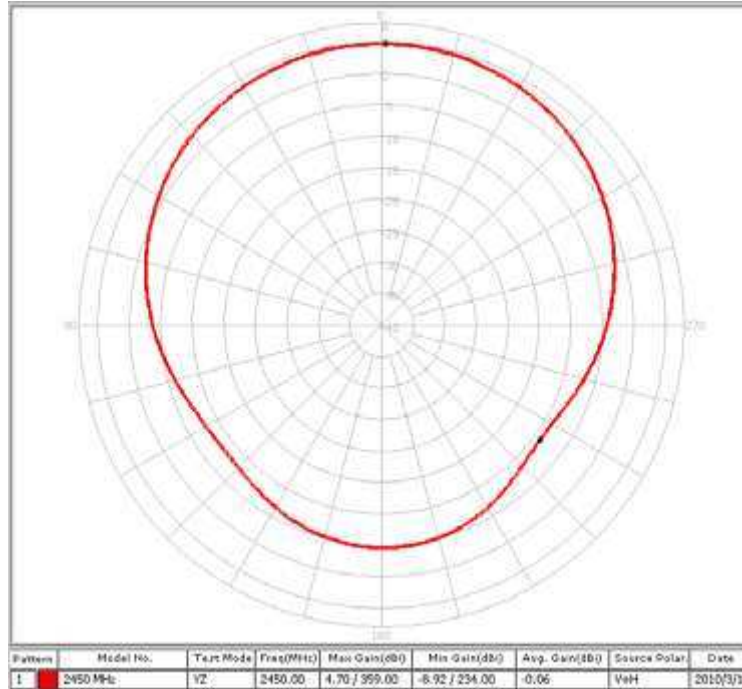

YZ-Plane

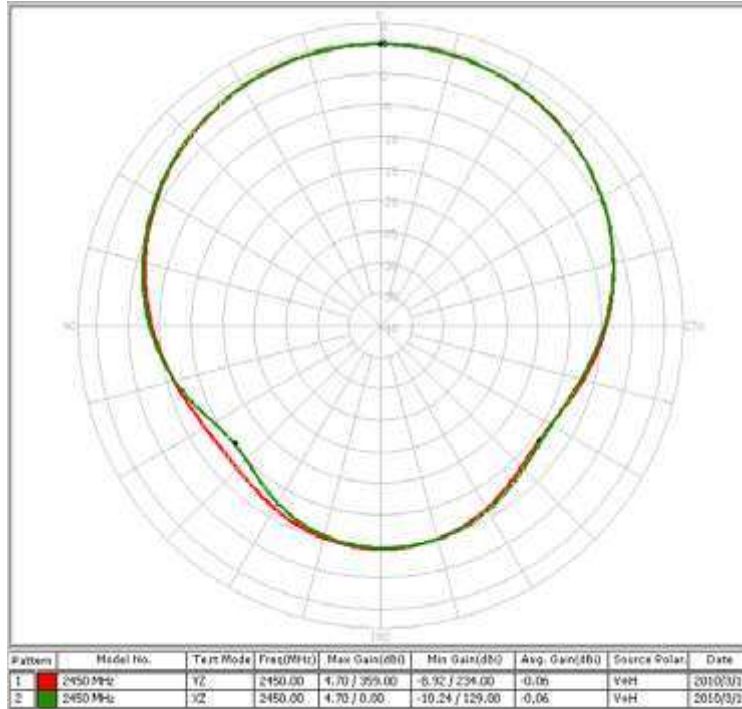

XY Plane

5. Packaging

- Per Tray: 50 pieces
- Per Carton(Inside Box) – 4 Trays = 200 pieces
- Outer Carton (Outside Box)- 4 Cartons = 800 pieces

