

PART NO.	"A"±.015 (±0.4)	"B"±.015 (±0.4)	"C"±.015 (±0.4)	HOLE DIA. ±.003 (±0.08)	PANEL THICKNESS
BHL-3-01	3/16 (4.8)	7/16 (11.1)	5/16 (7.9)	.312 (7.92)	1/4 (6.4) MIN.
BHL-4-01	1/4 (6.4)				
BHL-6-01	3/8 (9.5)				
BHL-7-01	7/16 (11.1)				
BHL-8-01	1/2 (12.7)				
BHL-10-01	5/8 (15.9)				
BHL-12-01	3/4 (19.1)				
BHL-14-01	7/8 (22.2)				
*BHL1-3-01	3/16 (4.8)	3/8 (9.5)	17/64 (6.7)	.250 (6.35)	1/4 (6.4) MIN.
*BHL1-4-01	1/4 (6.4)				
*BHL1-6-01	3/8 (9.5)				
*BHL1-7-01	7/16 (11.1)				
*BHL1-8-01	1/2 (12.7)				
*BHL1-10-01	5/8 (15.9)				
*BHL1-12-01	3/4 (19.1)				
*BHL1-14-01	7/8 (22.2)				

*PART AVAILABLE BY SPECIAL ORDER ONLY

TO SNAP LOCK IN .156±.003
(4.00±0.08) DIA. HOLE IN A
.062 (1.57) THICK BOARD.

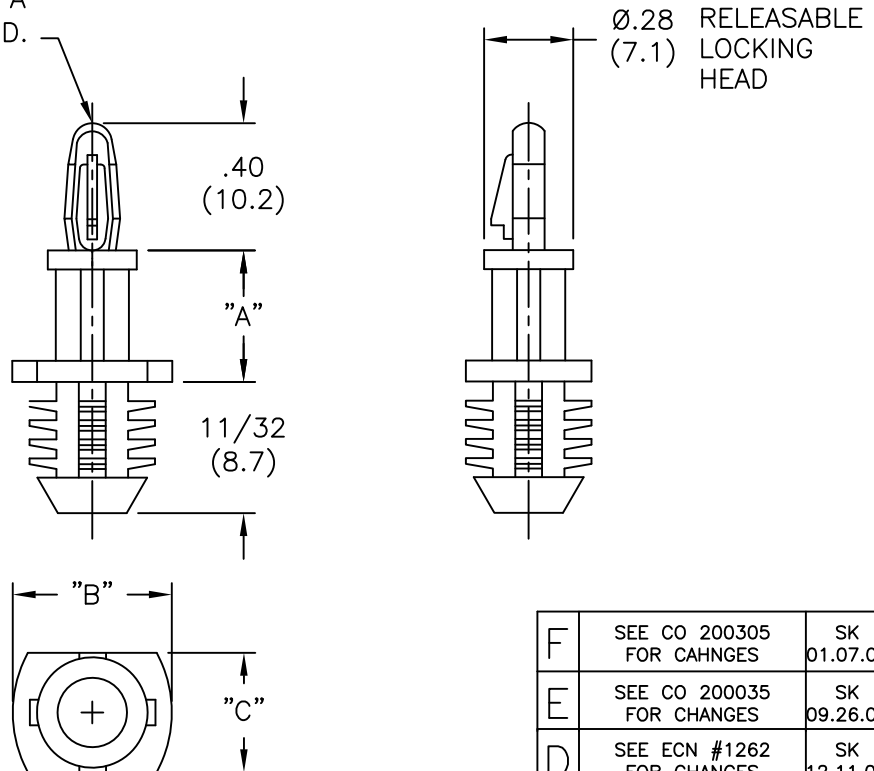

NOTES:

- MATERIAL: NYLON 6/6 UL 94 V-2 (RMS-01).
-NYLON 6/6 UL 94 V-0 (RMS-19),
AVAILABLE BY SPECIAL ORDER ONLY.
-UV STABILIZED NYLON 6/6 (RMS-46), COLOR BLACK,
AVAILABLE BY SPECIAL ORDER ONLY.
TO ORDER, REPLACE "-01" WITH "-UVB".
- COLOR: NATURAL.

F	SEE CO 200305 FOR CHANGES	SK 01.07.09
E	SEE CO 200035 FOR CHANGES	SK 09.26.07
D	SEE ECN #1262 FOR CHANGES	SK 12.11.06
C	ADDED P/N'S BHL1-... & CHANGED FILE NO.	S.M. 08.10.01
B	MAT'L RMS-19 ADDED	J.L. 12.18.97
A	GIVEN NEW FILE NUMBER	JB 08.31.95
REV	DESCRIPTION	ENGR DATE

TITLE: BLIND HOLE LOCKING CKT. BD. SUPPORT (BHL)



TOLERANCES UNLESS NOTED .XX±.010 .XXX±.005 FRAC=±1/64 ANG=±1'	FILE # BHL	DWN: R.S	APP:	FINAL	
	MAT'L: SEE NOTES	DT: 10-08-93	DT:	PART #	PRINT
RE: RICHCO, INC.	RICHCO INC. PO BOX 804238, CHICAGO, 60680 (773) 539-4060			SEE TABLE	TYPE CA