

PART #	ASSEMBLED THICKNESS "T"	"A" REF.	"B" ±.010 (±0.25)	"C" ±.010 (±0.25)
BR1-226-01	.235-.297(6.0-7.5)	.226(5.7)	.750(19.1)	.093(2.4)
BR1-344-01	.346-.502(8.8-12.8)	.344(8.7)		
BR1-488-01	.500-.812(12.7-20.6)	.488(12.4)		
BR1-768-01	.781-1.375(19.8-34.9)	.768(19.5)		
BR2-226-01	.235-.297(6.0-7.5)	.226(5.7)	.406(10.3)	.062(1.6)
BR2-344-01	.346-.502(8.8-12.8)	.344(8.7)		
BR2-488-01	.500-.812(12.7-20.6)	.488(12.4)		
BR2-768-01	.781-1.375(19.8-34.9)	.768(19.5)		

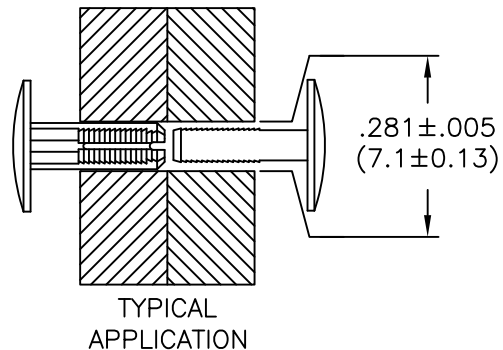
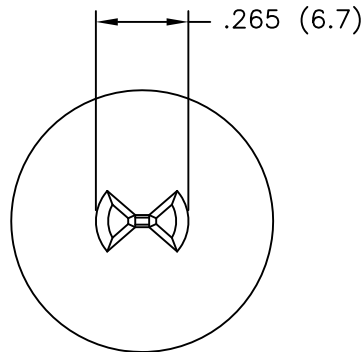
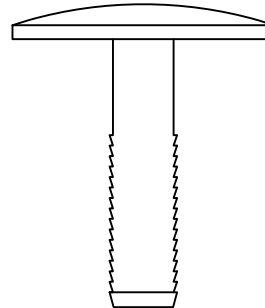
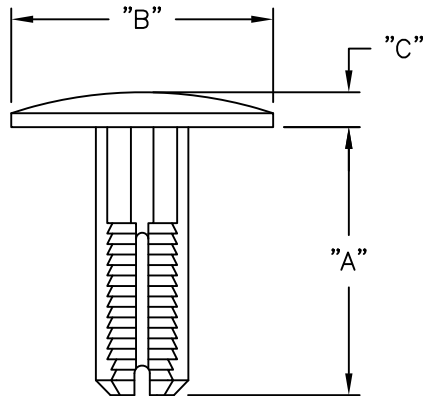

NOTES:

1. MOUNTING HOLE DIA.  $.281 \pm .005$  (7.1 ± 0.13).
2. MATERIAL: NYLON 6/6 UL 94 V-2 (RMS-01).  
COLOR: NATURAL. BLACK IS AVAILABLE BY SPECIAL ORDER.  
TO ORDER ADD "BK" TO PART NO.  
NYLON 6/6 UL 94 V-0 (RMS-19)  
AVAILABLE BY SPECIAL ORDER ONLY.
3. AVAILABLE IN CLEAR PROPIONATE (RMS-12) UPON REQUEST.

E	SEE CO 200589 FOR CHANGES	SK 10.20.10
D	SEE ECN #1265 FOR CHANGES	SK 12.12.06
C	SEE ECN #715 FOR CHANGES	SM 10.09.03
B	CHANGED FILE NUMBER	SM 05.24.01
A	CHANGED DIMENSIONS	MH 09.04.97
REV	DESCRIPTION	ENGR DATE

TITLE: BARBED RIVET



DWG IN IN(MM)  
FINAL

TOLERANCES UNLESS NOTED .XX=±.020 .XXX=±.015 FRAC=±1/64 ANG=±1'	FILE # BR MAT'L: SEE NOTES RE: RICHCO, INC.	DWN: M.H. DT: 09-04-97	APP: DT:	PART # SEE TABLE	PRINT TYPE CA
		RICHCO INC. PO BOX 804238, CHICAGO, 60680 (773) 539-4060			