

PART NO.	"A" REF.	MAX. BUNDLE DIA. "B"	TO BE USED WITH	FIGURE NO.
CAT-05-PP-BL	2.09 (53)	.24 (6)	SHR-05-YYY*	2
CAT-08-PP	2.80 (71)	.37 (9.5)	SHR-08-YYY*	1
CAT-15-PP	3.19 (81)	.63 (16)	SHR-15-YYY*	
CAT-20-PP	3.94 (100)	.79 (20)	SHR-20-YYY*	
CAT-25-PP	4.45 (113)	.96 (24.5)	SHR-25-YYY*	
CAT-32-PP	5.67 (144)	1.22 (31)	SHR-32-YYY*	

*YYY-SHR MATERIAL

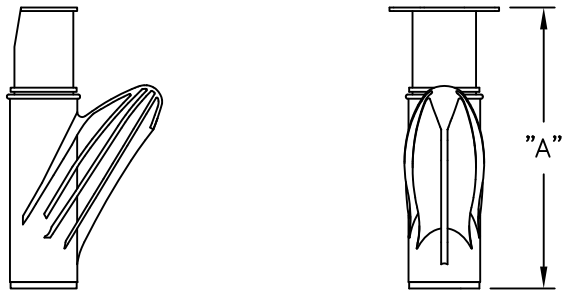
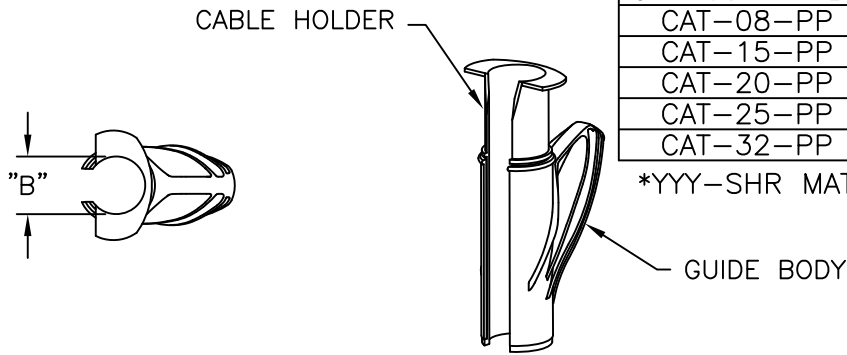

FIGURE 1.
MATERIAL: A) GUIDE BODY: -POLYPROPYLENE (RMS-268); COLOR: ORANGE.
B) CABLE HOLDER - POLYACETAL (RMS-267), COLOR: WHITE

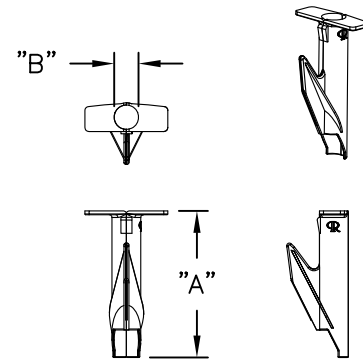

FIGURE 2.
MATERIAL: POLYPROPYLENE (RMS-150); COLOR: BLUE.

NOTES:

- FIGURE 1. TOOL AVAILABLE IN BULK PACKAGES OF 100/BOX. TO ORDER ADD "-BU" TO THE PART NO.
- CAT-20, "-25" AND "-32" AVAILABLE IN GLASS FILLED NYLON (RMS-253) FOR HEAVY DUTY APPLICATION. TO ORDER, REPLACE "-PP" WITH "-IX"; COLOR: BLUE.

TITLE: CABLE APPLICATOR TOOL			DWG IN IN (MM)		FINAL	
D	SEE CO 200297 FOR CHANGES	SK 12.16.08	FILE #	CAT	DWN: SM	APP:
C	SEE CO 200219 FOR CHANGES	SK 07.21.08	MAT'L:	SEE NOTES	DT: 03.01.02	DT:
B	SEE ECN #1319 FOR CHANGES	SK 04.19.07	RE:	RICHCO, INC.	RICHCO INC. PO BOX 804238, CHICAGO, 60680 (773) 539-4060	
A	REDRAWN FROM RICHCO UK	SM 03.01.02			PART #	PRINT TYPE
REV	DESCRIPTION	ENGR DATE			SEE TABLE	CA