

PART NO.	DIM. "A" ±.015(0.4)
CRLCBSR-3-01	3/16 (4.8)
CRLCBSR-4-01	1/4 (6.4)
CRLCBSR-5-01	5/16 (8.0)
CRLCBSR-6-01	3/8 (9.5)
CRLCBSR-8-01	1/2 (12.7)
CRLCBSR-12-01	3/4 (19.0)

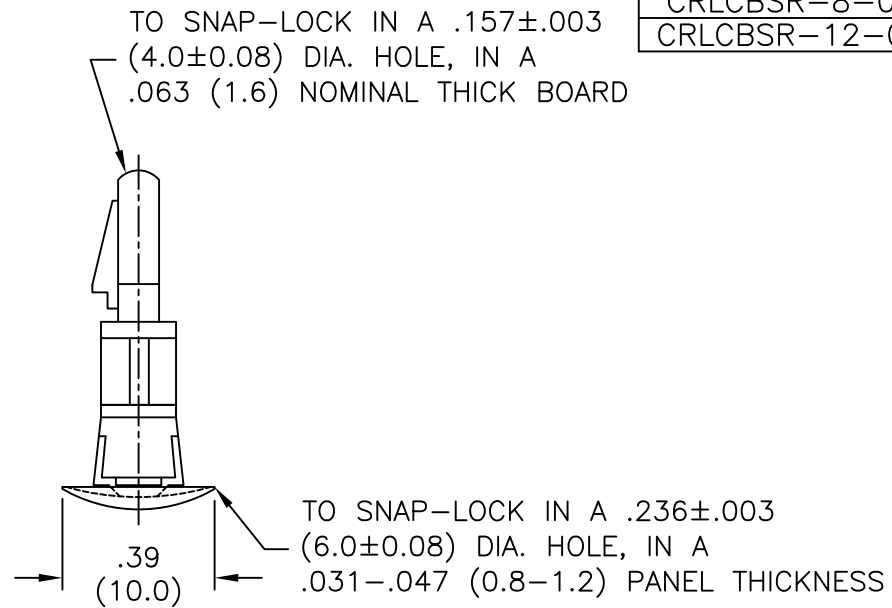
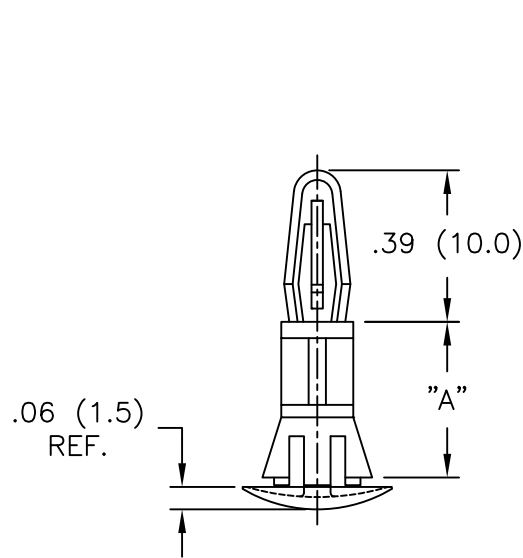

NOTES:

1. MATERIAL: NYLON 6/6 (RMS-01).  
FLAME RETARDANT, NYLON (RMS-19),  
AVAILABLE BY SPECIAL ORDER ONLY.  
TO ORDER, REPLACE "-01" WITH "-19"
2. MATERIAL: NYLON 4/6, HEAT STABILIZED, (RMS-109)  
AVAILABLE BY SPECIAL ORDER ONLY.  
TO ORDER, REPLACE "-01" WITH "-109".
3. COLOR: NATURAL.  
BLACK, AVAILABLE BY SPECIAL ORDER ONLY.  
TO ORDER, ADD "BK" TO PART NO.

F	ADDED NOTE 2 (RMS-109) BY SPECIAL ORDER	SM 06.06.02
E	UPDATED NOTES AND CHANGED FILE NO.	SM 05.08.02
D	DIM. TO S-L IN .24 (6.0)... ADDED; TABLE REDUCED; UL NOTES ADDED	PB 07.10.95
C	DIMS IN CHASSIS THKNS PUT TO 3 PLACES	PB 11.23.94
B	CONVERTED TO ACAD; DIM "A" WAS .411	PB 07.29.94
A	COMPLETE REDRAW, .40 WAS .39, .06 WAS .07, RMS-01 WAS RMS-48	RT 03.10.94
REV	DESCRIPTION	ENGR DATE

TITLE: CUPPED REVERSE LOCKING CBS, ROUND HOLE

TOLERANCES UNLESS NOTED  
.XX=±.010  
.XXX=±.005  
FRAC=1/64  
ANG=1°

FILE # CRLCBSR  
MAT'L: SEE NOTES  
RE: RICHCO, INC.

DWN: P.B.  
DT: 07-29-94  
APP:  
DT:  
RICHCO INC.  
PO BOX 804238, CHICAGO, 60680  
(773) 539-4060

		DWG IN IN (MM)	
PART #		FINAL	PRINT TYPE
SEE TABLE			CA