

PART NO.	"B" DIA. ±.010 [±0.25]	"C" DIA.	"D" REF.	"E" REF.	MOUNTING HOLE DIA. ±.003 [±0.08]	RECOMMENDED SCREW SIZE
CSP4-01	.295 [7.5]	----	----	.10 [2.5]	.195 [5.0]	#4 [M2.5]
CSP6-01	.394 [10.0]	.29 [7.3]	.12 [3.0]	.20 [5.0]	.256 [6.5]	#6 [M3.5]
CSP8-01	.436 [11.0]	.33 [8.3]	.14 [3.6]	.22 [5.5]	.272 [6.9]	#8 [M4]

PART NO.	"A" DIA. ±.010 [±0.25]	"B" DIA. ±.010 [±0.25]	MATING PART NO.
CSR4-224-01	.224 [5.7]	.295 [7.5]	CSP4-01
CSR4-295-01	.295 [7.5]		
CSR4-394-01	.394 [10.0]		
CSR4-591-01	.591 [15.0]		
CSR4-787-01	.787 [20]	.394 [10.0]	CSP6-01
CSR6-224-01	.224 [5.7]		
CSR6-295-01	.295 [7.5]		
CSR6-394-01	.394 [10.0]		
CSR6-591-01	.591 [15.0]	.436 [11.0]	CSP8-01
CSR6-787-01	.787 [20]		
CSR8-224-01	.224 [5.7]		
CSR8-295-01	.295 [7.5]		
CSR8-394-01	.394 [10.0]		
CSR8-591-01	.591 [15.0]		
CSR8-787-01	.787 [20]		

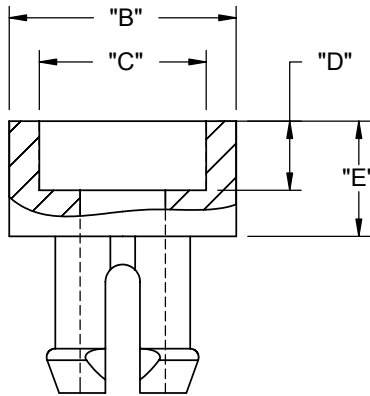

CSP(PIN)

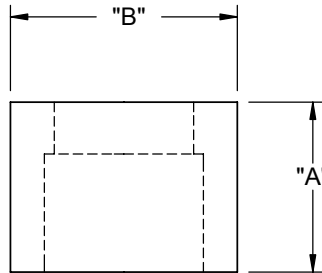

CSR (RETAINER)

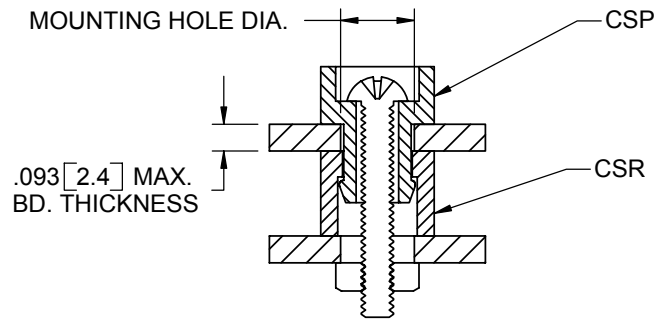

TYPICAL ASSEMBLY

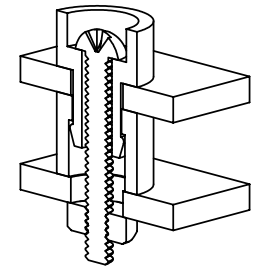

NOTES:
1. MATERIAL: NYLON 6/6 (RMS-01).
2. COLOR: NATURAL.

TITLE: COLLAR SPACERS				⊕	▭	DWG IN IN [MM]	QR
CREATED USING SOLIDWORKS	FILE #: CSP-CSR	DWN: R.S	APP: -	FINAL			
TOLERANCES UNLESS NOTED .XX=±.010 .XXX=±.005 FRAC.=±1/64 ANG.=±1°	SHEET: 1 OF 1	SHEET SIZE: A	DT: 04/07/95	CHKD: -	PART #		PRINT TYPE
RE: RICHCO, INC.	RICHCO, INC. ENG@RICHCO-INC.COM (773) 539-4060		SEE TABLE		CA		

REV.	DESCRIPTION	ENGR.	DATE
F	SEE ECN #817 FOR CHANGES	SM	07/06/04
-	SEE ENGINEERING FOR REV. A-E	--	----