

REV.	MODIFICATION.	DATE	DRN
01	PRODUCTION RELEASE	02/09/09	OW

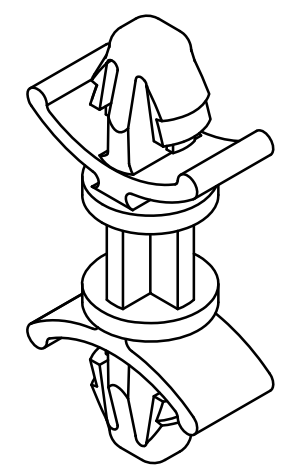
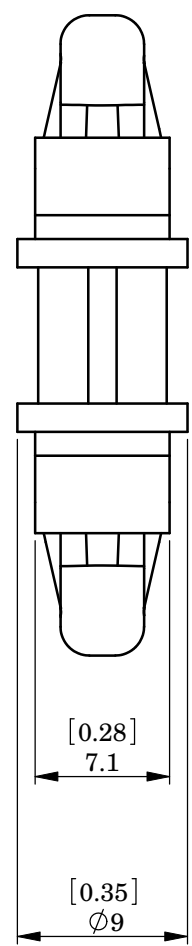
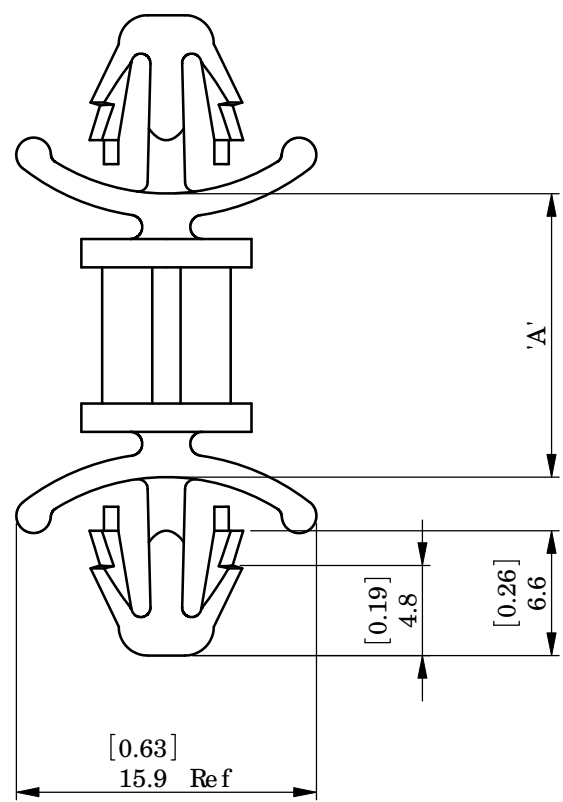

ALTERNATE UNITS FOR REFERENCE ONLY

INFORMATION CONTAINED IN THIS DOCUMENT IS CONFIDENTIAL TO RICHCO INTERNATIONAL Co. Ltd. AND MAY NOT BE DISCLOSED OR REPRODUCED IN WHOLE OR PART WITHOUT THEIR WRITTEN CONSENT

Material: Nylon 6/6 UL94 V-2 (RMS-01)	Material: Nylon 6/6 UL94 V-0 (RMS-19)	'A' DIM	HOLE Ø	PANEL THICKNESS
DLC BSHD-10M-01	DLC BSHD-10M-19	10 [0.39]	6.30 ±0.05 [0.25 ±0.002]	0.8 - 2.2 [0.03 - 0.09]
DLC BSHD-20M-01	DLC BSHD-20M-19	20 [0.79]		
DLC BSHD-25M-01	DLC BSHD-25M-19	25 [0.98]		
DLC BSHD-30M-01	DLC BSHD-30M-19	30 [1.18]		
DLC BSHD-35M-01	DLC BSHD-35M-19	35 [1.38]		

RICHCO, INC.
WWW.RICHCO-INC.COM

ALL DIMENSIONS IN mm
GENERAL TOLERANCES ±0.25
UNLESS OTHERWISE STATED
1 DECIMAL PLACE ±
2 DECIMAL PLACES ±
ANGULAR ±1°

THIRD ANGLE

MATERIAL: NYLON 6/6 UL94 V-2 (RMS-01)	COLOUR: NATURAL
--	--------------------

DESCRIPTION: HEAVY DUTY DUAL LOCKING CIRCUITBOARD SUPPORT	PART No: SEE TABLE
---	-----------------------

DRG No: 09-080	NPR No: EU9-0048	SHEET SIZE A4
-------------------	---------------------	------------------

DRN OW	DATE 13/08/09	CHKD TC	DATE 13/08/09	SCALE NTS	SHEET No. 1 OF 1
-----------	------------------	------------	------------------	--------------	---------------------