

PART NO.	"A" ±0.4 mm
DLSP-1-3M-01	3.0 mm
DLSP-1-4M-01	4.0 mm
DLSP-1-6M-01	6.0 mm
DLSP-1-8M-01	8.0 mm
DLSP-1-10M-01	10.0 mm
DLSP-1-12M-01	12.0 mm
DLSP-1-14M-01	14.0 mm
DLSP-1-16M-01	16.0 mm
DLSP-1-18M-01	18.0 mm
DLSP-1-25M-01	25.0 mm
DLSP-1-30M-01	30.0 mm

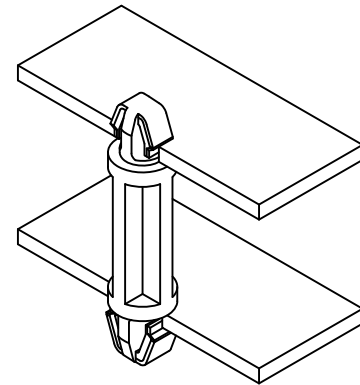
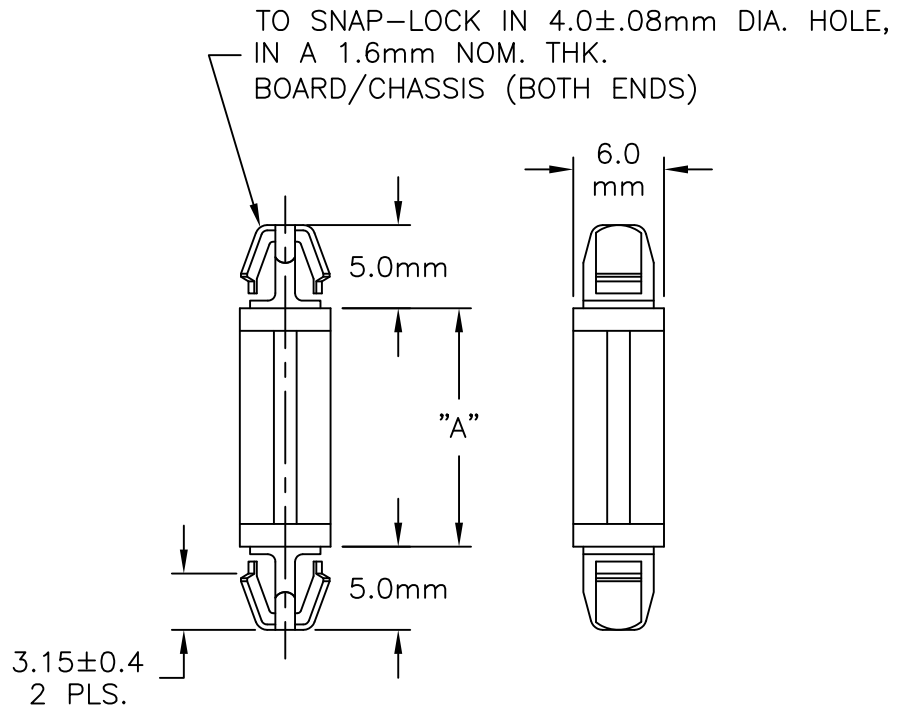

- NOTES:
- MATERIAL: NYLON 6/6 (RMS-01).
FLAME RETARDANT, NYLON (RMS-19),
AVAILABLE BY SPECIAL ORDER ONLY.
 - COLOR: NATURAL.

F	ADDED -25M, AND -30M PART NO.,SEE CO 200531	SK 05.10.10	TITLE: DUAL LOCKING SUPPORT POST (METRIC), TYPE 1				⊙	▭	DWG IN METRIC	QR
E	DIM. 3.15 WAS 3.7	SM 05.28.02	FILE # DLSP-1		DWN: P.B.	APP:		FINAL		
D	CHANGED FILE NUMBER	SM 05.10.01	MAT'L: SEE NOTE		DT: 10-04-94	DT:		PART #		
C	Tol. ±.08 added to dim 4.0 mm	JL 4.3.00	RE: RICHCO INC		RICHCO INC.		SEE TABLE		PRINT TYPE	
B	NOTE 2 REMOVED; 2ND CHART ADDED; DIM SEE CHART ADDED; DIM .24 (6) ADDED	PB 07.05.95	FRAC=±1/64		PO BOX 804238,CHICAGO,60680				CA	
A	-01 ADDED TO P/N'S	PB 11.09.94	ANG=±1'		(773) 539-4060					
REV	DESCRIPTION	ENGR DATE								