

PART NO.	"A" ±0.4 mm
DLSP-3-3M-01	3.0 mm
DLSP-3-4M-01	4.0 mm
DLSP-3-6M-01	6.0 mm
DLSP-3-8M-01	8.0 mm
DLSP-3-10M-01	10.0 mm
DLSP-3-12M-01	12.0 mm
DLSP-3-14M-01	14.0 mm
DLSP-3-16M-01	16.0 mm
DLSP-3-18M-01	18.0 mm

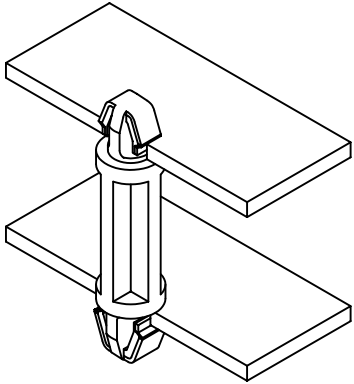
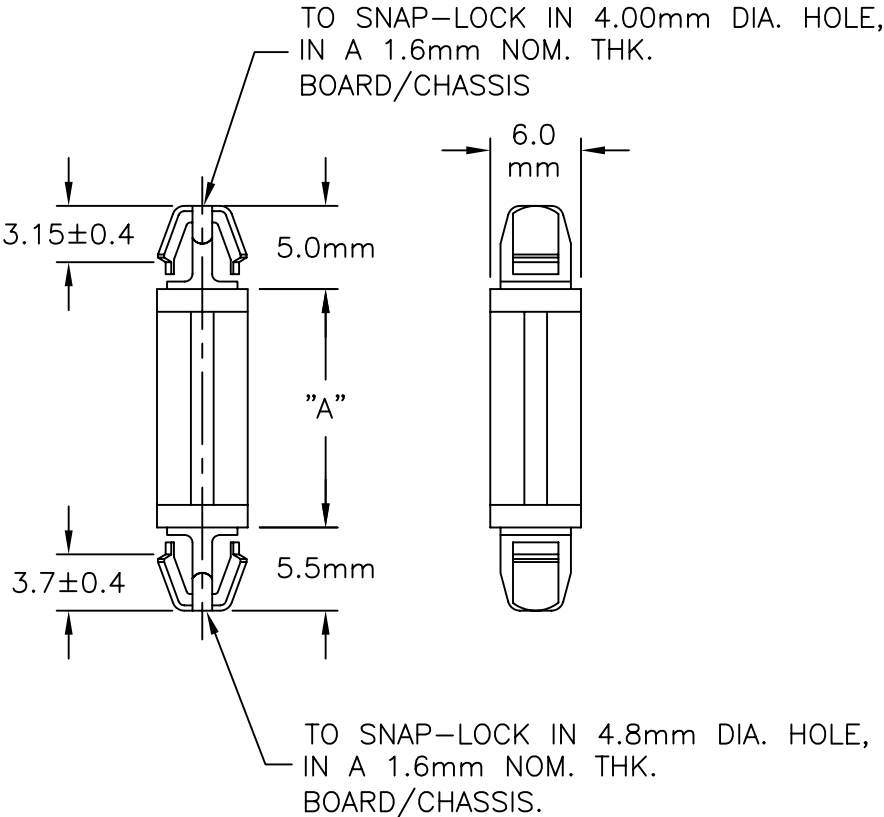

- NOTES:
- MATERIAL: NYLON 6/6 (RMS-01)  
FLAME RETARDANT, NYLON (RMS-19),  
AVAILABLE BY SPECIAL ORDER ONLY.
  - COLOR: NATURAL.

E		ADDED DIM. 3.15 AND TOL. TO DIM. 3.7	SM 05.28.02	TITLE: DUAL LOCKING SUPPORT POST (METRIC) TYPE 3			⊙	□	DWG IN METRIC	QR
D		CHANGED FILE NUMBER	SM 06.19.01	TOLERANCES UNLESS NOTED	FILE # DLSP-3	DWN: P.B.	APP:		FINAL	
C		Tol.±.08 added to dim 4.0 mm	JL 4.3.00	X.X=±0.25	MAT'L: SEE NOTES	DT: 10-04-94	DT:		PART #	
B		NOTE 2 REMOVED; 2ND CHART ADDED; DIM SEE CHART ADDED; DIM .24 (6) ADDED	PB 07.05.95	X.XX=±0.13	RE: RICHCO, INC.	RICHCO INC.		SEE TABLE		PRINT TYPE
A		-01 ADDED TO P/N'S	PB 11.09.94	FRAC=±1/64	PO BOX 804238, CHICAGO, 60680				CA	
REV		DESCRIPTION	ENGR DATE	ANG=±1'	(773) 539-4060					