

*PARTS AVAILABLE BY SPECIAL ORDER ONLY

TO PRESS-FIT IN A $.312 \pm .003$
(7.92 ± 0.08) DIA. HOLE, IN A
.25 (6.4) MIN. THICK PANEL

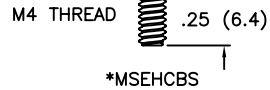
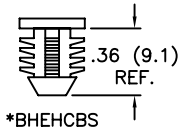

BASE STYLE	HEAD STYLE					
	STANDARD NOSE STANDARD CLIP "C"=.29 (7.5)	-8 STANDARD NOSE SHORT CLIP "C"=.24 (6.1)	-6 SHORT NOSE SHORT CLIP "C"=.24 (6.1)	-7 SHORT NOSE STANDARD CLIP "C"=.29 (7.5)	-9 NO NOSE SHORT CLIP "C"=.24 (6.1)	-10 NO NOSE STANDARD CLIP "C"=.29 (7.5)
<p>TO SNAP-LOCK IN A $.187 \pm .003$ (4.75 ± 0.08) DIA. HOLE IN A $.031 - .078$ ($0.79 - 1.98$) PANEL THICKNESS</p>	EHCBS-A-01 EHCBS-A-19	*EHCBS-8-A-01 *EHCBS-8-A-19	*EHCBS-6-A-01 *EHCBS-6-A-19	*EHCBS-7-A-01 *EHCBS-7-A-19	*EHCBS-9-A-01 *EHCBS-9-A-19	*EHCBS-10-A-01 *EHCBS-10-A-19
<p>FOR #6 (M3.5), SELF TAPPING SCREW.</p>	*TEHCBS-A-01 *TEHCBS-A-19	*TEHCBS-8-A-01 *TEHCBS-8-A-19	*TEHCBS-6-A-01 *TEHCBS-6-A-19	*TEHCBS-7-A-01 *TEHCBS-7-A-19	*TEHCBS-9-A-01 *TEHCBS-9-A-19	*TEHCBS-10-A-01 *TEHCBS-10-A-19

SELECT BASE STYLE FROM LEFT TABLE COLUMN AND HEAD STYLE FROM THE TOP OF THE TABLE. WHERE THE COLUMN & ROWS INTERSECT IS THE CORRESPONDING PART NO.

TO FIT A $.156 \pm .003$
(4.00 ± 0.08) DIA. HOLE, IN A
.062 (1.57) THICK PC BOARD

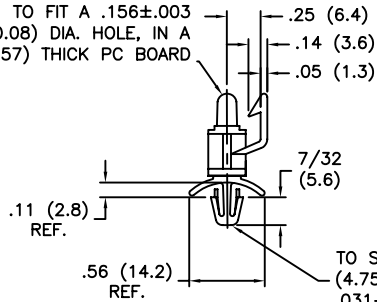

TO SNAP-LOCK IN A $.187 \pm .003$
(4.75 ± 0.08) DIA. HOLE IN A
 $.031 - .078$ ($0.79 - 1.98$) PANEL THICKNESS

EXAMPLE:

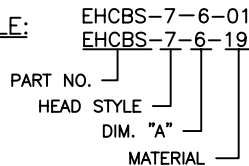

FOR DIMENSION "A" SEE CHART.

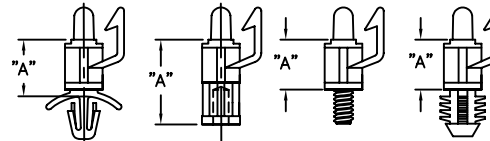

DIM. "A"	SIZE
-4**	1/4 (6.4)
-5	5/16 (7.9)
-6	3/8 (9.5)
-8	1/2 (12.7)
-10	5/8 (15.9)
-12	3/4 (19.1)
-14	7/8 (22.2)
-16	1 (25.4)

NOTES:

1. MATERIAL: NYLON 6/6 (RMS-01),
FLAME RETARDANT: NYLON (RMS-19),
2. COLOR: NATURAL.

**ONLY TEHCBS-4-01 OR "-19" AVAILABLE IN 1/4 (6.4) SIZE

I	SEE CO 200035 FOR CHANGES	SK 09.26.07
H	SEE ECN #1208 FOR CHANGES	SK 11.29.06
-	SEE ENGINEERING FOR REV A-G	-
REV	DESCRIPTION	ENGR DATE

TITLE: EDGE-HOLDING CIRCUIT BOARD SUPPORTS				DWG IN IN (MM)	FINAL	PRINT TYPE
TOLERANCES UNLESS NOTED .XX=±.010 .XXX=±.005 FRAC=±1/64 ANG=±1°	FILE # EHCBS	DWN: S.M.	APP:	IN (MM)	CA	
RE: RICHCO, INC.	MAT'L: SEE NOTES	DT: 12/05/01	DT:	PART #	SEE TABLE	
		RICHCO INC. PO BOX 804238, CHICAGO, 60680 (773) 539-4060				