

REV.	MODIFICATION.	DATE	DRN
01	Sales Release	24/03/09	PH

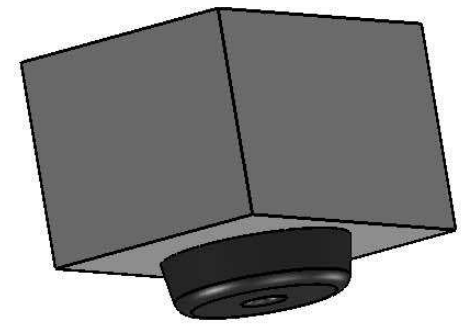
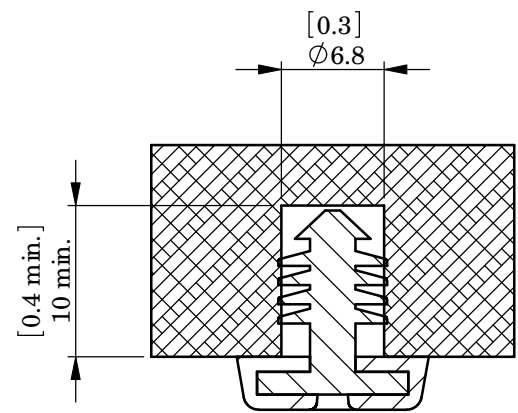
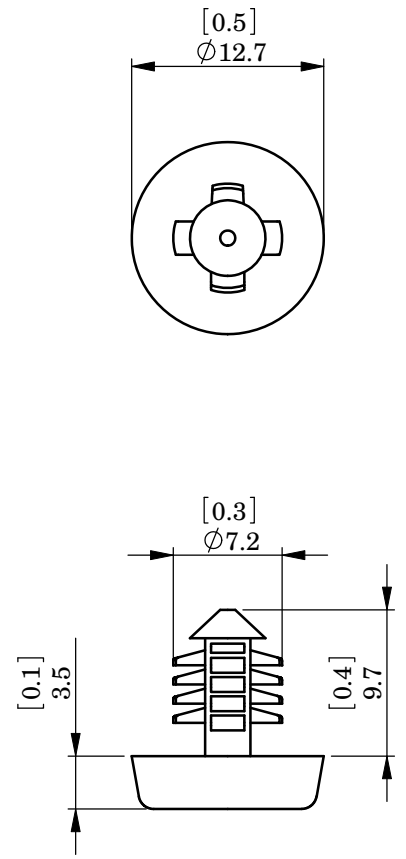

ALTERNATE UNITS FOR REFERENCE ONLY

INFORMATION CONTAINED IN THIS DOCUMENT IS CONFIDENTIAL TO RICHCO INTERNATIONAL Co. Ltd. AND MAY NOT BE DISCLOSED OR REPRODUCED IN WHOLE OR PART WITHOUT THEIR WRITTEN CONSENT

	ALL DIMENSIONS IN mm GENERAL TOLERANCES ±0.25 UNLESS OTHERWISE STATED 1 DECIMAL PLACE ± 2 DECIMAL PLACES ± ANGULAR ±1°	THIRD ANGLE

Part Number	Part Description	Material
FBR-1	Barbed Fastener	Nylon 6/6 UL-V2 (RMS-01)
	Elastomer Foot	Thermoplastic Elastomer 60 Shore A (RMS-351)

MATERIAL: See Table		COLOUR: Black	
DESCRIPTION: Foot, Barbed Rivet		PART No: FBR-1	
DRG No: 09-041	NPR No: FR09-0002	SHEET SIZE A4	
DRN PH	DATE 24/03/09	CHKD SF	DATE 11/05/09
SCALE NTS	SHEET No. 1 OF 1		

PANEL DETAILS
 Hole - $\varnothing 6.8 \pm 0.08$ (0.268 ±0.003)
 Panel Thickness - Blind Hole - 10 (0.394) Depth Minimal