

PART NUMBER	FAN SIZE	FAN HOLE SPACING	"D"	"F"	"G" REF
FGA-40	40 [1.57]	32 [1.26]	4.5 [.18]	3.5 [.14]	36 [1.42]
FGA-50	50 [1.97]	40 [1.57]			46 [1.81]
FGA-60	60 [2.36]	50 [1.97]	5 [.20]	4 [.16]	56 [2.20]
FGA-70	70 [2.76]	61.5 [2.42]			66 [2.60]
FGA-80	80 [3.15]	71.5 [2.81]			75 [2.95]
FGA-92	92 [3.62]	82.5 [3.25]			87 [3.43]
FGA-120	120 [4.72]	105 [4.13]			115 [4.53]

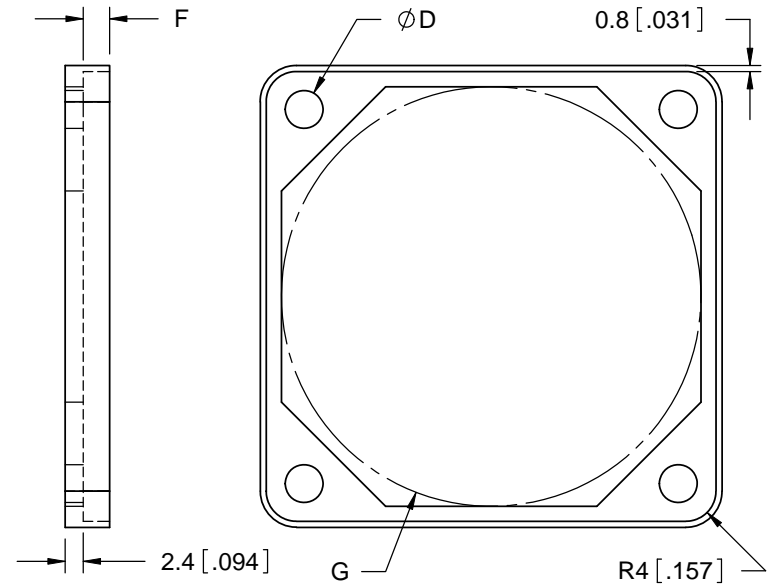
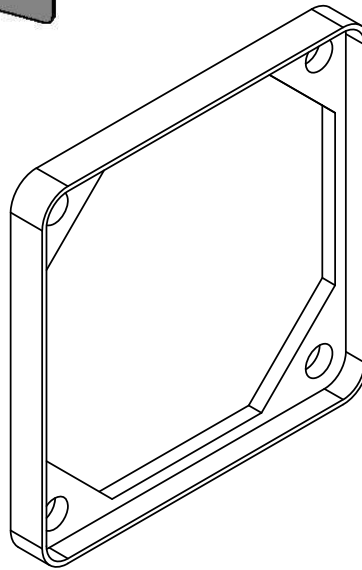

NOTES:

1. MATERIAL: SILICONE RUBBER, 40 SHORE A (RMS-101)
2. COLOR: BLACK
3. ALTERNATE UNITS FOR REFERENCE ONLY.
4. FAN NOT SUPPLIED.

TITLE: FAN MOUNT GASKET				UNITS mm [IN]	QR
CREATED USING SOLIDWORKS	FILE #: FGA	DWN: D.J.Z.	APP: D.J.Z.	FINAL	
GENERAL TOLERANCE UNLESS NOTED ± 0.25 ANG. $\pm 1^\circ$	SHEET: 1 OF 1	SHEET SIZE: A	DT: 05/17/2010	CHKD: M.J.B.	PART #
RE: RICHCO INC.	RICHCO, INC. ENG@RICHCO-INC.COM (773) 539-4060		SEE TABLE		PRINT TYPE CA

REV.	DESCRIPTION	ENGR.	DATE
A	RELEASED FOR PRODUCTION	SK	07/15/10