

FIG. 1

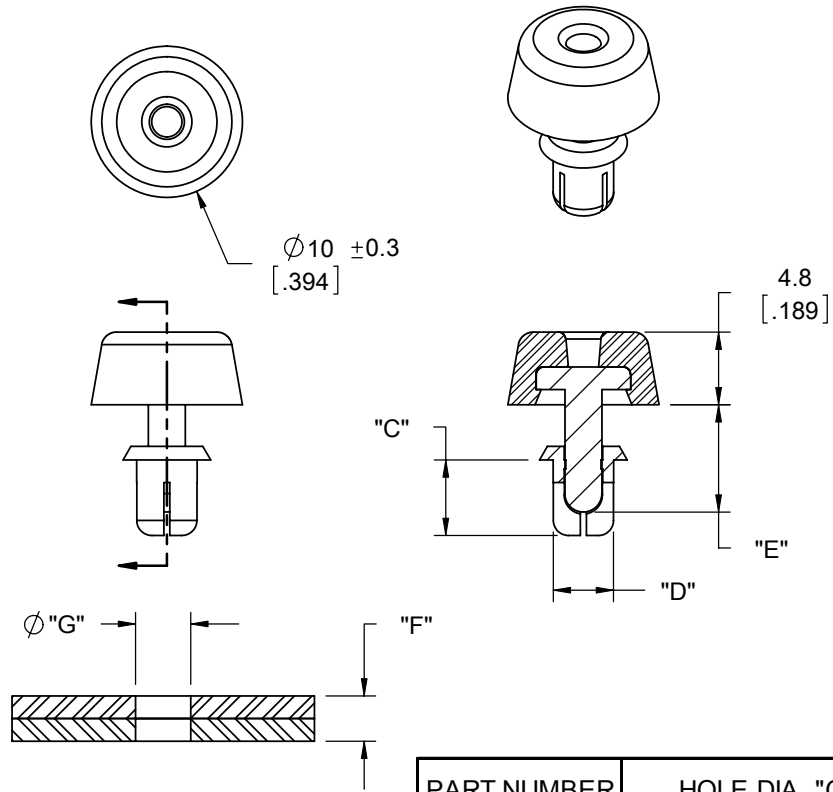
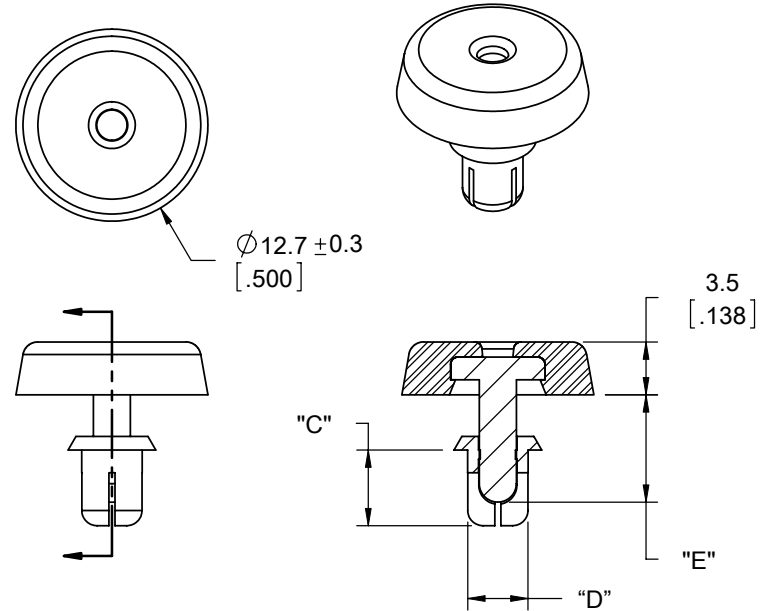

FIG. 2



NOTES:

1. RIVET MATERIAL: NYLON 6 UL 94 V-2 (RMS-52).
- FOOT MATERIAL: THERMOPLASTIC ELASTOMER (RMS-351).
2. COLOR: BLACK
3. "G" AND "F" REFER TO PANEL HOLE SIZE AND THICKNESS.
4. ALTERNATE UNITS FOR REFERENCE ONLY.

PART NUMBER	HOLE DIA. "G"	THICKNESS "F"	"C" ± 0.3	"D"	"E" ± 0.3	FIG. NO.
FSR-1	3.6 - 3.7 [.142 - .146]	1.2 - 2.1 [.047 - .083]	3.5 [.138]	3.5 [.138]	5.1 [.201]	1
FSR-2	3.6 - 3.7 [.142 - .146]	2.1 - 3 [.083 - .118]	4.5 [.177]	3.5 [.138]	6.1 [.240]	1
FSR-3	4.1 - 4.2 [.161 - .165]	2.5 - 3.5 [.098 - .138]	5 [.197]	4 [.157]	7.1 [.280]	1
FSR-4	3.6 - 3.7 [.142 - .146]	1.2 - 2.1 [.047 - .083]	3.5 [.138]	3.5 [.138]	5.1 [.201]	2
FSR-5	3.6 - 3.7 [.142 - .146]	2.1 - 3 [.083 - .118]	4.5 [.177]	3.5 [.138]	6.1 [.240]	2
FSR-6	4.1 - 4.2 [.161 - .165]	2.5 - 3.5 [.098 - .138]	5 [.197]	4 [.157]	7.1 [.280]	2

TITLE: FOOT SNAP RIVET				DWG IN MM [IN]		FINAL	
CREATED USING SOLIDWORKS	FILE #: FSR	DWN: R.D.G.	APP: R.D.G.	SHEET: 1 OF 1		SHEET SIZE: A	
TOLERANCES UNLESS NOTED	RE: RICHCO, INC.	DT: 01/10/07	CHKD: D.J.Z.	RE: RICHCO, INC.		PART # SEE TABLE	
0-10=±0.1				RICHCO, INC.		PRINT TYPE CA	
10.01-30=±0.3				ENG@RICHCO-INC.COM			
30.01-50=±0.5				(773) 539-4060			
ANG.=±1°							

A	RELEASED FOR PRODUCTION	SK	06/27/07
REV.	DESCRIPTION	ENGR.	DATE