

PART NO.	DIM "A" ±.015 (±0.4)
LCBST-2-01	1/8 (3.2)
LCBST-3-01	3/16 (4.8)
LCBST-4-01	1/4 (6.4)
LCBST-5-01	5/16 (7.9)
LCBST-6-01	3/8 (9.5)
LCBST-7-01	7/16 (11.1)
LCBST-8-01	1/2 (12.7)
LCBST-9-01	9/16 (14.3)
LCBST-10-01	5/8 (15.9)

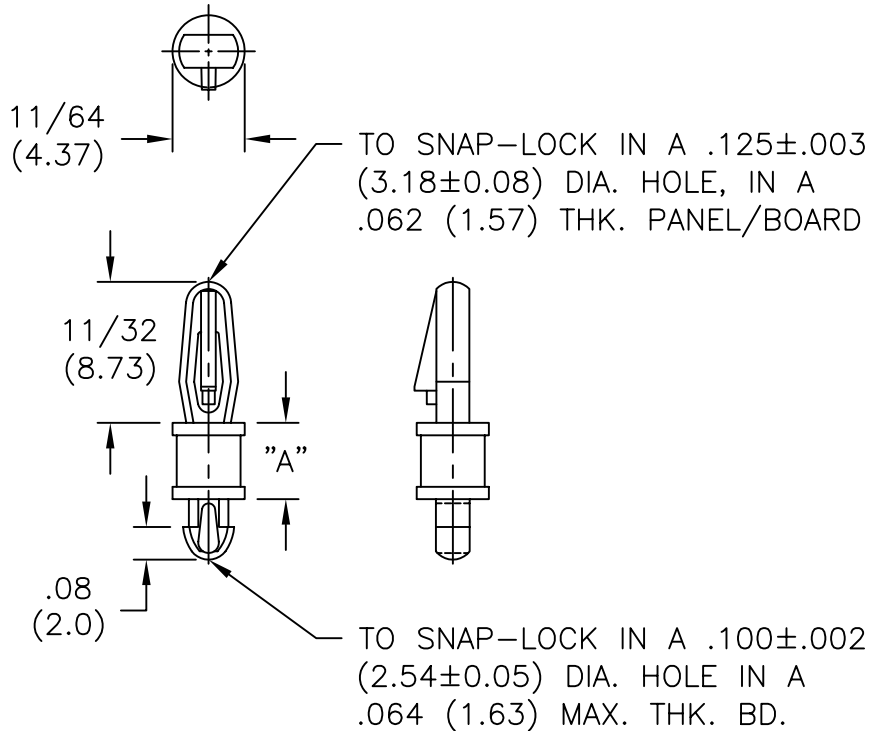

NOTES:

- MATERIAL: NYLON 6/6 (RMS-01)
FLAME RETARDANT, NYLON (RMS-19),
AVAILABLE BY SPECIAL ORDER ONLY.
- COLOR: NATURAL.

B	SEE ECN #886 FOR CHANGES	S.M. 12.01.04
A	UPDATED NOTES & CHANGED FILE NO.	S.M. 07.31.02
REV	DESCRIPTION	ENGR DATE

TITLE: LOCKING CIRCUIT BOARD SUPPORT, TEARDROP



DWG IN
IN (MM)

FINAL

TOLERANCES UNLESS NOTED .XX=±.010 .XXX=±.005 FRAC=±1/64 ANG=±1°	FILE # LCBST	DWN: J.B.	APP:	PART # SEE TABLE	PRINT TYPE CA
	MAT'L: SEE NOTES	DT: 01-08-95	DT:		
	RE: RICHCO, INC.	RICHCO INC. PO BOX 804238, CHICAGO, 60680 (773) 539-4060			