

PART NO. STYLE 1. .098 [2.5] DIA. HOLE	PART NO. STYLE 2. .138 [3.5] DIA. HOLE	"A"±.015
MDLSP1-02M-01	MDLSP2-02M-01	.079 [2]
MDLSP1-03M-01	MDLSP2-03M-01	.118 [3]
MDLSP1-04M-01	MDLSP2-04M-01	.156 [4]
MDLSP1-05M-01	MDLSP2-05M-01	.197 [5]
MDLSP1-06M-01	MDLSP2-06M-01	.236 [6]
MDLSP1-07M-01	MDLSP2-07M-01	.276 [7]
MDLSP1-08M-01	MDLSP2-08M-01	.315 [8]
MDLSP1-09M-01	MDLSP2-09M-01	.354 [9]
MDLSP1-10M-01	MDLSP2-10M-01	.394 [10]
MDLSP1-12M-01	MDLSP2-12M-01	.472 [12]
MDLSP1-14M-01	MDLSP2-14M-01	.551 [14]
MDLSP1-16M-01	MDLSP2-16M-01	.630 [16]
MDLSP1-18M-01	MDLSP2-18M-01	.709 [18]
MDLSP1-20M-01	MDLSP2-20M-01	.787 [20]
MDLSP1-22M-01	MDLSP2-22M-01	.866 [22]

STYLE 1.

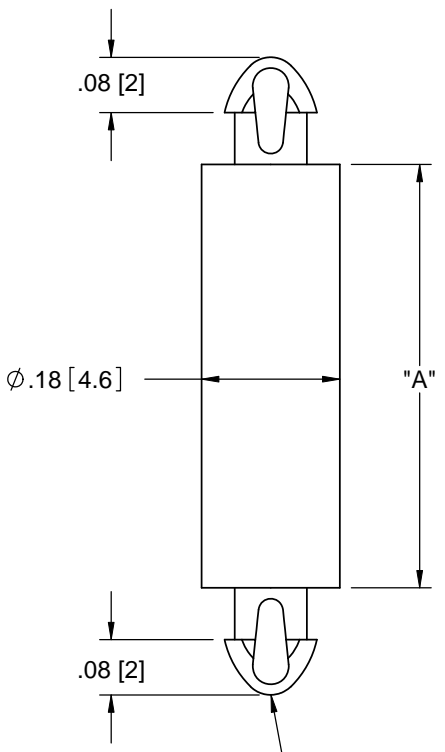

TO SNAP-LOCK IN A .098±.002 [2.5±0.05] DIA. HOLE, IN A .065 (1.65) MAX. THICK BOARD (BOTH ENDS)

STYLE 2.

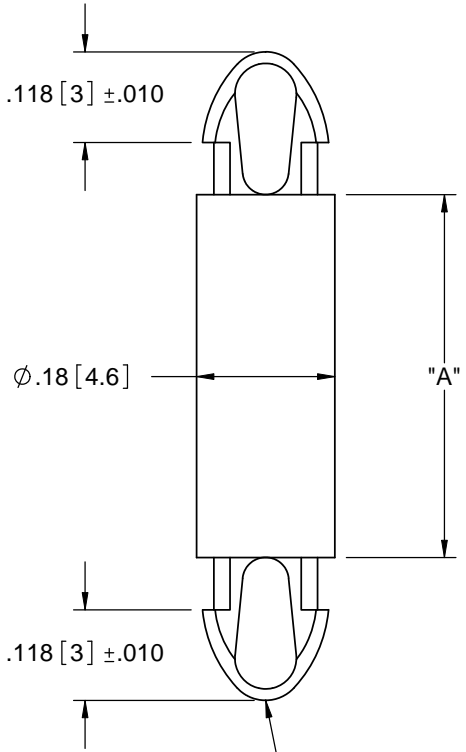

TO SNAP-LOCK IN A .138±.002 [3.5±0.05] DIA. HOLE, IN A .065 (1.65) MAX. THICK BOARD (BOTH ENDS)

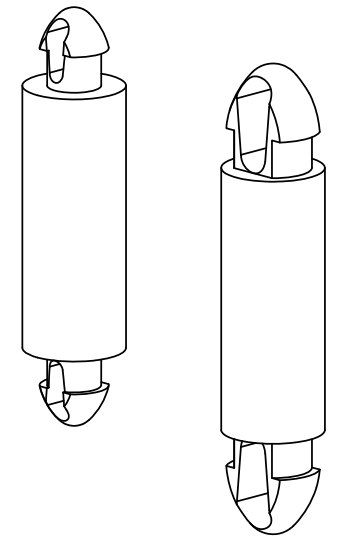

NOTES:

- MATERIAL: NYLON 6/6 UL 94 V-2 (RMS-01),
FLAME RETARDANT NYLON 6/6 UL 94 V-0 (RMS-19),
AVAILABLE BY SPECIAL ORDER ONLY.
- COLOR: NATURAL

REV.	DESCRIPTION	ENGR.	DATE
H	SEE CO 200289 FIR CHANGES	SK	12.04.08
G	REDRAWN, SEE ECN #1068 FOR CHANGES	SK	10/06/05
-	SEE ENG. FOR REV A-F	-	--

TITLE: MINIATURE DUAL LOCKING SUPPORT POST				DWG IN IN [MM]		FINAL		QR	
CREATED USING SOLIDWORKS		FILE #: MDLSP1&2	DWN: SK	APP: RT		PART # SEE TABLE A			
TOLERANCES UNLESS NOTED .XX=±.010 .XXX=±.005 FRAC.=±1/64 ANG.=±1°		SHEET: 1 OF 1	SHEET SIZE: A	DT: 10/06/05	CHKD: SJ				
RE: RICHCO, INC.			RICHCO, INC. ENG@RICHCO-INC.COM (773) 539-4060						