

Mat'l: UL94 V2 Nylon 6/6 Color: Natural	Screw Size	"L" ± .015 (0.38)	"A" ± .007 (0.18)	"B" ± .007 (0.18)	"C" ± .005 (0.13)	"D" ± .005 (0.13)	Material
MNI-2-2	#2 (M2)	.031 (0.8)	.181 (4.6)	.047 (1.2)	.120 (3)	.090 (2.3)	RMS-01
MNI-2-4		.063 (1.6)			.118 (3)		
MNI-2-6		.093 (2.4)			.145 (3.7)		
MNI-4-2	#4 (M2.5)	.031 (0.8)	.235 (6)		.140 (3.6)	.115 (2.9)	
MNI-4-3		.046 (1.2)					
MNI-4-4		.063 (1.6)					
MNI-4-5		.084 (2.1)					
MNI-4-6		.093 (2.4)					
MNI-4-8		.125 (3.2)					
MNI-4-10		.156 (4)					
MNI-4-12		.187 (4.7)					
MNI-4-16		.250 (6.4)					
MNI-4-24	.375 (9.5)						
MNI-5-3	#5 (M3)	.051 (1.3)	.370 (9.4)	.236 (6)	.128 (3.3)	RMS-48	
MNI-6-2	#6 (M3.5)	.031 (0.8)	.290 (7.4)	.063 (1.6)	.170 (4.3)	.140 (3.6)	RMS-01
MNI-6-4		.063 (1.6)					RMS-48
MNI-6-6		.093 (2.4)					RMS-01
MNI-6-8		.125 (3.2)					RMS-48
MNI-6-12		.187 (4.7)					RMS-01
MNI-6-16		.250 (6.4)					RMS-48
MNI-6-24		.375 (9.5)					RMS-01
MNI-6-32		.500 (12.7)					RMS-48
MNI-8-2	#8 (M4)	.031 (0.8)	.344 (8.7)	.063 (1.6)	.205 (5.2)	.173 (4.4)	RMS-01
MNI-8-4		.063 (1.6)					RMS-48
MNI-8-6		.093 (2.4)					RMS-01
MNI-8-8		.125 (3.2)					RMS-48
MNI-8-12		.187 (4.7)					RMS-01
MNI-8-16		.250 (6.4)					RMS-48
MNI-8-24		.375 (9.5)					RMS-01
MNI-8-32	.500 (12.7)	RMS-48					
MNI-10-2	#10 (M5)	.031 (0.8)	.399 (10.1)	.063 (1.6)	.260 (6.6)	.200 (5.1)	RMS-01
MNI-10-4		.063 (1.6)					RMS-48
MNI-10-6		.093 (2.4)					RMS-01
MNI-10-8		.125 (3.2)					RMS-48
MNI-10-12		.187 (4.7)					RMS-01
MNI-10-16		.250 (6.4)					RMS-48
MNI-10-24		.375 (9.5)					RMS-01
MNI-10-32		.500 (12.7)					RMS-48
MNI1/4-2	1/4 (M6)	.031 (0.8)	.513 (13)	.065 (1.7)	.312 (7.9)	.260 (6.6)	RMS-01
MNI1/4-4		.063 (1.6)					RMS-48
MNI1/4-6		.093 (2.4)					RMS-01
MNI1/4-12		.187 (4.7)					RMS-48
MNI1/4-16		.250 (6.4)					RMS-01
MNI1/4-24		.375 (9.5)					RMS-48
MNI1/4-32		.500 (12.7)					RMS-01
MNI5/16-6	5/16 (M8)	.093 (2.4)	.620 (15.7)	.063 (1.6)	.360 (9.1)	.320 (8.1)	RMS-01
MNI5/16-12		.187 (4.7)					RMS-48
MNI5/16-16		.250 (6.4)					RMS-01
MNI-M2.5-1.3	M2.5	.051 (1.3)	.248 (6.3)	.047 (1.2)	.138 (3.5)	.114 (2.9)	RMS-48
MNI-M2.5-3.6		.142 (3.6)	.280 (7.1)	.059 (1.5)	.150 (3.8)	.122 (3.1)	RMS-01
MNIM3-1.0	M3	.039 (1)	.280 (7.1)	.039 (1)	.150 (3.8)	.122 (3.1)	RMS-48
MNIM3-1.3		.051 (1.3)	.347 (8.8)	.047 (1.2)	.236 (6)	.126 (3.2)	RMS-01
MNI M3-2.5		.098 (2.5)	.280 (7.1)	.039 (1)	.150 (3.8)	.122 (3.1)	RMS-48
MNIM3-3.5		.137 (3.5)	.280 (7.1)	.039 (1)	.150 (3.8)	.122 (3.1)	RMS-01

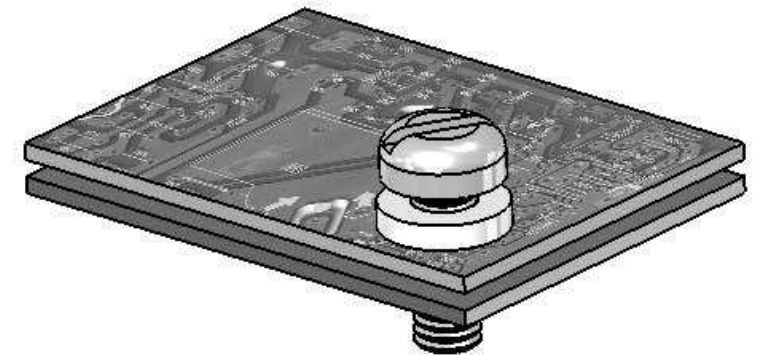
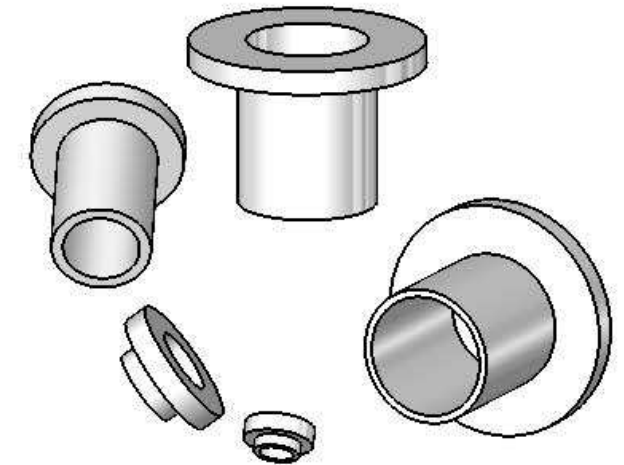
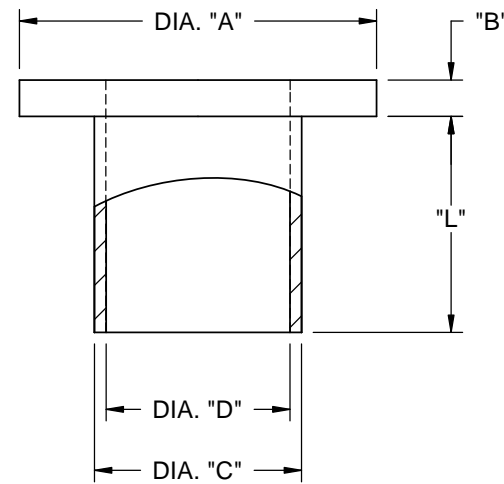
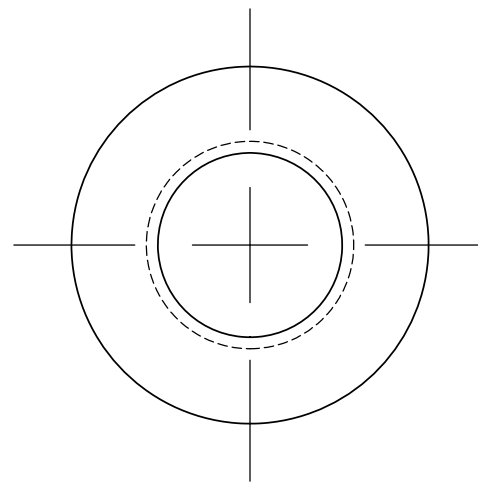

NOTES:
1. MATERIAL: NYLON 6/6 UL 94 V-2
- NYLON 4/6 UL 94 V-2 (RMS-109),
AVAILABLE BY SPECIAL ORDER ONLY.
TO ORDER ADD "-109" TO THE END OF PART NO.
2. COLOR: NATURAL

REV.	DESCRIPTION	ENGR.	DATE
S	SEE CO 200773 FOR CHANGES	SK	04.30.12
R	SEE CO 200581 FOR CHANGES	SK	09/14/10
Q	SEE CO 200403 FOR CHANGES	SK	07/31/09
P	SEE CO 200276 FOR CHANGES	SK	11/12/08
-	SEE ENGINEERING FOR REV A-O	-	-

TITLE: MOLDED NYLON INSULATORS				DWG IN IN [MM]		FINAL	
CREATED USING SOLIDWORKS	FILE #: MNI	DWN: SM	APP: SM	PART #			
TOLERANCES UNLESS NOTED .XX=±.010 .XXX=±.005 FRAC.=±1/64 ANG.=±1°	SHEET: 1 OF 1	SHEET SIZE: B	DT: 10/01/04	CHKD: SJ	SEE TABLE		
RE: RICHCO, INC.		RICHCO, INC. ENG@RICHCO-INC.COM (773) 539-4060		PRINT TYPE CA			