

PART NO.	HOLE DIAMETER	PANEL THICKNESS	HEAD DIAMETER "A"±.020	TO ACCOMMODATE BUNDLE DIA. "B" REF	OVERALL HEIGHT "C"±.010	"D"			
PGSB-0305	.189±.003 [4.8]	.063-.067 [1.6-1.7]	.26 [6.5]	.125 [3.2]	.24 [6]	.051 [1.3]			
PGSB-1	.250±.003 [6.35]	.062 [1.57] MAX	.312 [7.9]	.187 [4.7]	.312 [7.9]	.063 [1.6]			
PGSB-2	.312±.003 [7.9]		.375 [9.5]	.240 [6.1]	.237 [6]	.050 [1.27]			
PGSB-3			.468 [11.9]	.187 [4.7]	.250 [6.35]	.406 [10.3]	.055 [1.4]		
PGSB-4	.375±.002 [9.5]	.031-.125 [0.8-3.2]	.468 [11.9]	.284 [7.2]	.260 [6.6]	.051 [1.3]			
PGSB-5	.394±.003 [10]	.031-.125 [0.8-3.2]	.531 [13.5]	.270 [6.85]	.406 [10.3]	.055 [1.4]			
PGSB-6				.312 [7.9]					
PGSB-7				.250 [6.35]					
PGSB-8	.468±.002 [11.9]	.062 [1.57] MAX	.343 [8.7]	.250 [6.35]	.050 [1.27]				
PGSB-9	.500±.002 [12.7]	.031-.125 [0.8-3.2]	.578 [14.7]	.250 [6.35]	.406 [10.3]	.063 [1.6]			
PGSB-10				.312 [7.9]					
PGSB-11	.625±.002 [15.9]	.062 [1.57] MAX	.562 [14.3]	.375 [9.5]	.250 [6.35]				
PGSB-12				.402 [10.2]					
PGSB-1013				.354 [9]					
PGSB-13	.512±.003 [13]	.031-.118 [0.8-3]	.591 [15]	.406 [10.3]	.250 [6.35]	.051 [1.3]			
PGSB-14	.562±.002 [14.3]	.031-.125 [0.8-3.2]	.656 [16.7]	.312 [7.9]	.406 [10.3]		.063 [1.6]		
PGSB-15				.391 [9.9]					
PGSB-16				.437 [11.1]					
PGSB-17	.625±.002 [15.9]	.062 [1.57] MAX	.703 [17.85]	.250 [6.35]	.250 [6.35]				
PGSB-18				.437 [11.1]					
PGSB-19	.630±.003 [16]	.055-.139 [1.4-3.5]	.709 [18]	.504 [12.8]	.413 [10.5]		.059 [1.5]		
PGSB-1316	.687±.002 [17.5]	.031-.125 [0.8-3.2]	.781 [19.8]	.500 [12.7]	.406 [10.3]		.063 [1.6]		
PGSB-20				.562 [14.3]					
PGSB-21	.748±.003 [19]	.039-.130 [1-3.3]	.854 [21.7]	.602 [15.3]	.433 [11]		.059 [1.5]		
PGSB-1519	.750±.002 [19.1]	.031-.125 [0.8-3.2]	.843 [21.4]	.500 [12.7]	.406 [10.3]	.063 [1.6]			
PGSB-22				.562 [14.3]					
PGSB-23				.828 [21]					
PGSB-24	.781±.002 [19.8]	.062 [1.57] MAX	.859 [21.8]	.625 [15.9]	.250 [6.35]				
PGSB-25				.859 [21.8]					
PGSB-1822	.866±.003 [22]	.035-.091 [0.9-2.3]	.976 [24.8]	.717 [18.2]		.059 [1.5]			
PGSB-26	.875±.002 [22.2]	.031-.125 [0.8-3.2]	.953 [24.2]	.500 [12.7]	.453 [11.5]				
PGSB-27				.562 [14.3]					
PGSB-28				.625 [15.9]					
PGSB-29				.687 [17.45]					
PGSB-30	1.000±.002 [25.4]	.062 [1.57] MAX	.937 [23.8]	.750 [19.1]	.250 [6.35]	.063 [1.6]			
PGSB-31				.766 [19.45]					
PGSB-32				.812 [20.6]					
PGSB-33				.875 [22.2]					
PGSB-34	1.097±.004 [27.86]	.031-.125 [0.8-3.2]	1.218 [31]	.937 [23.8]	.453 [11.5]				
PGSB-2428				.945 [24]					
PGSB-2530				.984 [25]					
PGSB-2634	1.347±.003 [34.2]	.039-.126 [1-3.2]	1.496 [38]	1.031 [26.2]	.441 [11.2]	.059 [1.5]			
PGSB-35	1.250±.002 [31.75]	.031-.125 [0.8-3.2]	1.312 [33.3]	.937 [23.8]	.453 [11.5]	.063 [1.6]			
PGSB-36	1.375±.002 [34.9]		1.468 [37.3]	1.000 [25.4]					
PGSB-37	1.500±.002 [38.1]		1.609 [40.9]	1.062 [27]					
PGSB-38			1.125 [28.6]						
PGSB-39			1.312 [33.3]						
PGSB-40	1.750±.002 [44.45]		1.875 [47.6]	1.375 [34.9]					
PGSB-41	2.000±.002 [50.8]		2.125 [54]	1.640 [41.7]			1.750 [44.5]		
PGSB-42				1.750 [44.5]					
PGSB-43	2.250±.003 [57.2]		.250 [6.35] MAX	2.480 [63]			1.850 [47]	.720 [18.2]	

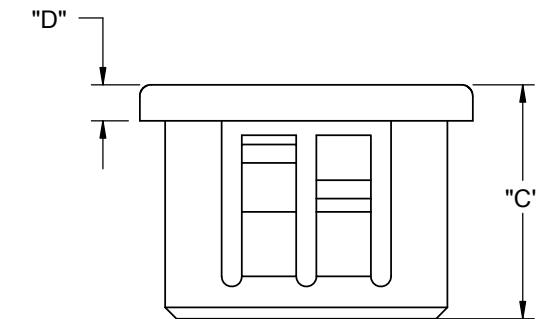
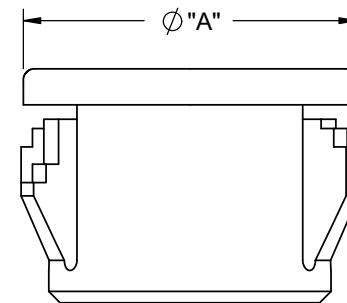
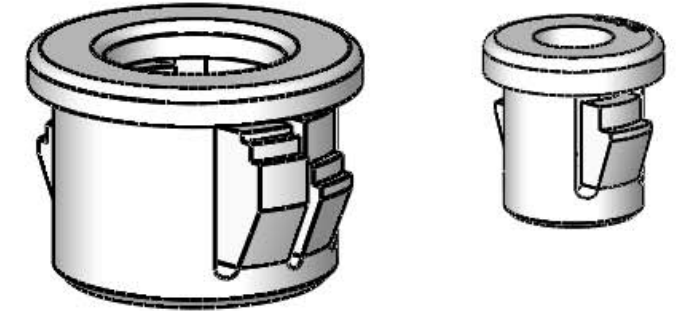
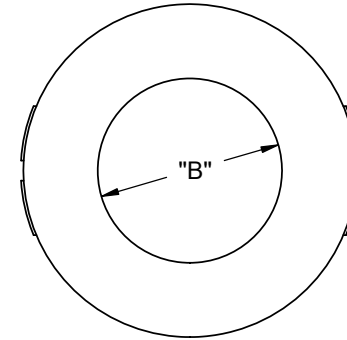

- NOTES:
- MATERIAL: NYLON 6/6 UL 94 V-2 (RMS-01)
-NYLON 6/6 UL 94 V-0 (RMS-19),
AVAILABLE BY SPECIAL ORDER ONLY. TO ORDER, ADD SUFFIX "-V0"
 - COLOR: BLACK.
COLOR WHITE AVAILABLE BY SPECIAL ORDER ONLY.
 - PARTS MAY APPEAR WITH ONE OR TWO LOCKING MECHANISMS PER SIDE.
-SOME PARTS MAY APPEAR WITH RICHCO LOGO.

I	SEE CO 200743 FOR CHANGES	SK	02/09/2012
-	SEE ENGINEERING FOR REVISIONS A TO H	--	-----
	DESCRIPTION	ENGR.	DATE

TITLE: SNAP BUSHINGS CLOSED				DWG IN IN [MM]		FINAL	
CREATED USING SOLIDWORKS	FILE #: PGSB	DWN: SK	APP: SK	PART #			
TOLERANCES UNLESS NOTED .XX=±.010 .XXX=±.005 FRAC.=±1/64 ANG.=±1°	SHEET: 1 OF 1	SHEET SIZE: B	DT: 11/17/08	CHKD: SJ	SEE TABLE		PRINT TYPE
RE: RICHCO, INC.			RICHCO, INC. ENG@RICHCO-INC.COM (773) 539-4060		CA		