

PART NO.	DIM. "A"
PSC-1	3/8 [9.5]
PSC-2	1/2 [12.7]
PSC-3	5/8 [15.9]
PSC-4	3/4 [19.1]

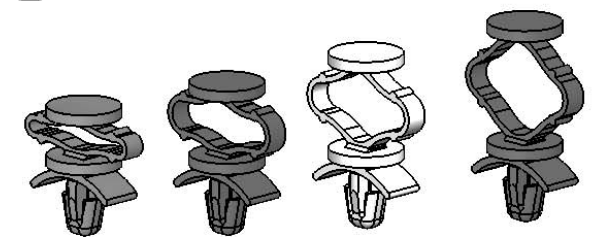
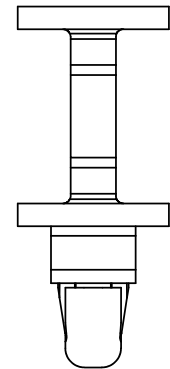
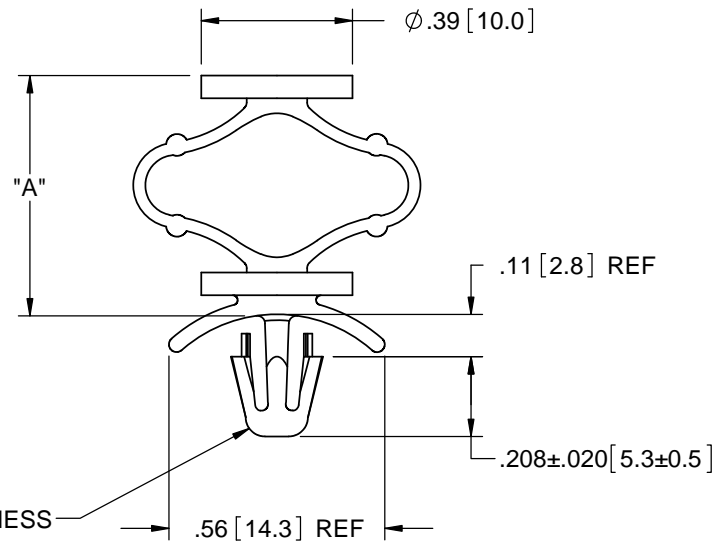
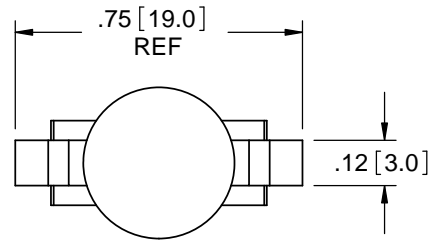

TO SNAP-LOCK IN A .187±.003
[4.75±0.08] DIA. HOLE, IN A
.031-.078 [0.79-1.98] PANEL THICKNESS

- NOTES:
 1. MATERIAL: IMPACT MODIFIED NYLON 6/6
 UV STABILIZED UL 94 HB (RMS-73)
 2. COLOR: NATURAL.
 3. ALTERNATE UNITS [mm] ARE FOR REFERENCE ONLY

TITLE: PUSH SPACER, CUSHION				UNITS: IN [mm]		FINAL	
CREATED USING SOLIDWORKS	FILE #: PSC	DWN: SK	APP: SK				
TOLERANCES UNLESS NOTED .XX=±.010 .XXX=±.005 FRAC.=±1/64 ANG.=±1°	SHEET: 1 OF 1	SHEET SIZE: A	DT: 07/07/05	CHKD: DJZ	PART #		PRINT TYPE
RE: RICHCO, INC.		RICHCO, INC. ENG@RICHCO-INC.COM (773) 539-4060		SEE TABLE		CA	

REV.	DESCRIPTION	ENGR.	DATE
D	CORRECT DIM. FROM 7/32"[5.3] TO .208[5.3], ECN# 1386	DZ	10/24/2013
C	SEE ECN #1208 FOR CHANGES	SK	11/29/2006
B	SEE ECN #1121 FOR CHANGES	SK	01/13/2006
A	RELEASED FOR PRODUCTION	SK	08/10/2005