

A B C D E F

REV.	MODIFICATION.	DATE	DRN
01	PRODUCTION RELEASE	17/12/08	PH
02	CO2010789	26/08/09	MT

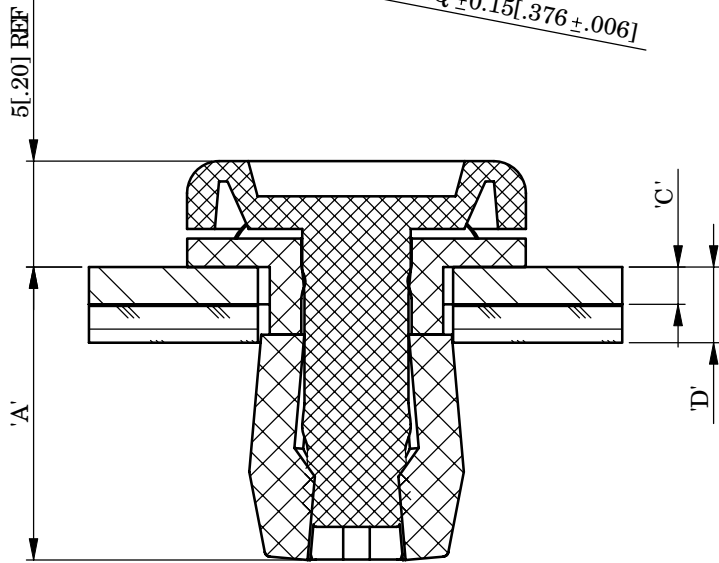
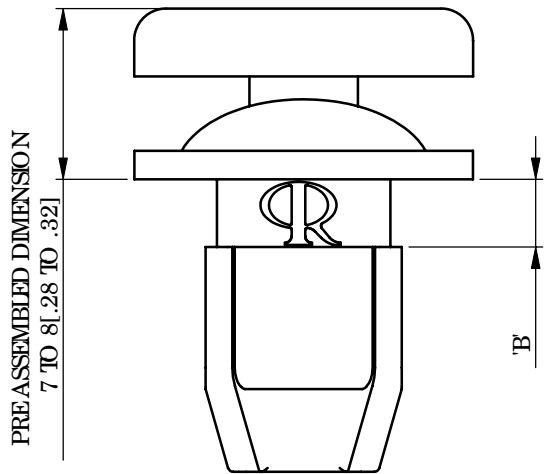
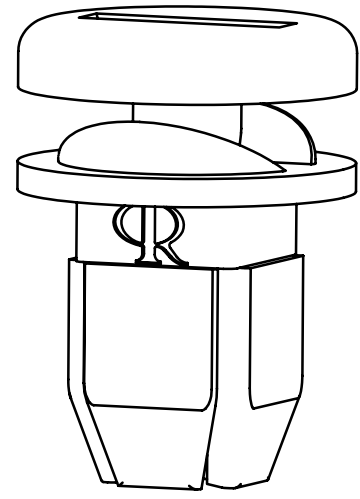
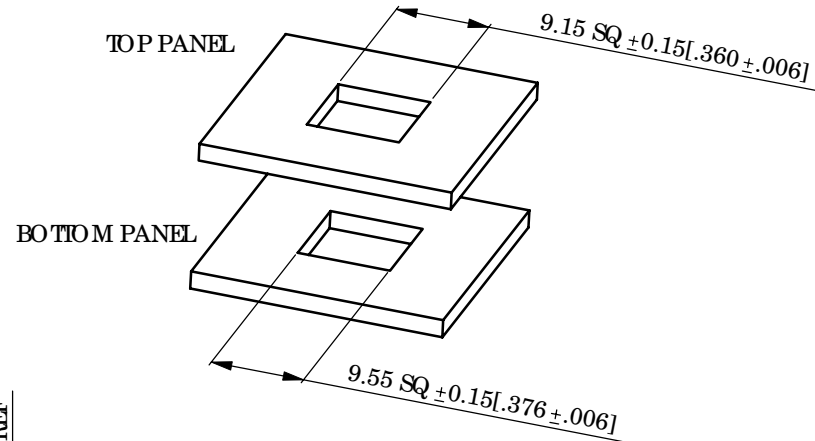
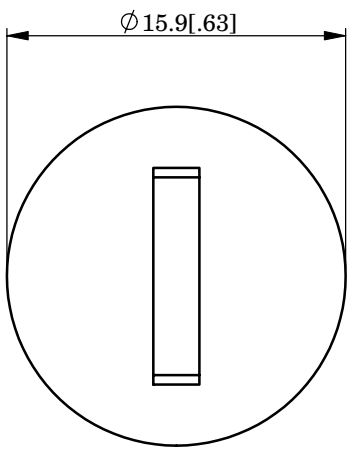

ALTERNATE UNITS FOR REFERENCE ONLY

INFORMATION CONTAINED IN THIS DOCUMENT IS CONFIDENTIAL TO RICHCO INTERNATIONAL Co., Ltd. AND MAY NOT BE DISCLOSED OR REPRODUCED IN WHOLE OR PART WITHOUT THEIR WRITTEN CONSENT

**RICHCO, INC.**  
 WWW.RICHCO-INC.COM

ALL DIMENSIONS IN mm  
 GENERAL TOLERANCES ±0.25  
 UNLESS OTHERWISE STATED  
 1 DECIMAL PLACE ±  
 2 DECIMAL PLACES ±  
 ANGULAR ±1°

THIRD ANGLE

PART NUMBER	'A'	'B'	TOP PANEL THICKNESS 'C'	TOTAL PANEL THICKNESS 'D'
QTPF-1BK	12.3 [.48]	1.7 [.07]	0.5 TO 1.6 [.020 TO .063]	2 TO 5 [.078 TO .196]
QTPF-2BK	13.7 [.54]	3.1 [.12]	1.8 TO 3.1 [.071 TO .122]	4 TO 6.2 [.157 TO .244]

MATERIAL: ACETAL- UL94 HB (RMS-14)		COLOUR: BLACK	
DESCRIPTION: QUARTER TURN PANEL FASTENER		PART No: SEE TABLE	
DRG No: 08-121		NPR No: GB08-0042	
SHEET SIZE A4			
DRN PH	DATE 17/12/08	CHKD TC	DATE 19/12/08
SCALE NTS	SHEET No. 1 OF 1		

AVAILABLE IN WHITE BY SPECIAL ORDER, TO ORDER REPLACE BK WITH WH

A B C D E F