

PART NO.	"A"
REHCBS-4-01	1/4 [6.4]
*REHCBS-5-01	5/16 [7.9]
REHCBS-8-01	1/2 [12.7]
*REHCBS-12-01	3/4 [19.1]

\*AVAILABLE BY SPECIAL ORDER ONLY.

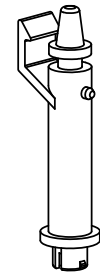
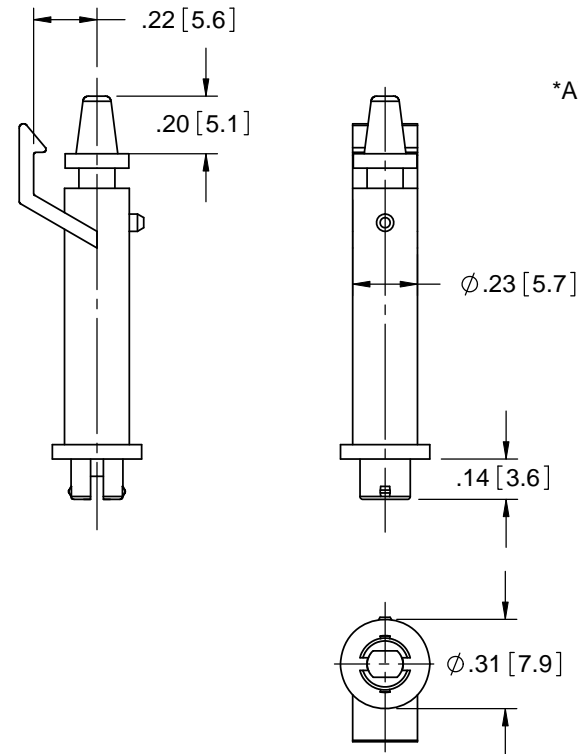
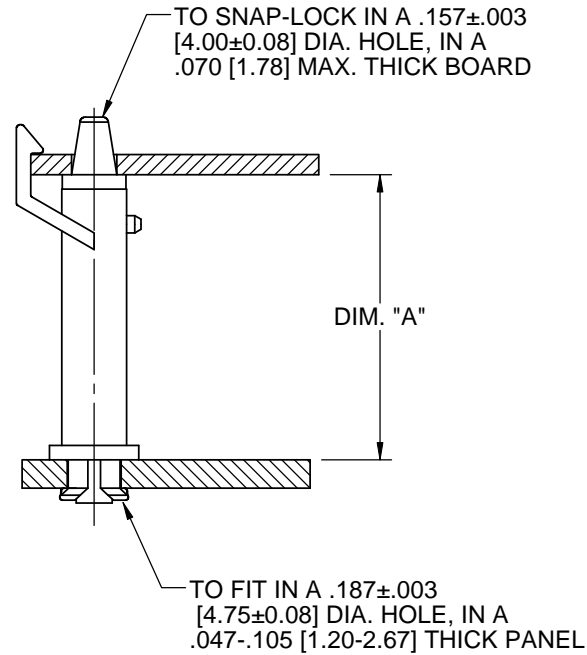

NOTES:  
 1. MATERIAL: NYLON 6/6 (RMS-01)  
 2. COLOR: NATURAL.

REV.			TITLE: RIVET EDGE HOLD CIRCUIT BOARD SUPPORT				DWG IN IN [MM]		FINAL	
L	SEE CO 200604 FOR CHANGES	SK	12/01/10	FILE #: REHCBS	DWN: SK	APP: -	PART #		PRINT TYPE	
K	UNOBSOLETE REHCBS-12, SEE CO 200571	SK	08/05/10	SHEET: 1 OF 1	SHEET SIZE: A	DT: 03/04/05				CHKD: -
J	SEE CO 200041 FOR CHANGES	SK	09/28/07	RE: RICHCO, INC.		RICHCO, INC. ENG@RICHCO-INC.COM (773) 539-4060		SEE TABLE		
I	SEE ECN #957 FOR CHANGES	SK	03/04/05							
-	SEE ENGINEERING FOR REV. A-H	--	----					CA		
REV.	DESCRIPTION	ENGR.	DATE							

CREATED USING  
 SOLIDWORKS  
 TOLERANCES  
 UNLESS NOTED  
 .XX=±.010  
 .XXX=±.005  
 FRAC.=±1/64  
 ANG.=±1°