

PART NO.	"A" DIA.	"B" DIA.	"C"	THREAD TYPE	PANEL THICKNESS
SEI-1	.39 [9.9]	.21 [5.3]	.30 [7.6]	#6-32 UNC	.050-.095 [1.27-2.41]
SEI-2				M4	.050-.091 [1.27-2.3]
SEI-3				M3	
SEI-4	.43 [10.9]	.25 [6.3]	.34 [8.6]	M5	.050-.095 [1.27-2.41]
SEI-5				M6	

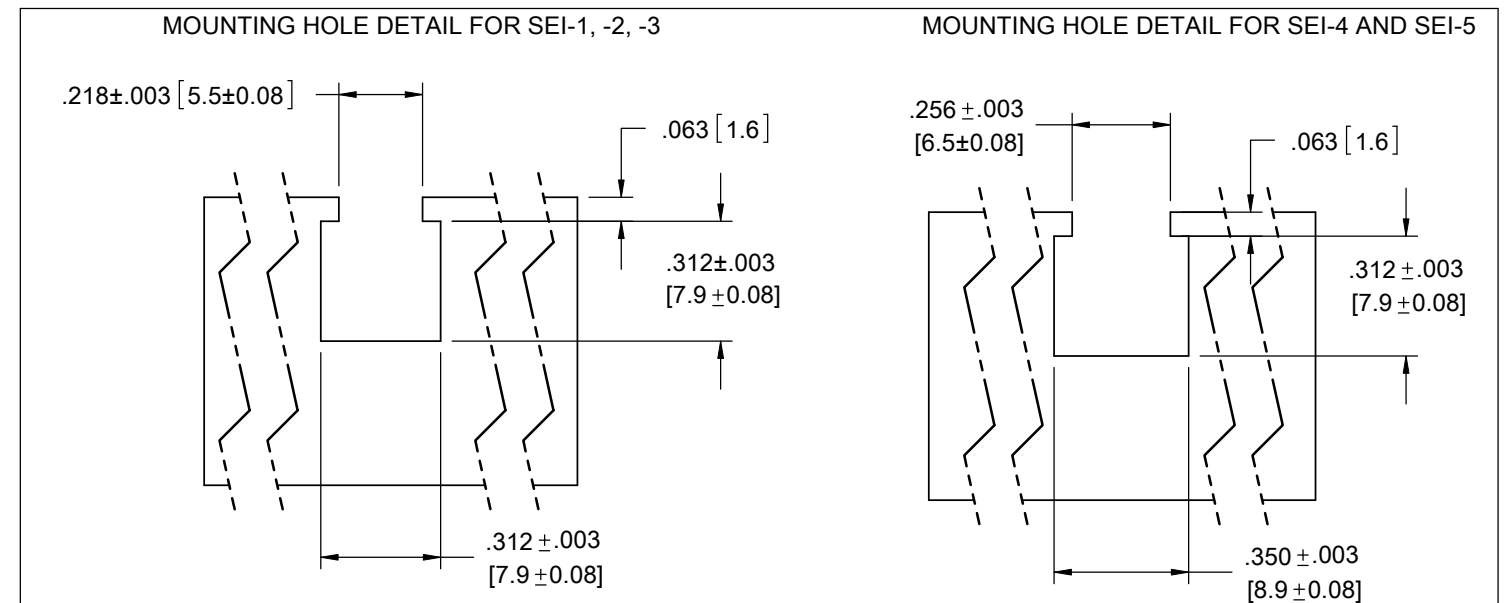
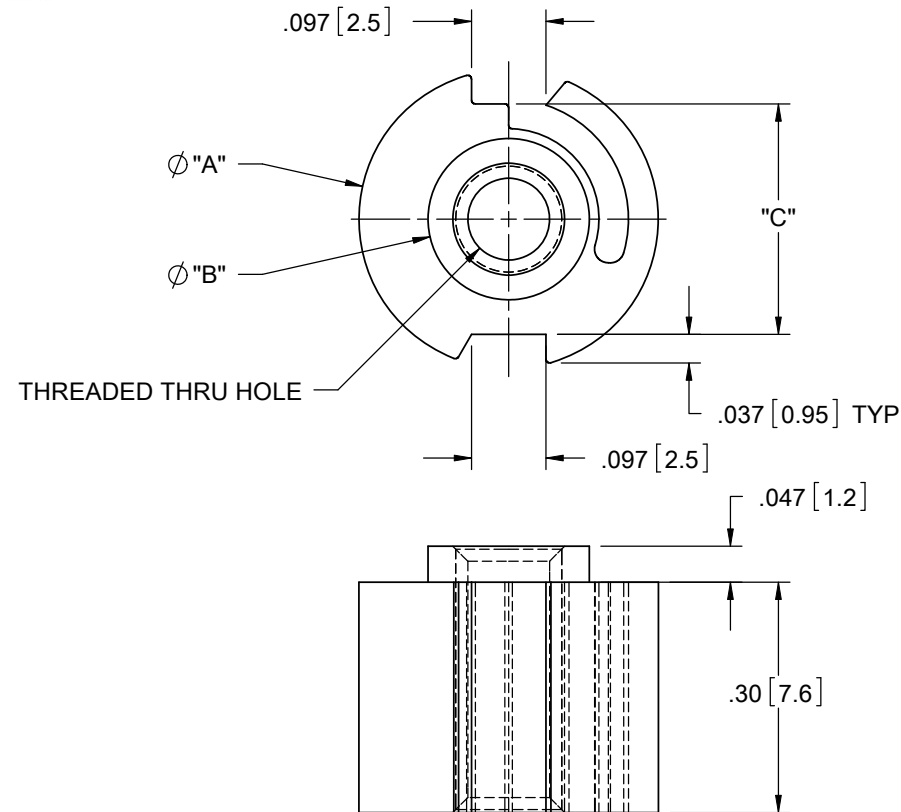
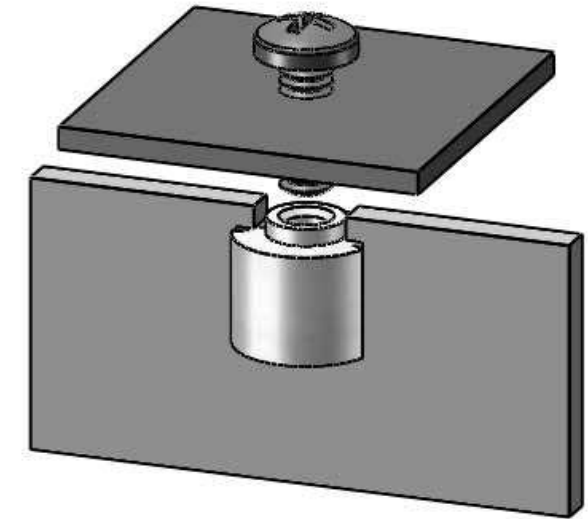

- NOTES:
 1. MATERIAL: NYLON UL 94 V-2 (RMS-01).
 - NYLON 6/6 UV STABILIZED (RMS-46), AVAILABLE BY SPECIAL ORDER.
 TO ORDER ADD SUFFIX "-UVB" AT THE END OF PART NO.
 -NYLON 6/6 UL94 V-2 (RMS-109), AVAILABLE BY SPECIAL ORDER.
 TO ORDER ADD SUFFIX "-HT" AT THE END OF PART NO.
 2. COLOR: BLACK.
 3. TOOL REQUIRED FOR SCREW INSTALLATION

REV.	DESCRIPTION	ENGR.	DATE
D	SEE CO 200550 FOR CHANGES	SK	07/01/10
C	SEE CO 200456 FOR CHANGES	SK	10/22/09
B	SEE CO 200402 FOR CHANGES	SK	07/30/09
A	RELEASED FOR PRODUCTION	SK	09/14/07

TITLE: SHEET EDGE INSERTS				DWG IN IN [MM]		FINAL	
CREATED USING SOLIDWORKS	FILE #: SEI-X	DWN: SK	APP: S.K.	PART #			
TOLERANCES UNLESS NOTED .XX=±.010 .XXX=±.005 FRAC.=±1/64 ANG.=±1°	SHEET: 1 OF 1 SHEET SIZE: B	DT: 09/12/07	CHKD: S.J.	SEE TABLE			
RE: RICHCO, INC.		RICHCO, INC. ENG@RICHCO-INC.COM (773) 539-4060		PRINT TYPE		CA	