

PART NO.	DIM "A" ±.015(0.4)	STUD LENGTH
SFCBS-M4-10M-01	.39 (10)	.31 (8)
SFCBS-M4-12M-01	.47 (12)	.39 (10)
SFCBS-M4-14M-01	.55 (14)	.47 (12)
SFCBS-M4-16M-01	.63 (16)	.55 (14)
SFCBS-M4-18M-01	.71 (18)	.63 (16)
SFCBS-M4-20M-01	.79 (20)	.71 (18)

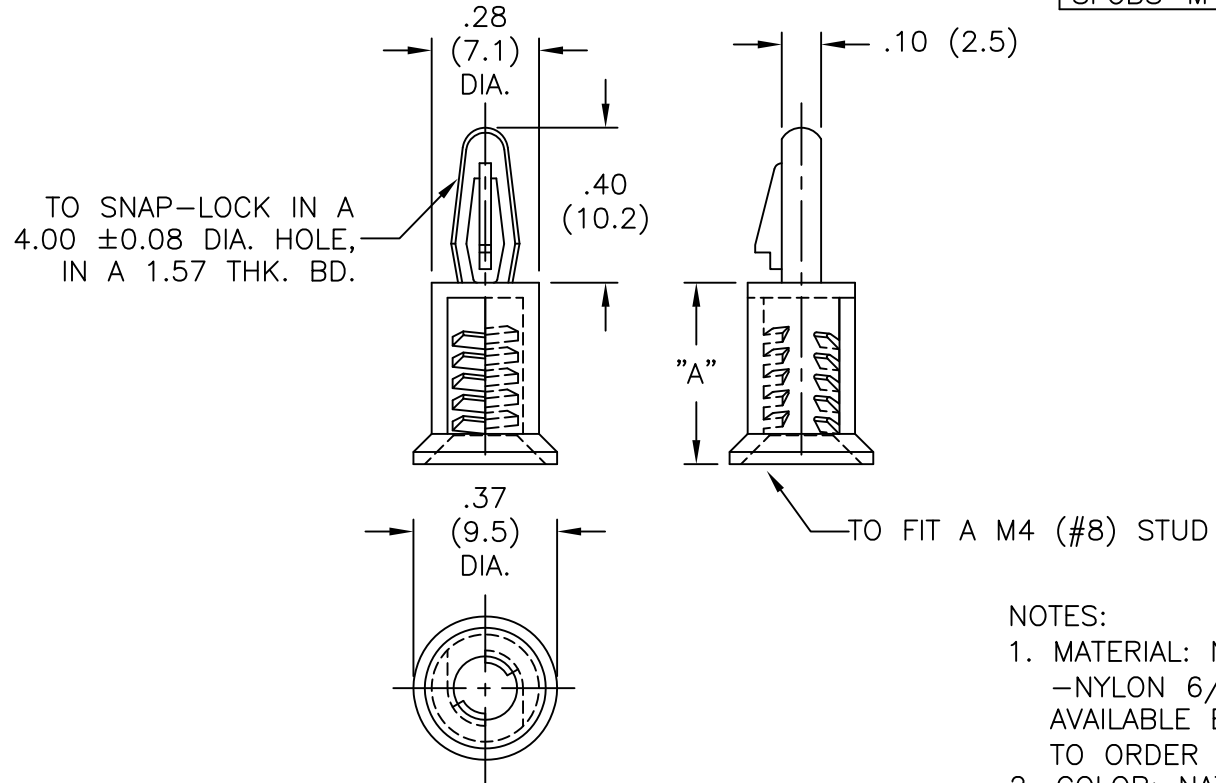

- NOTES:
- MATERIAL: NYLON 6/6 UL94 V-2 (RMS-01).
-NYLON 6/6 UL94 V-0 (RMS-19),
AVAILABLE BY SPECIAL ORDER ONLY.
TO ORDER REPLACE "-01" WITH "-19"
 - COLOR: NATURAL

<table border="1"> <tr> <td>C</td> <td>SEE CO 200407 FOR CHANGES</td> <td>SK 08.04.09</td> </tr> <tr> <td>B</td> <td>SEE CO 200404 FOR CHANGES</td> <td>SK 07.31.09</td> </tr> <tr> <td>A</td> <td>CHANGED FILE NO.AND TITLE BLOCK</td> <td>SM 05.10.01</td> </tr> <tr> <td>REV</td> <td>DESCRIPTION</td> <td>ENGR DATE</td> </tr> </table>			C	SEE CO 200407 FOR CHANGES	SK 08.04.09	B	SEE CO 200404 FOR CHANGES	SK 07.31.09	A	CHANGED FILE NO.AND TITLE BLOCK	SM 05.10.01	REV	DESCRIPTION	ENGR DATE	<table border="1"> <tr> <td colspan="4">TOLERANCES UNLESS NOTED .XX=±.010 .XXX=±.005 FRAC=±1/64 ANG=±1'</td> </tr> <tr> <td>FILE #</td> <td>SFCBS</td> <td>DWN:</td> <td>J.B.</td> </tr> <tr> <td>MAT'L:</td> <td>SEE NOTES</td> <td>DT:</td> <td>05-31-96</td> </tr> <tr> <td>RE:</td> <td>RICHCO, INC.</td> <td>DT:</td> <td></td> </tr> </table>				TOLERANCES UNLESS NOTED .XX=±.010 .XXX=±.005 FRAC=±1/64 ANG=±1'				FILE #	SFCBS	DWN:	J.B.	MAT'L:	SEE NOTES	DT:	05-31-96	RE:	RICHCO, INC.	DT:		<table border="1"> <tr> <td>APP:</td> <td></td> </tr> <tr> <td>DT:</td> <td></td> </tr> </table>		APP:		DT:		<table border="1"> <tr> <td>DWG IN IN (MM)</td> <td>FINAL</td> </tr> <tr> <td>PART #</td> <td>SEE TABLE</td> </tr> </table>		DWG IN IN (MM)	FINAL	PART #	SEE TABLE	<table border="1"> <tr> <td>PRINT TYPE</td> <td>CA</td> </tr> </table>	PRINT TYPE	CA
C	SEE CO 200407 FOR CHANGES	SK 08.04.09																																															
B	SEE CO 200404 FOR CHANGES	SK 07.31.09																																															
A	CHANGED FILE NO.AND TITLE BLOCK	SM 05.10.01																																															
REV	DESCRIPTION	ENGR DATE																																															
TOLERANCES UNLESS NOTED .XX=±.010 .XXX=±.005 FRAC=±1/64 ANG=±1'																																																	
FILE #	SFCBS	DWN:	J.B.																																														
MAT'L:	SEE NOTES	DT:	05-31-96																																														
RE:	RICHCO, INC.	DT:																																															
APP:																																																	
DT:																																																	
DWG IN IN (MM)	FINAL																																																
PART #	SEE TABLE																																																
PRINT TYPE	CA																																																
TITLE: STUD-FITTING CIRCUIT BOARD SUPPORT																																																	
			RICHCO INC. PO BOX 804238, CHICAGO, 60680 (773) 539-4060																																														