

PART NO.	MAT'L THK'NESS MAXIMUM
SLPA125-187-01	.187 (4.7)
SLPA125-250-01	.250 (6.4)
SLPA125-312-01	.312 (7.9)
SLPA125-375-01	.375 (9.5)
SLPA125-500-01	.500 (12.7)
SLPA125-625-01	.625 (15.9)
SLPA125-750-01	.750 (19.1)

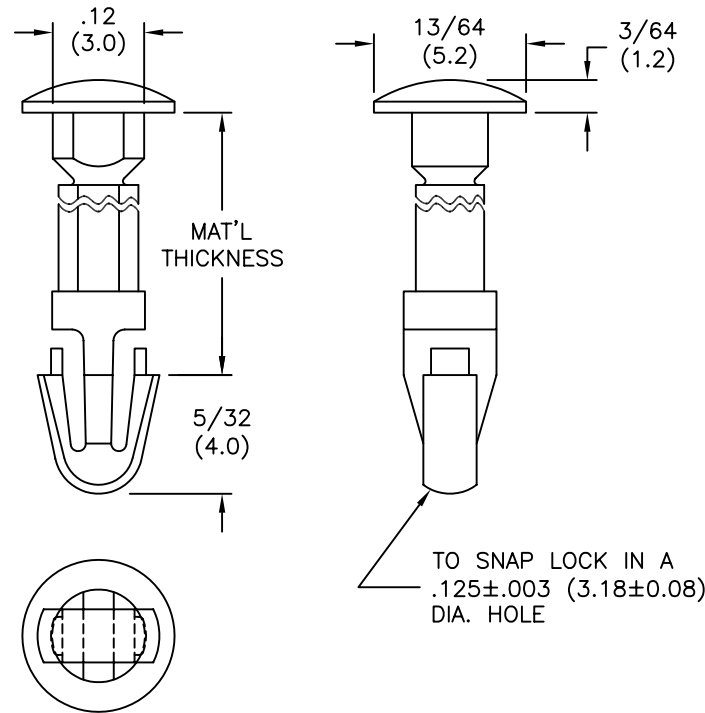

NOTE:

- MAT'L: NYLON 6/6 (RMS-01).
FLAME RETARDANT, NYLON (RMS-19),
AVAILABLE BY SPECIAL ORDER ONLY.
- COLOR: NATURAL.

B	ADDED NYLON 6/6; CHANGED FILE NO.	SM 02.21.02
A	MAT'L RMS-19 ADDED	J.L. 8.13.99
REV	DESCRIPTION	ENGR DATE

TITLE: SNAP LOCK PIN WITH ARROWHEAD				DWG IN IN (MM)		FINAL		PRINT TYPE	
TOLERANCES UNLESS NOTED .XX=±.020 .XXX=±.015 FRAC=±1/64 ANG=±1°		FILE # SLPA125	DWN: J.B.	APP:	PART #		PRINT TYPE		
		MAT'L: SEE NOTES	DT: 12-05-95	DT:	SEE TABLE		CA		
		RE: RICHCO, INC.	RICHCO INC. PO BOX 804238, CHICAGO, 60680 (773) 539-4060						