

PART NO.	"A"
SN-125	$\pm .015(0.4)$ 1/8 (3.2)
SN-187	3/16 (4.8)
SN-250	1/4 (6.4)
SN-312	5/16 (7.9)
SN-375	3/8 (9.5)
SN-500	1/2 (12.7)

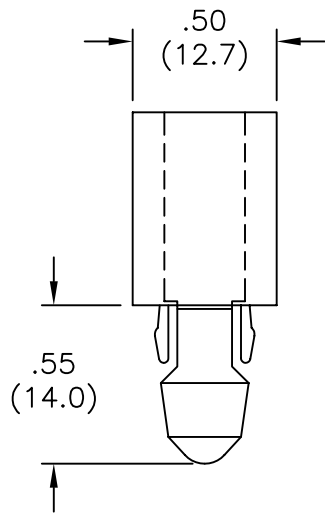

TO FIT IN A .312 (7.9) SQUARE HOLE, 1/16 (1.6) NOM. BD. THICKNESS

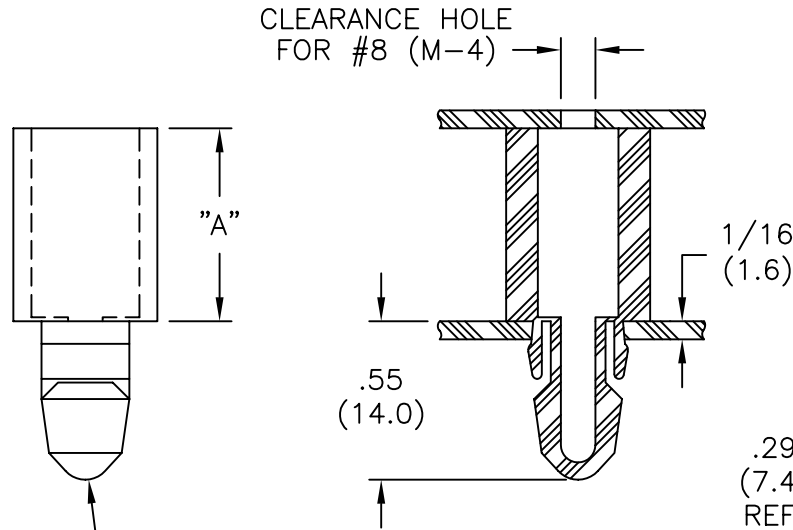

TYPICAL APPLICATION

NOTES:

- MAT'L: POLYCARBONATE (RMS-03)
COLOR: CLEAR

REV	DESCRIPTION	ENGR	DATE
B	CHANGED FILE NO. AND TITLE BLOCK	SM	05.16.01
A	.29 DIM WAS .41	JB	05.15.96

TITLE: SPACER NUT				DWG IN IN (MM)	FINAL
TOLERANCES UNLESS NOTED .XX=±.010 .XXX=±.005 FRAC=1/64 ANG=1°	FILE # SN	DWN: P.B.	APP:	PART #	
	MAT'L: SEE NOTES	DT: 07-12-94	DT:	SEE TABLE	
	RE: RICHCO, INC.	RICHCO INC. PO BOX 804238, CHICAGO, 60680 (773) 539-4060		PRINT TYPE CA	