

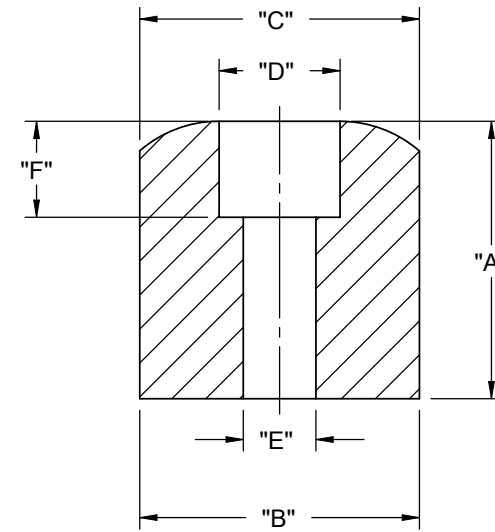

PART NO.	"A"	DIA. "B"	DIA. "C" REF	DIA. "D"	DIA. "E"	"F"	STYLE
SOF-15129	7.1 [.28]	15.9 [.63]	13.8 [.54]	8 [.31]	3.2 [.13]	4 [.16]	1
SOF-15140	9.5 [.37]	17.5 [.69]	--	8 [.31]	4 [.16]	5.2 [.20]	2
SOF-15125	11.5 [.45]	19.1 [.75]	18 [.71]	10.2 [.40]	5 [.20]	6.35 [.25]	1
SOF-15111	15.25 [.60]	19 [.75]	12.7 [.50]	8 [.31]	4 [.16]	4.8 [.19]	2
SOF-15127	18.35 [.72]	18.5 [.73]	---	8 [.31]	4.8 [.19]	6.35 [.25]	1
SOF-15126	25 [.98]	22.5 [.89]	12.7 [.50]	8.7 [.34]	4 [.16]	14.5 [.57]	2

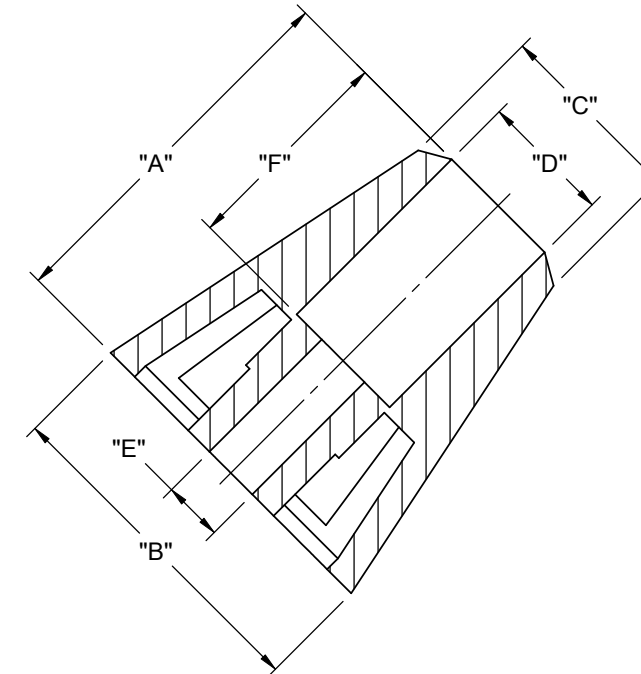

SECTION A-A  
SCALE 2 : 1



SECTION B-B  
SCALE 2 : 1

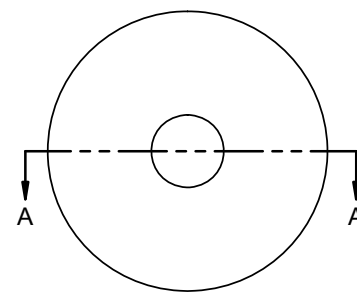

STYLE 1

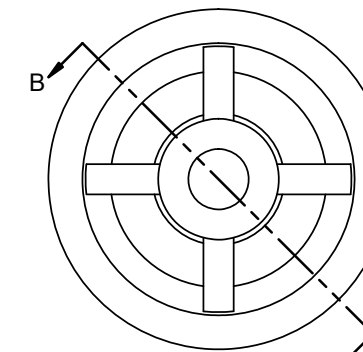

STYLE 2

NOTES:  
 1. MATERIAL: NEOPRENE RUBBER (RMS-190)  
 2. COLOR: BLACK  
 3. ALTERNATE UNITS FOR REFERENCE ONLY

REV.	DESCRIPTION	ENGR.	DATE
I	SEE CO 200330 FOR CHANGES	SK	02/20/09
H	SEE ECN #1298 FOR CHANGES	SK	03/16/07
G	SEE ECN #1294 FOR CHANGES	SK	03/07/07
F	SEE ECN #1257 FOR CHANGES	SK	12/05/06
E	REDRAWN, SEE ECN #1225 FOR CHANGES	SK	09/28/06

TITLE: <b>SCREW ON FEET</b>		DWG IN mm [IN]		FINAL	
CREATED USING SOLIDWORKS	FILE #: SOF	DWN: SK	APP: SK	PART #	
GENERAL TOLERANCE UNLESS OTHERWISE NOTED ±0.25 ANG.=±1°	SHEET: 1 OF 1   SHEET SIZE: B	DT: 08/31/06	CHKD: D.J.Z.	SEE TABLE	
RE: RICHCO, INC.		RICHCO, INC. ENG@RICHCO-INC.COM (773) 539-4060		PRINT TYPE <b>CA</b>	