

AVAILABLE BY SPECIAL ORDER- NAFTA REGION ONLY

REV.	MODIFICATION.	DATE	DRN
03	ECN-05-081	26/07/05	NJB
04	ECN-07-193	08/11/07	SF
05	CO-2010035	08/02/08	TC
06	CO-2010578	24/02/09	TC
07	CO-2010636	27/04/09	SF
08	CO-2010649	28/07/09	OW

PART NO.	M	H	T	L																																								
TCBN-T1-M3-6-L	M3	6.0 [.237]	1.6 [.063]	5.0 [.197]	6.0 [.236]	7.0 [.276]	8.0 [.315]	9.0 [.355]	10.0 [.394]	11.0 [.434]	12.0 [.473]	13.0 [.512]	14.0 [.552]	15.0 [.591]	16.0 [.630]	17.0 [.670]	18.0 [.709]	19.0 [.749]	20.0-61.0 [.788-2.402]																									
TCBN-T1-M3-8-L		8.0 [.315]																																										
TCBN-T2-M3-6-L		6.0 [.237]	2.0 [.079]																																									
TCBN-T2-M3-8-L		8.0 [.315]																																										
TCBN-T1-M4-8-L	M4	8.0 [.315]	1.6 [.063]																																									
TCBN-T2-M4-8-L		8.0 [.315]	2.0 [.079]																																									
																				1+1-0.5 [.118]	3.0 [.158]	4.0 [.178]	5.0 [.236]	6.0 [.276]	7.0 [.315]	8.0 [.355]	9.0 [.394]	10.0 [.394]																

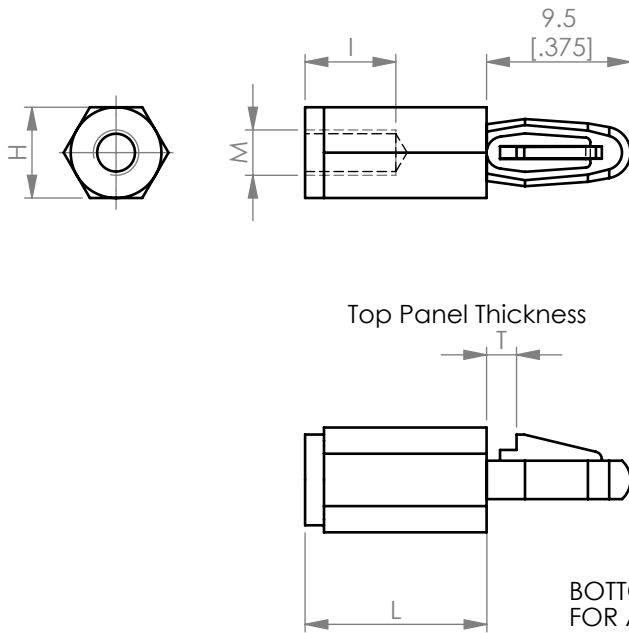

TOP PCB -  
MOUNTING  
HOLE DIA  
4 +/- 0.08  
[.158 +/- .003]

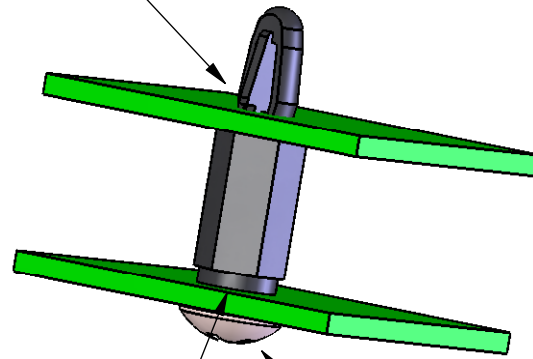

BOTTOM PCB MOUNTING HOLE  
FOR ANY PANEL THICKNESS:  
DIA 3.2 [.125] FOR M3 SCREW  
DIA 4.8 [.188] FOR M4 SCREW

FIXING SCREW  
NOT SUPPLIED

NOTES:

- 1) ALL PRIMARY DIMENSIONS IN mm, SECONDARY DIMENSIONS IN [INCHES].
- 2) LENGTHS AVAILABLE IN INCREMENTS OF 1mm.

INFORMATION CONTAINED IN THIS DOCUMENT IS CONFIDENTIAL TO RICHCO INTERNATIONAL Co. Ltd. AND MAY NOT BE DISCLOSED OR REPRODUCED IN WHOLE OR PART WITHOUT THEIR WRITTEN CONSENT

**RICHCO, INC.**  
WWW.RICHCO-INC.COM

METRIC GENERAL TOLERANCES ±0.25  
ARE PRIMARY UNLESS OTHERWISE STATED  
1 DECIMAL PLACE ±  
2 DECIMAL PLACES ±  
ANGULAR ±1°

IMPERIAL GENERAL TOLERANCES ±0.010  
ARE FOR REFERENCE UNLESS OTHERWISE STATED  
1 DECIMAL PLACE ±  
2 DECIMAL PLACES ±  
ANGULAR ±1°

MATERIAL:  
NYLON 6/6 (RMS-172)

COLOUR:  
BLACK

TITLE: THREADED CIRCUIT BOARD  
SUPPORT, NYLON

PART No:  
TCBN-TX-MD-H-L

DRG No:  
04-133

NPR REF:

SIZE  
A4

DRN  
NJB

DATE  
26/10/04

CHKD  
RC

DATE  
26/10/04

SCALE  
NTS

SHEET No  
1 OF 1