

PART NO.	MAX BUNDLE DIA.	"L" LENGTH APPROX.	"W" WIDTH REF	"T" THICKNESS REF	"A"	"B"	MIN LOOP TENSILE
WIT-50SR	1-1/2 [38.1]	6 [152.4]	.19 [4.8]	.05 [1.3]	.21 [5.3]	.31 [7.9]	50 lbf [22.7kgf]
WIT-50RR	2 [50.8]	8 [203.2]			.22 [5.6]	.34 [8.6]	
WIT-50LR	3 [76.2]	11-21/32 [295.9]					

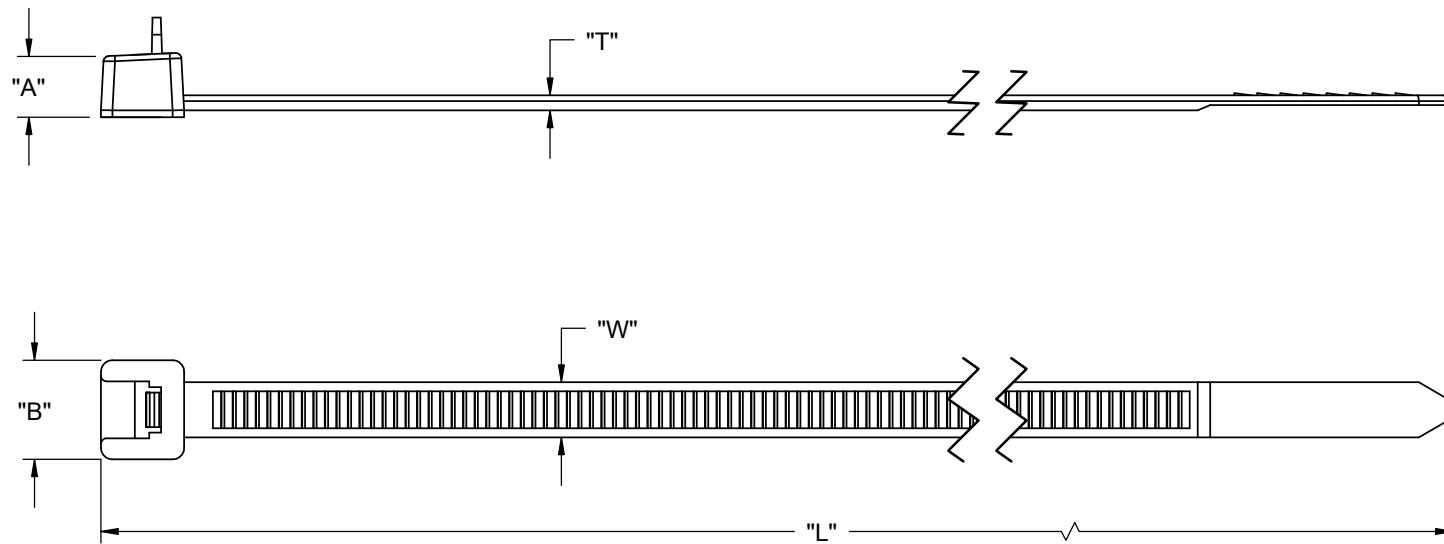

- NOTES:
- MATERIAL: NYLON 6/6 UL 94 V-2 (RMS-01).
COLOR: NATURAL.
 - MATERIAL: UV STABILIZED NYLON 6/6 UL 94 V-2 (RMS-46).
COLOR BLACK.
TO ORDER USE P/N: WIT-50XX-UVB.
 - MATERIAL: NYLON 6/6 UL 94 V-0 (RMS-75), COLOR NATURAL.
AVAILABLE BY SPECIAL ORDER ONLY.
TO ORDER USE PART P/N: WIT-50XX-V0
 - COLORS: GREEN (-GN), BLUE (-BL), YELLOW (-YL)
AND RED (-RD) AVAILABLE BY SPECIAL ORDER ONLY.
TO ORDER ADD COLOR SUFFIX TO PART NO.
 - PACKAGING QUANTITIES ARE REFLECTED AS THE SUFFIX "-LETTER".
EXAMPLE: WIT-50RR-UVB-M FOR 1000 PCS PER BAG.
-C = 100 PCS
-M = 1000 PCS
-XL = NO LABEL

REV.	DESCRIPTION	ENGR.	DATE
G	ADDED NOTE 4. SEE CO 200661 FOR CHANGES	SK	05/12/11
F	SEE CO 200557 FOR CHANGES	SK	07/19/10
E	SEE CO 200161 FOR CHANGES	SK	04/15/08
D	REDRAWN, SEE CO 200085 FOR CHANGES	SK	12/07/07
-	SEE ENGINEERING FOR REV A-C	---	-----

TITLE: RELEASABLE WIRE TIES		DWG IN IN [MM]		FINAL	
CREATED USING SOLIDWORKS	FILE #: WIT-XXXXR	DWN: S.K.	APP: D.Z.	PART #	
TOLERANCES UNLESS NOTED .XX=±.010 .XXX=±.005 FRAC.=±1/64 ANG.=±1°	SHEET: 1 OF 1 SHEET SIZE: B	DT: 12/07/07	CHKD: R.T.	SEE TABLE	
RE: RICHCO INC.	RICHCO, INC. ENG@RICHCO-INC.COM (773) 539-4060		PRINT TYPE		CA