



THREE FLANGE SINGLE PRIMARY 1.1VA PC BOARD POWER TRANSFORMER

MODEL NUMBER
3FS-2XX & PSS2-XX

REV. Status
REVISION - 05/08/96 TS
REVISION A REFORMATTED 08/14/96 TS
REVISION B REFORMATTED 08/20/96 TS
REVISION C REFORMATTED 07/14/97 TS
REVISION D CHANGED A.7. 08/23/99 TS
REVISION E ADDED RoHS 01/12/06 MP

A. Electrical Specifications (@ 25°C)

1. Maximum Power: 1.1 VA
2. Input Voltage and Frequency: 115V 50/60 Hz
3. Secondary Voltage: See Table A
4. Voltage Regulation: 24% TYP @ full load to no load
5. Temperature Rise: 35°C TYP (45°C MAX allowed)
6. Insulation Resistance:
100 MΩ MIN @ 500VDC, Pri to Sec, Pri to Core
100 MΩ MIN @ 500VDC, Sec to Core
7. Hi-Pot: 2500 Vrms 1 minute @ Pri to Sec
1500 Vrms 1 minute @ Pri to Core
1500 Vrms 1 minute @ Sec to Core
500 Vrms 1 minute @ Sec to Sec



B. Marking: TAMURA, Tamura part number (see sheet 2), MICROTRAN, Microtran part number (see sheet 2), date code, country of origin, safety logos and input and output ratings

C. Safety:

- Insulation Class B (130°C) File No. E92957
- CSA 22.2 Nos. 0 and 66, File No. LR69808
- UL 1585, Class II and III, File No. E95844
- UL 506, General Purpose, File No. E91239



D. Mechanical Specifications:

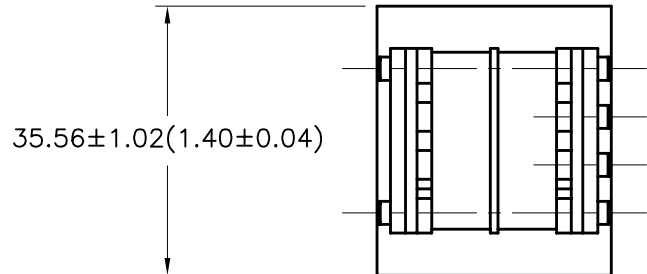
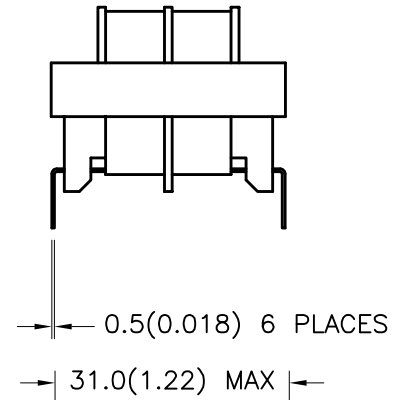
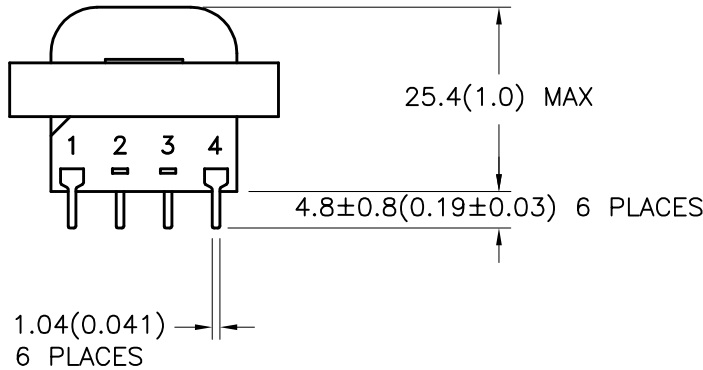
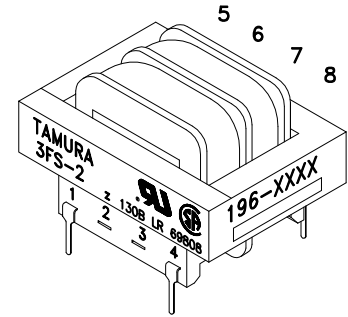

PREPARED BY: K. BRENNAN
ENGINEER: M. PITCHAI
QUALITY CONTROL: T. CLEM
APPROVED: Y. SEKIGUCHI

DWG CONTROL NO. P-A1-11031 ACAD\3F\A1113011.DWG	REV E	SIZE 2 3FS & PSS FAMILY POWER TRANSFORMER
TAMURA CORPORATION OF AMERICA 43352 BUSINESS PARK DRIVE, TEMECULA, CA. 92590-6624 (951) 699-1270 FAX 9516769482		

3FS-2XX & PSS2-XX		
MODEL SPECIFICATION		
DIM: mm(In)	SCL: 1/1	SH: 1 OF 2

PROPRIETARY NOTICE: THIS DRAWING PRINT OR DOCUMENT AND SUBJECT MATTER DISCLOSED HEREIN ARE PROPRIETARY ITEMS TO WHICH TAMURA RETAINS THE EXCLUSIVE RIGHT OF DISSEMINATION, REPRODUCTION, MANUFACTURE AND SALE. THIS DRAWING, PRINT OR DOCUMENT IS SUBMITTED IN CONFIDENCE FOR CONSIDERATION BY THE RECIPIENT ALONE UNLESS PERMISSION FOR FURTHER DISCLOSURE IS EXPRESSLY GRANTED IN WRITING.



E. Mounting Footprint:

REV. Status
REVISION - 05/08/96 TS
REVISION A REFORMATTED 08/14/96 TS
REVISION B REFORMATTED 08/20/96 TS
REVISION C REFORMATTED 07/14/97 TS
REVISION D CHANGED A.7. 08/23/99 TS
REVISION E ADDED RoHS 01/12/06 MP



MODEL NUMBER
3FS-2XX & PSS2-XX

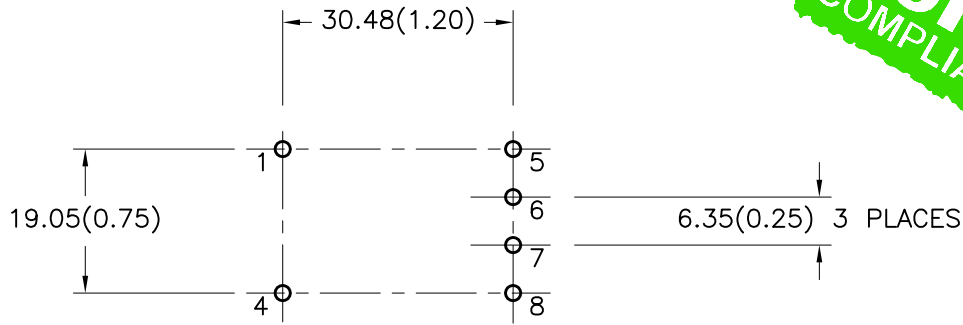

F. Schematic Diagram:

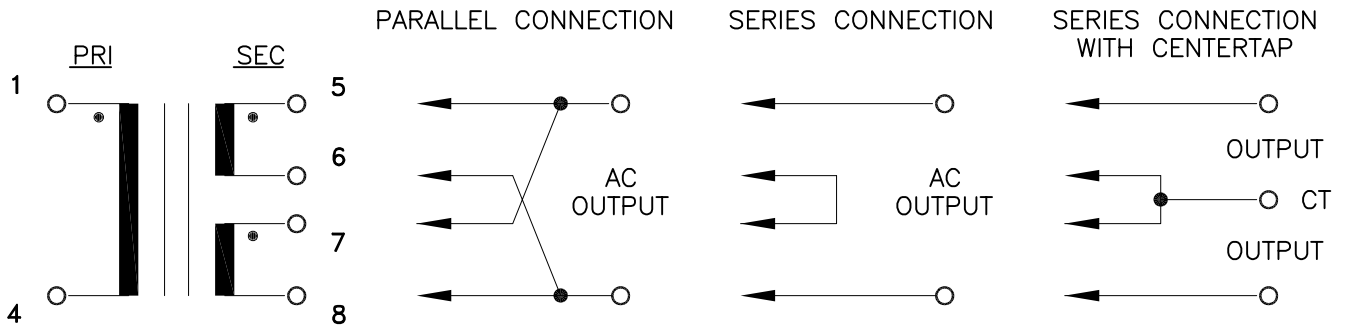

G. Table A: (NOTE: All parts are dual marked with both part numbers)

TAMURA PART NO.	MICROTRAN PART NO.	PARALLEL CONNECTION		SERIES CONNECTION		SERIES CONNECTION WITH CT	
		AC VOLTS	RMS AMPS	AC VOLTS	RMS AMPS	AC VOLTS	RMS AMPS
3FS-210	PSS2-10	5.0	0.220	10.0	0.110	5.0-CT-5.0	0.110
3FS-212	PSS2-12	6.3	0.180	12.6	0.090	6.3-CT-6.3	0.090
3FS-216	PSS2-16	8.0	0.140	16.0	0.070	8.0-CT-8.0	0.070
3FS-220	PSS2-20	10.0	0.110	20.0	0.055	10.0-CT-10.0	0.055
3FS-224	PSS2-24	12.0	0.090	24.0	0.045	12.0-CT-12.0	0.045
3FS-228	PSS2-28	14.0	0.080	28.0	0.040	14.0-CT-14.0	0.040
3FS-236	PSS2-36	18.0	0.060	36.0	0.030	18.0-CT-18.0	0.030
3FS-248	PSS2-48	24.0	0.046	48.0	0.023	24.0-CT-24.0	0.023
3FS-256	PSS2-56	28.0	0.040	56.0	0.020	28.0-CT-28.0	0.020
3FS-2120	PSS2-120	60.0	0.020	120.0	0.010	60.0-CT-60.0	0.010

PREPARED BY:
K. BRENNAN

ENGINEER:
M. PITCHAI

QUALITY CONTROL:
T. CLEM

APPROVED:
Y. SEKIGUCHI

DWG CONTROL NO. P-A1-11031
ACAD\3F\A1113012.DWG
REV E

SIZE 2 3FS & PSS FAMILY
POWER TRANSFORMER

TAMURA CORPORATION OF AMERICA
43352 BUSINESS PARK DRIVE, TEMECULA, CA. 92590-6624
(951) 699-1270 FAX 9516769482

3FS-2XX & PSS2-XX

MODEL SPECIFICATION
DIM: mm(In) SCL: 1/1 SH: 2 OF 2

PROPRIETARY NOTICE: THIS DRAWING PRINT OR DOCUMENT AND SUBJECT MATTER DISCLOSED HEREIN ARE PROPRIETARY ITEMS TO WHICH TAMURA RETAINS THE EXCLUSIVE RIGHT OF DISSEMINATION, REPRODUCTION, MANUFACTURE AND SALE. THIS DRAWING, PRINT OR DOCUMENT IS SUBMITTED IN CONFIDENCE FOR CONSIDERATION BY THE RECIPIENT ALONE UNLESS PERMISSION FOR FURTHER DISCLOSURE IS EXPRESSLY GRANTED IN WRITING.