

Hall Effect Current Sensors S23P***D15 Series

Features:

- Closed Loop type
- Current or voltage output
- Conversion ratio $K_N = 1:2000$
- Printed circuit board mounting
- Integrated primary
- Insulated plastic case according to UL94V0
- UL Recognition

Advantage:

- Excellent accuracy and linearity
- Low temperature drift
- Wide frequency bandwidth
- No insertion loss
- High Immunity to external interferences
- Optimised response time
- Current overload capability



Specifications

 $T_A=25^{\circ}\text{C}, V_{CC}=\pm 15\text{V}$

Parameters	Symbol	S23P50/100D15	
Primary nominal current	I_f	50A	100A
Maximum current ¹ (at 85°C)	I_{fmax}	$\pm 110\text{A}$ (at $R_M \leq 71\Omega$)	$\pm 160\text{A}$ (at $R_M \leq 25\Omega$)
Measuring resistance ($I_f = \pm A_{DC}$ at 85°C)	R_M	0Ω~217Ω (at $V_{CC} = \pm 12\text{V}$) 0Ω~327Ω (at $V_{CC} = \pm 15\text{V}$)	0Ω~57Ω (at $V_{CC} = \pm 12\text{V}$) 45Ω~114Ω (at $V_{CC} = \pm 15\text{V}$)
Conversion Ratio	K_N	1 : 2000	1 : 2000
Rated output current	I_o	25mA	50mA
Output current accuracy ² (at I_f)	X	$I_o \pm 0.25\%$	
Offset current ³ (at $I_f=0\text{A}$)	I_{of}	$\leq \pm 0.15\text{mA}$	
Output linearity ² (0A~ I_f)	ϵ_L	$\leq \pm 0.15\%$ (at I_f)	
Power supply voltage ¹	V_{CC}	$\pm 12\text{V} \dots \pm 15\text{V} \pm 5\%$	
Consumption current	I_{CC}	$\leq \pm 16\text{mA}$ (Output current is not included)	
Response time ⁴	t_r	$\leq 0.5\mu\text{s}$ (at $di/dt = 100\text{A} / \mu\text{s}$)	
Thermal drift of gain ⁵	T_{clo}	$\leq \pm 0.01\%/^{\circ}\text{C}$	
Thermal drift of offset current	T_{clof}	$\leq \pm 0.5\text{mA max.}$ (at $T_A = -25^{\circ}\text{C} \leftrightarrow +85^{\circ}\text{C}$)	
Hysteresis error	I_{OH}	$\leq 0.3\text{mA}$ (at $I_f=0\text{A} \rightarrow I_f \rightarrow 0\text{A}$)	
Insulation voltage	V_d	AC5000V, for 1minute (sensing current 0.5mA), Primary \leftrightarrow Secondary	
Insulation resistance	R_{IS}	$\geq 500\text{M}\Omega$ (at DC500V) Primary \leftrightarrow Secondary	
Secondary coil resistance	R_S	115Ω (at $T_A = 70^{\circ}\text{C}$) 121Ω (at $T_A = 85^{\circ}\text{C}$)	
Ambient operation temperature	T_A	$-40^{\circ}\text{C} \sim +85^{\circ}\text{C}$	
Ambient storage temperature	T_S	$-40^{\circ}\text{C} \sim +90^{\circ}\text{C}$	

¹ At $V_{CC}=\pm 15\text{V}$, I_{fmax} Operating Time: ≤ 10 Seconds. Maximum current is restricted by V_{CC} — ² Without offset current — ³ After removal of core hysteresis — ⁴ Time between 90% input current full scale and 90% of sensor output full scale — ⁵ Without Thermal drift of offset current

Electrical Performances

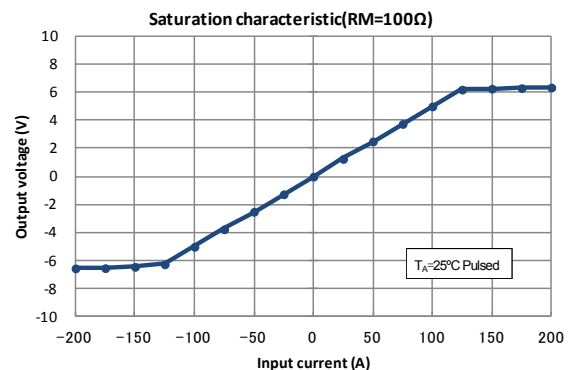
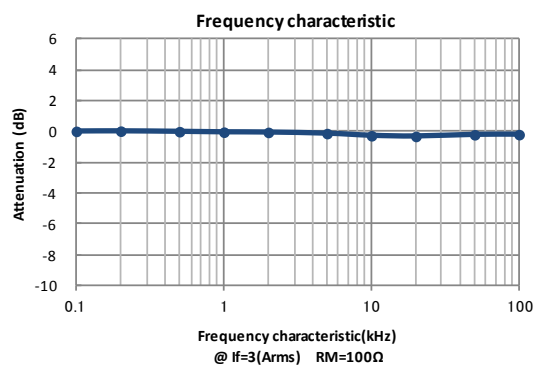

Hall Effect Current Sensors S23P***D15 Series

Mechanical dimensions

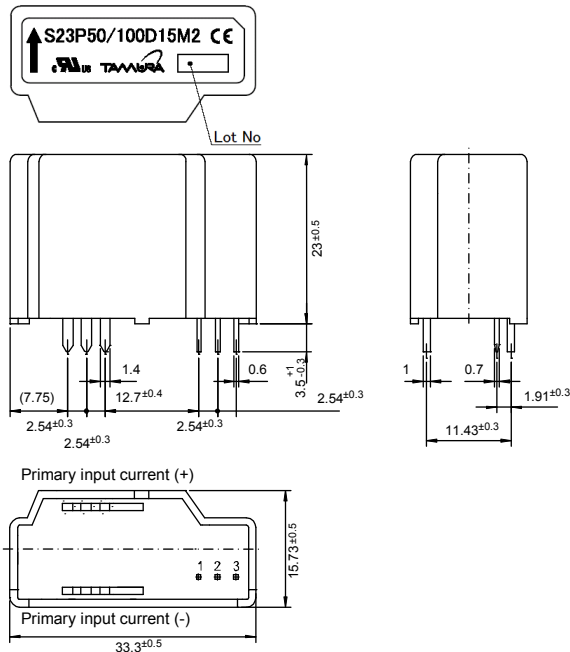

NOTES

1. Unit is mm
2. Tolerance is 0.5mm

Terminal number:

1. -V_{CC}(-15V)
2. +V_{CC}(+15V)
3. I_{OUT}

Connection specific

1. The primary connection
6Pins 1.4×1mm
Recommended PCB hole diameter:Φ2mm
2. The secondary connection
3Pins 0.7×0.6mm
Recommended PCB hole diameter:Φ1.2mm

Electrical connection diagram

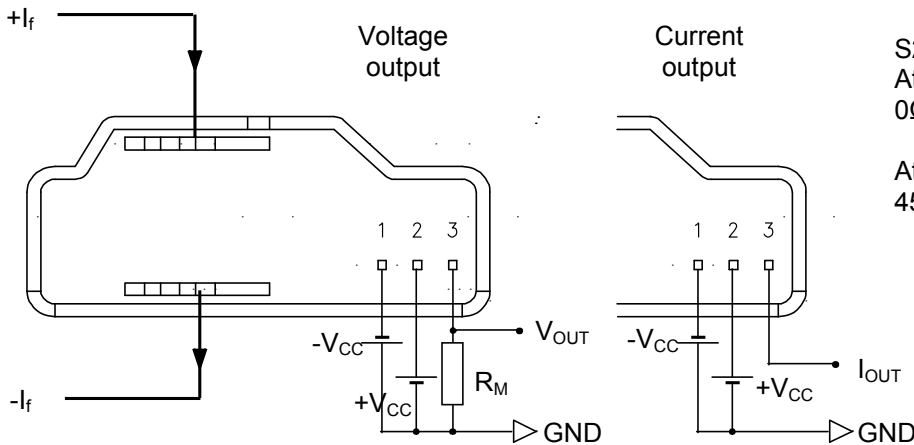

S23PxxxD15
At $I_f = 50A$ & $V_{CC} = \pm 15V_{DC}$
 $0\Omega \leq R_M \leq 327\Omega$

At $I_f = 100A$ & $V_{CC} = \pm 15V_{DC}$
 $45\Omega \leq R_M \leq 114\Omega$

UL Standard

- UL 508 , CSA C22.2 No.14 (UL FILE No.E243511)
- For use in Pollution Degree 2 Environment.
- Maximum Surrounding air temperature rating, 85°C.

CAUTION

Provide two min. 100 by 85 mm, 0.5 mm thick copper conductor-cum-heat sink as primary conductor of each side for safe usage. The primary conductor temperature and PCB should not exceed 100°C.

Package & Weight Information

Weight	Pcs/box	Pcs/carton	Pcs/pallet
26g	100	400	9600