

# Hall Effect Current Sensors L05Z\*\*\*S15 Series



## Features:

- Open Loop type
- Panel mounting
- Unipolar power supply
- Industrial temperature range
- JST connector
- Insulated plastic case according to UL94V0

## Advantage:

- Excellent accuracy and linearity
- Low temperature drift
- Wide frequency bandwidth
- No insertion loss
- High Immunity to external Interference
- Current overload capability

## Specifications

$T_A=25^{\circ}\text{C}$ ,  $V_{CC}=+15\text{V}$ ,  $R_L=10\text{k}\Omega$

Parameters	Symbol	L05Z800S15
Rated Current	$I_f$	800A
Saturation Current	$I_{fmax}$	$>\pm 900\text{A}$
Output Voltage	$V_{OUT}$	$V_{OE}+4\text{V} @ I_f$
Offset Voltage	$V_{OE}$	$+7.0\text{V}\pm 50\text{mV}$
Accuracy <sup>1</sup>	$X$	$\pm 1\% @ I_f$
Output Linearity <sup>1</sup>	$\epsilon_L$	$\pm 1\% @ 0\text{A}\sim I_f$
Supply Voltage	$V_{CC}$	$+15\text{V}\pm 5\%$
Consumption Current	$I_c$	$\leq 20\text{mA}$
Response Time	$t_r$	$\leq 10\mu\text{s} (@ di/dt=I_f/\mu\text{s})$
Output Temperature Characteristic <sup>1</sup>	$TCV_{OUT}$	$\pm 0.1\%/^{\circ}\text{C}$
Offset Temperature Characteristic	$TCV_{OE}$	$\pm 1.0\text{mV}/^{\circ}\text{C} @ I_f=0\text{A}$
Hysteresis allowance	$V_{OH}$	$\leq 20\text{mV} (@ 0\text{A} \leftrightarrow I_f)$
Insulation Withstanding	$V_d$	AC2500V, for 1minute (sensing current 0.5mA), inside of through hole $\leftrightarrow$ terminal
Insulation Resistance	$R_{IS}$	$\geq 500\text{M}\Omega$ (at DC500V) inside of through hole $\leftrightarrow$ terminal
Frequency Bandwidth <sup>2</sup>	$f$	DC .. 50kHz
Operating Temperature	$T_A$	$-40^{\circ}\text{C}\sim +85^{\circ}\text{C}$
Storage Temperature	$T_S$	$-40^{\circ}\text{C}\sim +85^{\circ}\text{C}$

<sup>1</sup> Without offset — <sup>2</sup> Small signal only to avoid excessive heating of magnetic core

## Electrical Performances

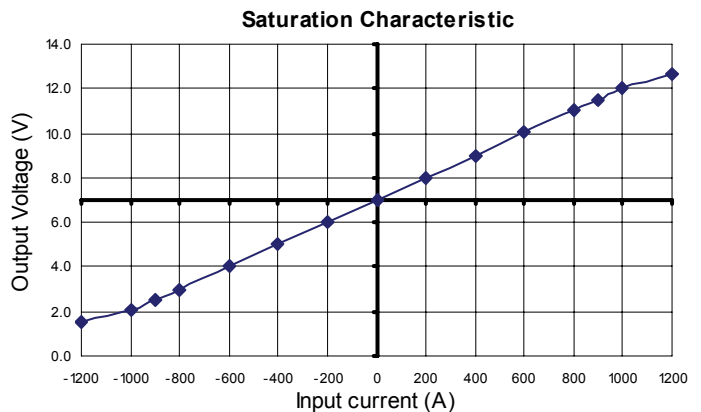
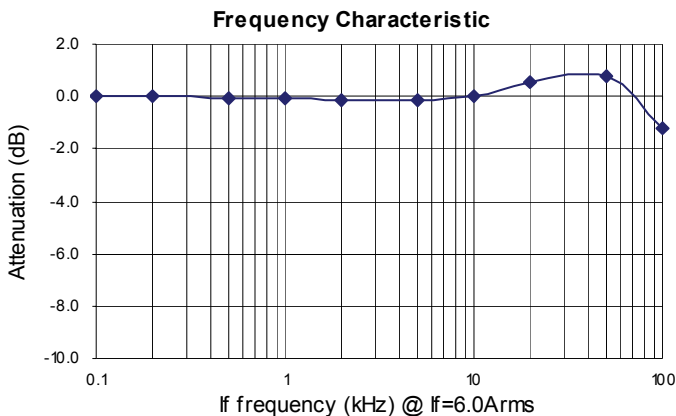

# Hall Effect Current Sensors L05Z\*\*\*S15 Series

## Mechanical dimensions in mm

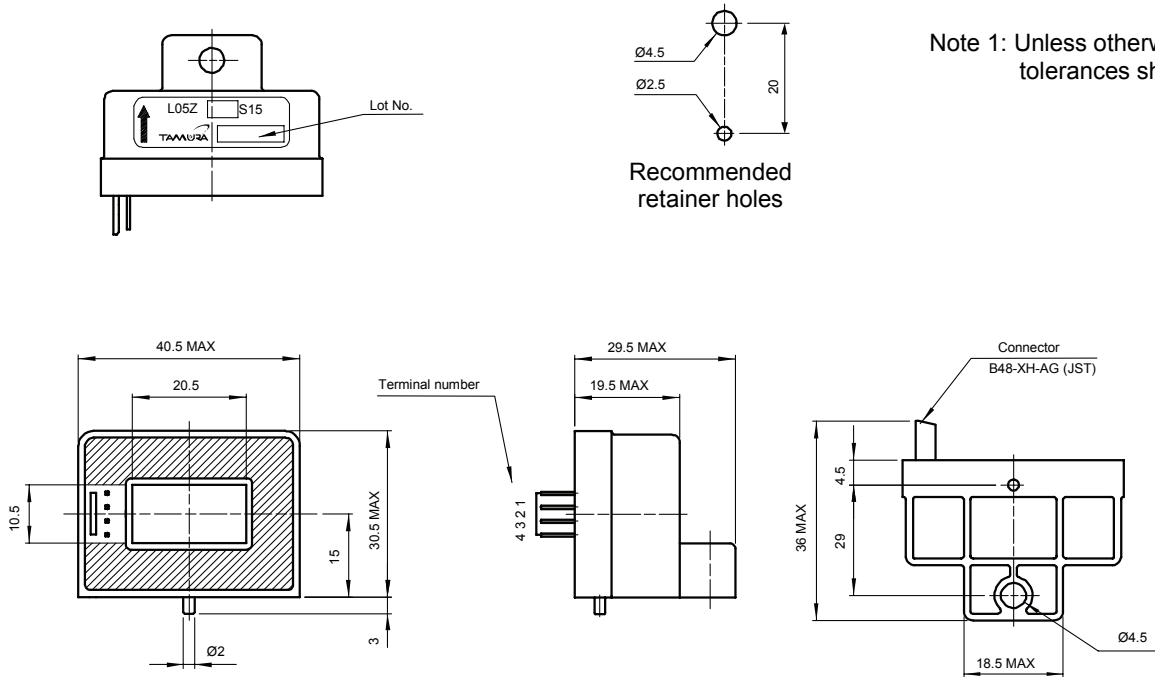

## Electrical connection diagram

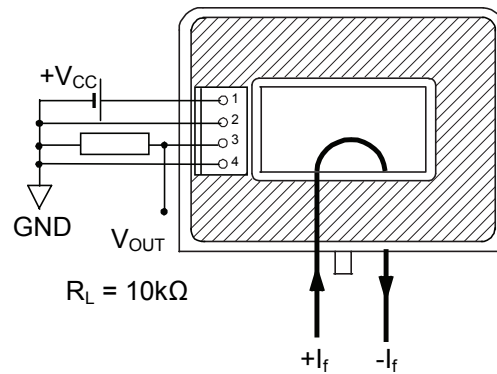

## Package & Weight Information

Weight	Pcs/box	Pcs/carton	Pcs/pallet
51g	20	200	9600