

Specifications:

connector description (1)	dc plug, 5.5x2.5xL22.5 mm, molding style, brass nickel plated, P/N 50-00130
overmold (2)	30P, PVC, black
wire description (3)	2C, 24 AWG, UL2468, 300V, 80C, 3.6 mm, VW-1, PVC, 65P, P/N 30-00003
cable outer diameter	Ø3.6 mm
cable color	black
cable length	1830 ± 50 mm
twist tie (4)	black, 89 ± 3 mm
rated current	500 mA, 36 Vdc

Notes:

Function test: no open, no reversed polarity, no short circuit, no INT
 RoHS compliant

Mechanical drawing:

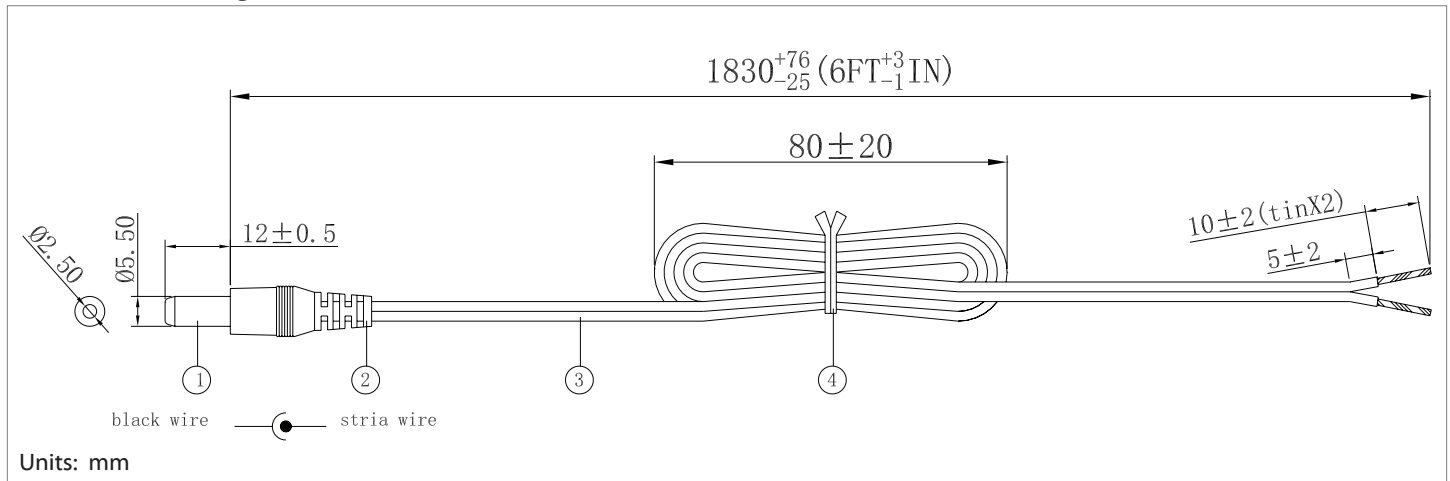

tolerance X: ±0.5 mm .X: ±0.3 mm .XX: ±0.05 mm
 applicable unless otherwise indicated in specification or on drawings
 Tensility International Corporation reserves the right to substitute
 parts which are functionally equivalent to the ones specified.

Initial

Date

Revision notes:

Rev	Date	Description
A	January 19, 2009	Re-issued; original specification issued by CUI, re-issued by Tensility without any material or mechanical changes.
A1	January 15, 2009	updated tolerances
A2	August 30, 2011	updated description, connector, and wire information

Specification Approval

Spec sign-off verifies that you have reviewed the entire specification, tested a sample of the product, and confirm that it meets your requirements. This specification reflects the part as it will be ordered. Orders will not be processed until the specification pages have been initialed and the approval page has been signed. This specification is confidential and is not to be transmitted without prior approval from Tensility.

Signature _____ Title _____
 Name _____ Date _____
 Company _____ Branch _____