

# DATA SHEET

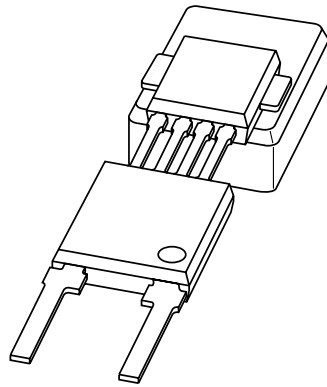

## **KMI15/4** Rotational speed sensor

Product specification  
Supersedes data of 2000 Jun 26

2000 Sep 05

# Rotational speed sensor

KMI15/4

## FEATURES

- Digital current output signal
- Zero speed capability
- Wide air gap
- Wide temperature range
- Vibration insensitive
- EMC resistant.

## DESCRIPTION

The KMI15/4 sensor detects rotational speed of ferrous gear wheels and reference marks<sup>(1)</sup>. The sensor consists of a magnetoresistive sensor element, a signal conditioning integrated circuit in bipolar technology and a ferrite magnet. The frequency of the digital current output signal is proportional to the rotational speed of a gear wheel.

<b>CAUTION</b>
Do not press two or more products together against their magnetic forces.

(1) The sensor contains a customized integrated circuit. Usage in hydraulic brake systems and in systems with active brake control is forbidden. For all other applications, higher temperature versions of up to 150 °C are available on request.

## PINNING

PIN	DESCRIPTION
1	V <sub>CC</sub>
2	V-

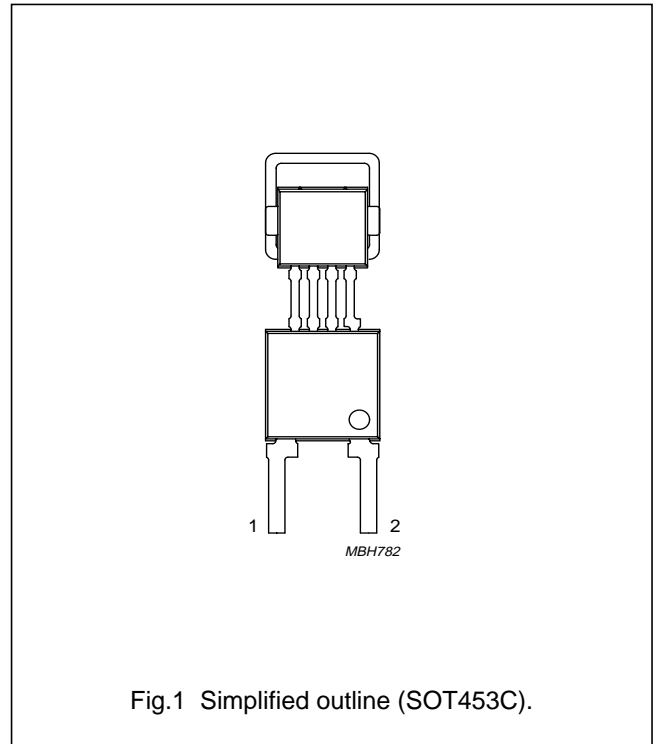

Fig.1 Simplified outline (SOT453C).

## QUICK REFERENCE DATA

SYMBOL	PARAMETER	MIN.	TYP.	MAX.	UNIT
V <sub>CC</sub>	DC supply voltage	-	12	-	V
T <sub>amb</sub>	ambient operating temperature	-40	-	+85	°C
I <sub>CC (low)</sub>	current output signal low	-	7	-	mA
I <sub>CC (high)</sub>	current output signal high	-	14	-	mA
f <sub>t</sub>	operating tooth frequency	0	-	25000	Hz
d	sensing distance	0 to 2.0	0 to 2.3	-	mm

## Rotational speed sensor

KMI15/4

**LIMITING VALUES**

In accordance with Absolute Maximum Rating System (IEC 60134).

SYMBOL	PARAMETER	CONDITIONS	MIN.	MAX.	UNIT
$V_{CC}$	DC supply voltage	$T_{amb} = -40$ to $+85$ °C; $R_L = 115$ $\Omega$	-0.5	+16	V
$T_{stg}$	storage temperature		-40	+150	°C
$T_{amb}$	operating ambient temperature		-40	+85	°C
$T_{sld}$	soldering temperature	$t \leq 10$ s	-	260	°C
	output short-circuit duration to GND		continuous		

**CHARACTERISTICS**

$T_{amb} = 25$  °C;  $V_{CC} = 12$  V;  $d = 1.5$  mm;  $f_t = 2$  kHz; test circuit: see Fig.7;  $R_L = 115$   $\Omega$ ; sensor positioning: see Fig.15; gear wheel: module 2 mm; material 1.0715; unless otherwise specified.

SYMBOL	PARAMETER	CONDITIONS	MIN.	TYP.	MAX.	UNIT
$I_{CC (low)}$	current output signal low	see Figs 6 and 8	5.6	7	8.4	mA
$I_{CC (high)}$	current output signal high	see Figs 6 and 8	11.2	14	16.8	mA
$t_r$	output signal rise time	$C_L = 100$ pF; see Fig.9; 10 to 90% value	-	0.5	-	$\mu$ s
$t_f$	output signal fall time	$C_L = 100$ pF; see Fig.9; 10 to 90% value	-	0.7	-	$\mu$ s
$t_d$	switching delay time	between stimulation pulse (generated by a coil) and output signal	-	1	-	$\mu$ s
$f_t$	operating tooth frequency	for both rotation directions	0	-	25000	Hz
$d$	sensing distance	see Fig.15 and note 1	0 to 2.0	0 to 2.3	-	mm
$\delta$	duty cycle	see Fig.6	20	50	80	%

**Note**

1. High rotational speeds of wheels reduce the sensing distance due to eddy current effects (see Fig.17).

# Rotational speed sensor

# KMI15/4

### FUNCTIONAL DESCRIPTION

The KMI15/4 sensor is sensitive to the motion of ferrous gear wheels or reference marks. The functional principle is shown in Fig.3. Due to the effect of flux bending, the different directions of magnetic field lines in the magneto-resistive sensor element will cause an electrical signal. Because of the chosen sensor orientation and the direction of ferrite magnetization, the KMI15/4 is sensitive to movement in the 'y' direction in front of the sensor only (see Fig.2).

The magneto-resistive sensor element signal is amplified, temperature compensated and passed to a Schmitt-trigger in the conditioning integrated circuit (Figs 4 and 5). The digital output signal level (see Fig.6) is at a fixed level independent of the sensing distance. A (2-wire) output current enables safe sensor signal transport to the detecting circuit (see Fig.7). The integrated circuit housing is separated from the sensor element housing to optimize the sensor behaviour at high temperatures.

The strength of the magnetic field caused by the Ferroxdure 100 magnet in the different sensor directions, measured at the centre of the magneto-resistive bridge, is typically:  $H_x = 7 \text{ kA/m}$  (auxiliary field) and  $H_z = 17 \text{ kA/m}$  (perpendicular to the sensor surface).  $H_y$  is zero due to the trimming process.

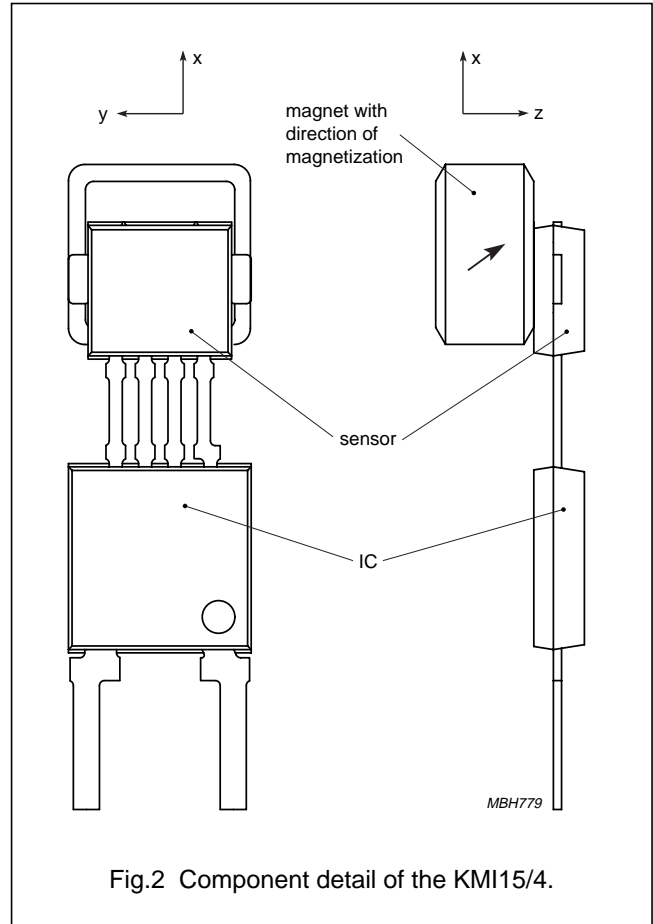

Fig.2 Component detail of the KMI15/4.

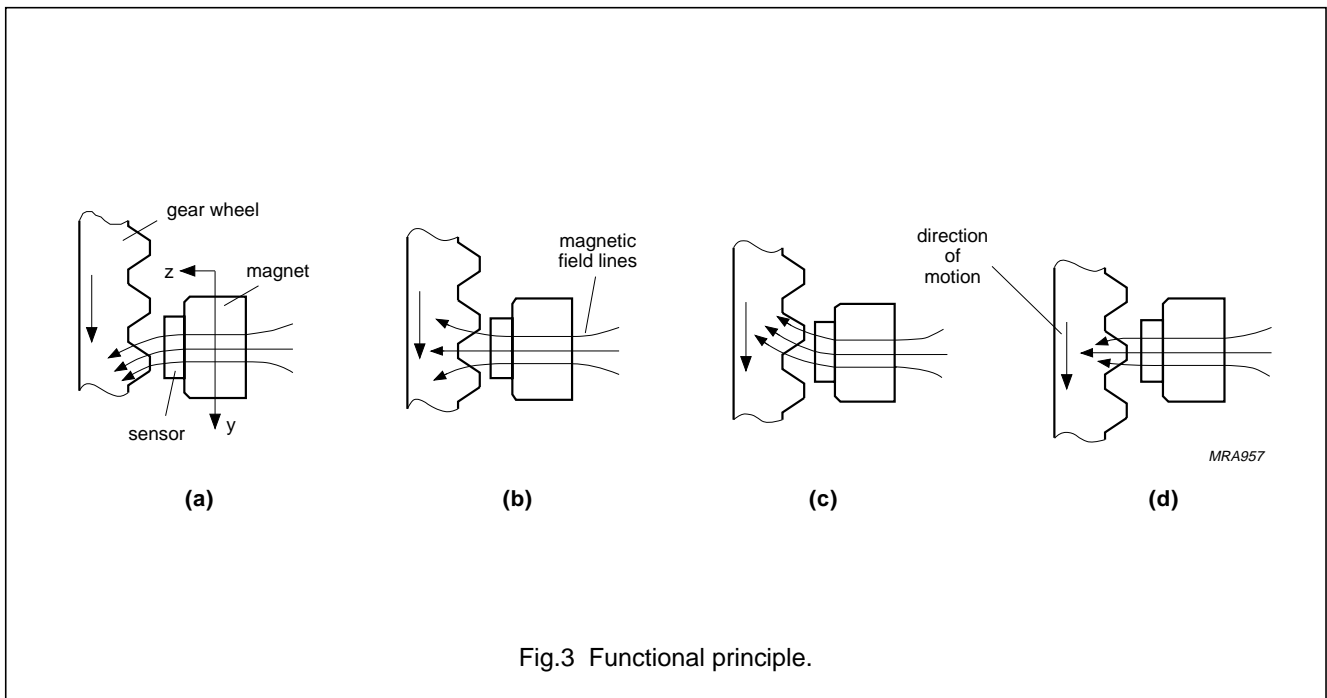

Fig.3 Functional principle.

Rotational speed sensor

KMI15/4

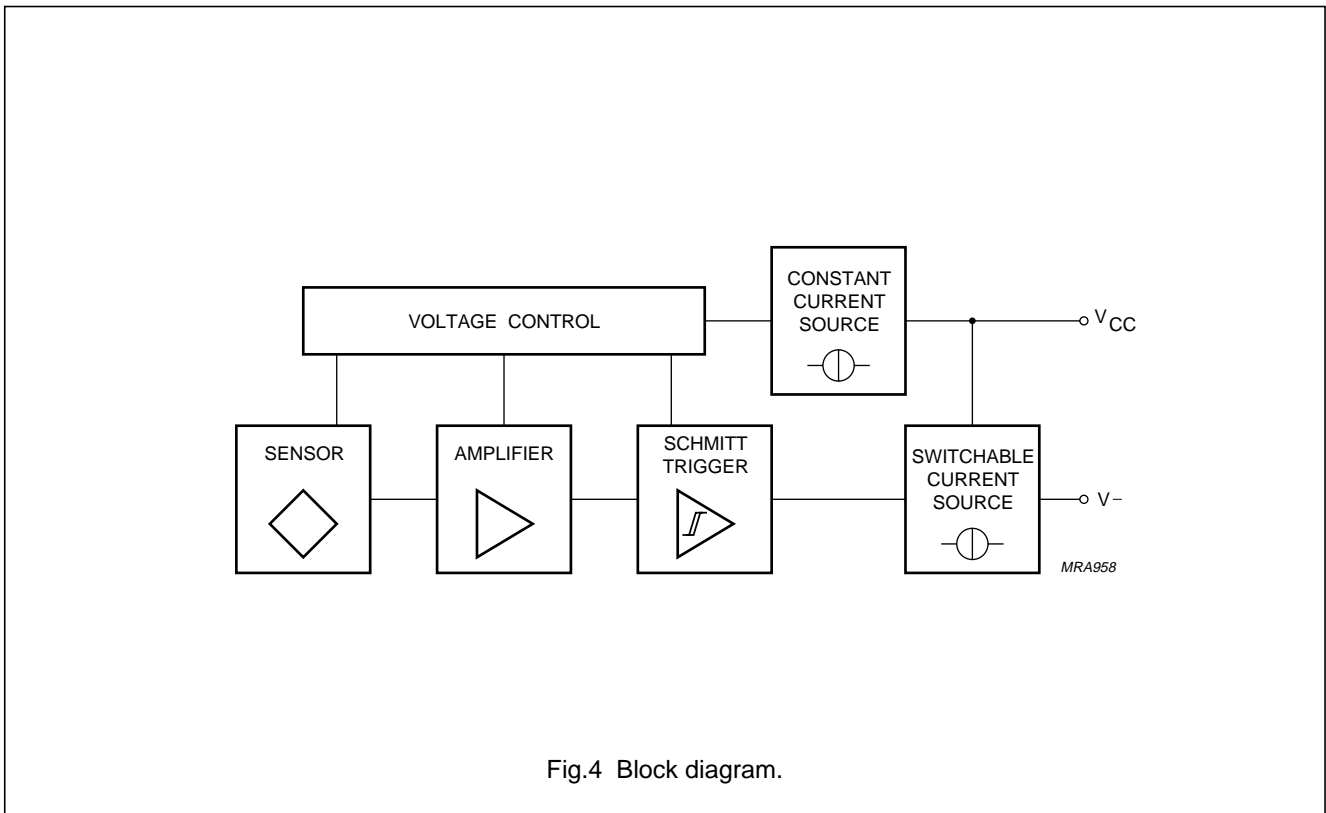

Fig.4 Block diagram.

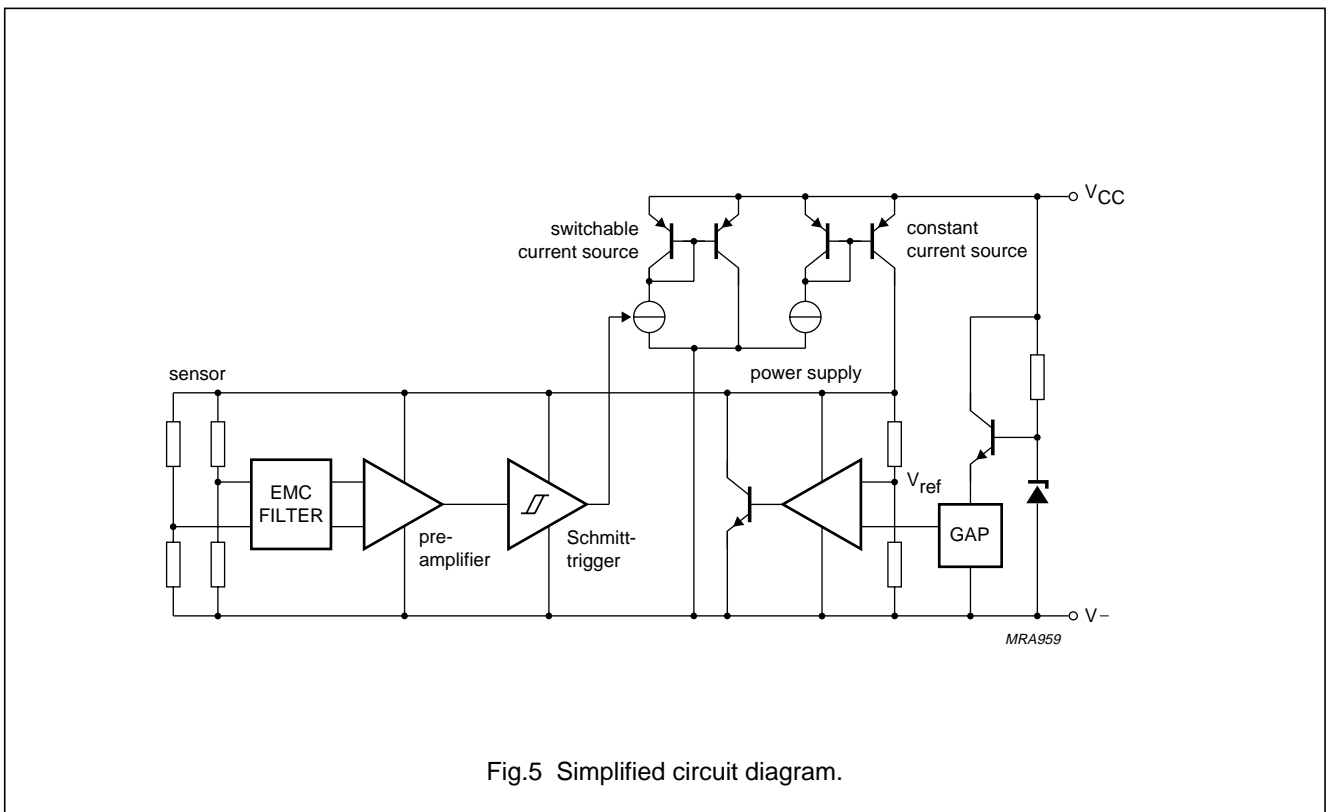
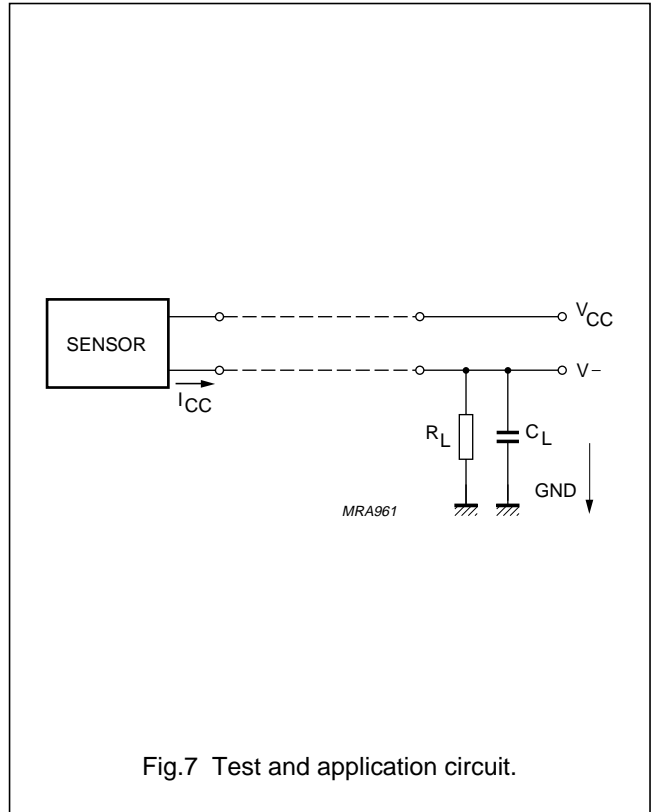
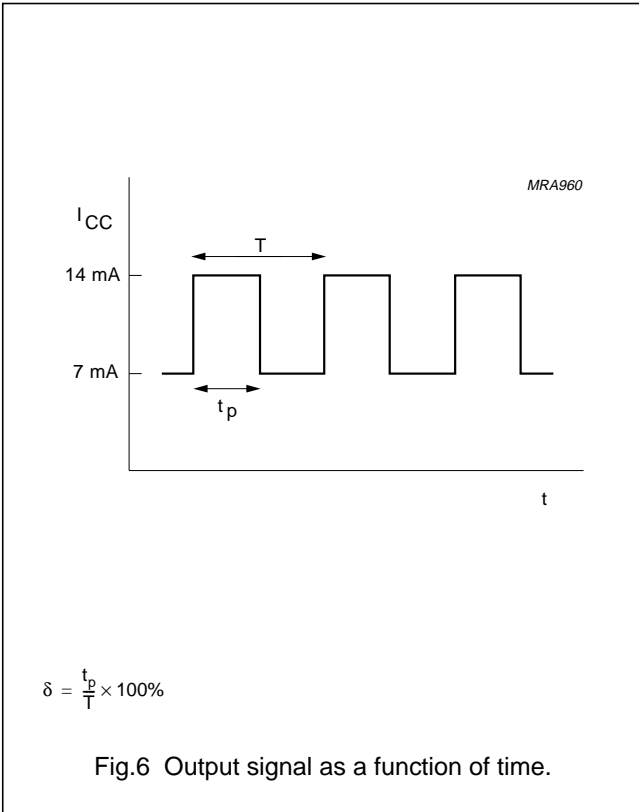

Fig.5 Simplified circuit diagram.

Rotational speed sensor

KMI15/4



APPLICATION INFORMATION

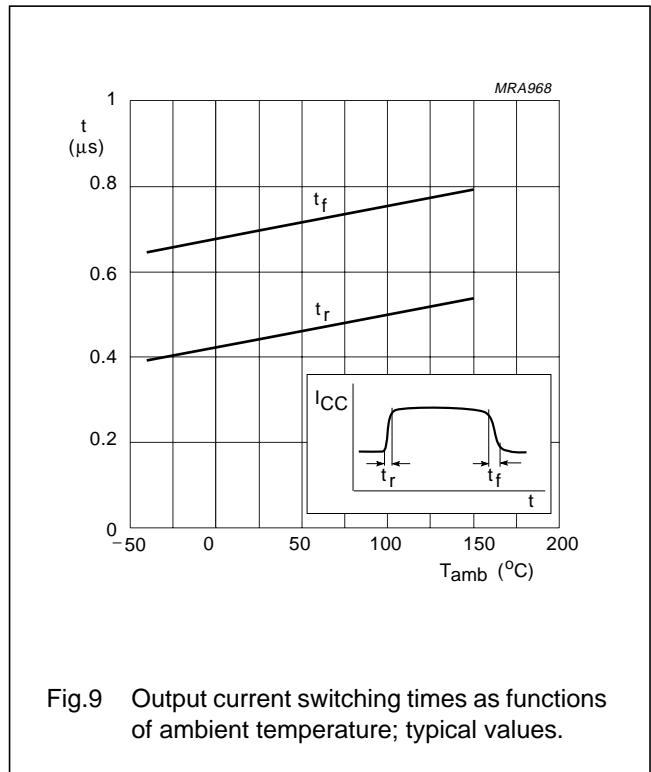
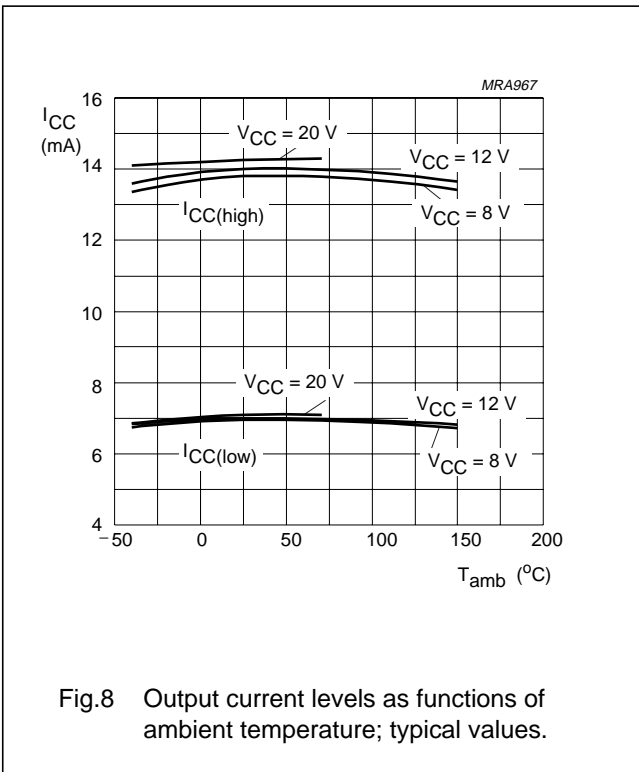

# Rotational speed sensor

KMI15/4

### Mounting conditions

The recommended sensor position in front of a gear wheel is shown in Fig.15. Distance 'd' is measured between the sensor front and the tip of a gear wheel tooth. The KMI15/4 senses ferrous indicators like gear wheels in the ± y direction only (no rotational symmetry of the sensor); see Fig.2. The effect of incorrect mounting positions on sensing distance is shown in Figs 11, 12 and 13. The symmetrical reference axis of the sensor corresponds to the axis of the ferrite magnet.

### Environmental conditions

Due to eddy current effects the sensing distance depends on the tooth frequency (see Fig.17). The influence of gear wheel module on the sensing distance is shown in Fig.16.

### Gear Wheel Dimensions

SYMBOL	DESCRIPTION	UNIT
<b>German DIN</b>		
z	number of teeth	
d	diameter	mm
m	module $m = d/z$	mm
p	pitch $p = \pi \times m$	mm
<b>ASA; note1</b>		
PD	pitch diameter (d in inch)	inch
DP	diametric pitch $DP = z/PD$	inch <sup>-1</sup>
CP	circular pitch $CP = \pi/DP$	inch

### Note

- For conversion from ASA to DIN:  $m = 25.4 \text{ mm}/DP$ ;  $p = 25.4 \text{ mm} \times CP$ .

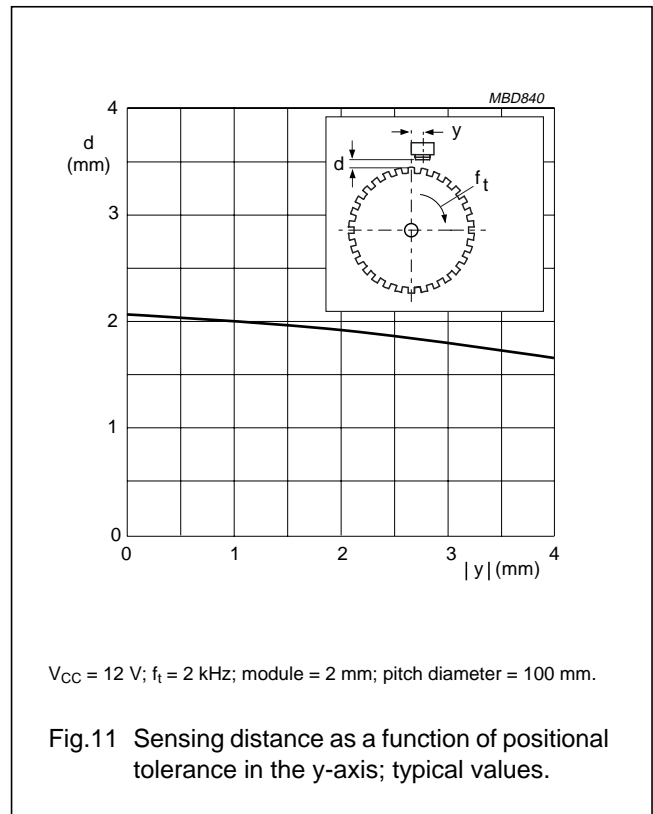
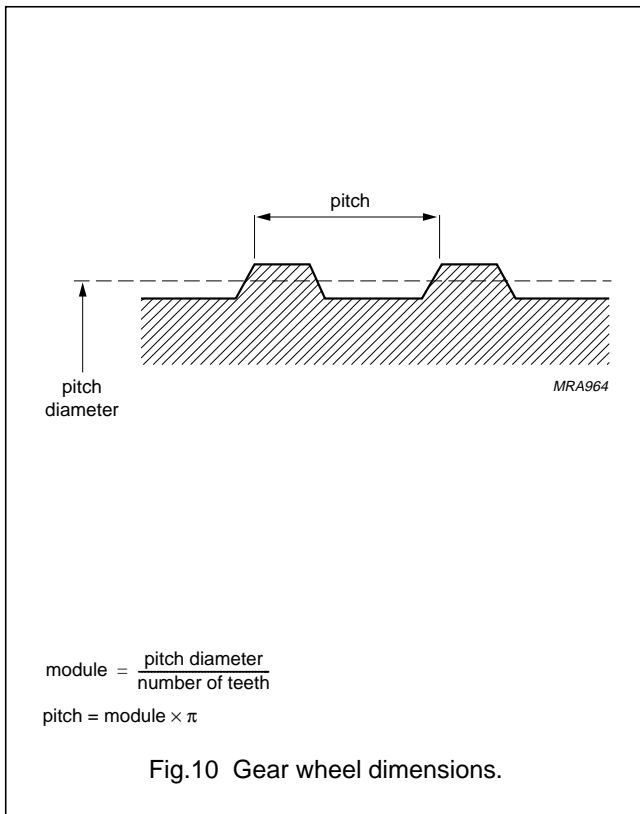

Rotational speed sensor

KMI15/4

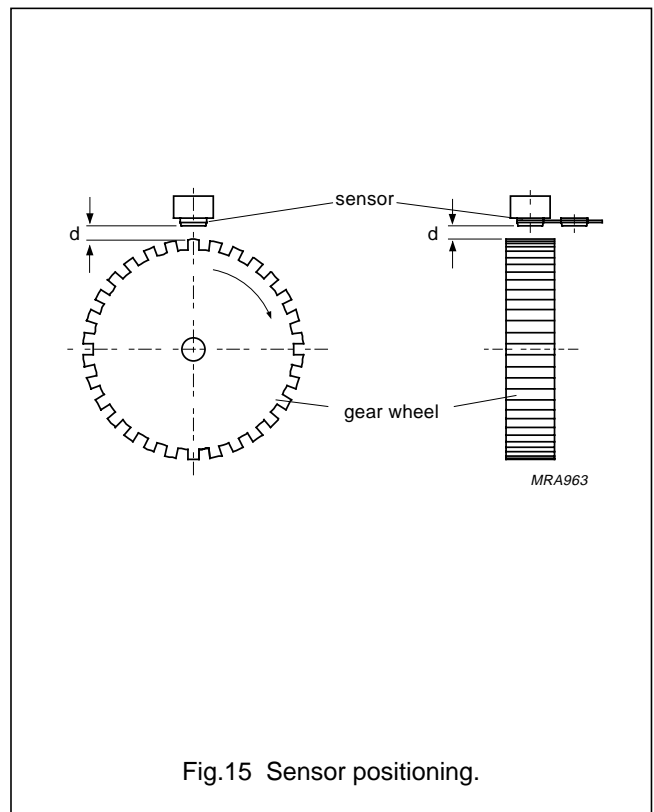
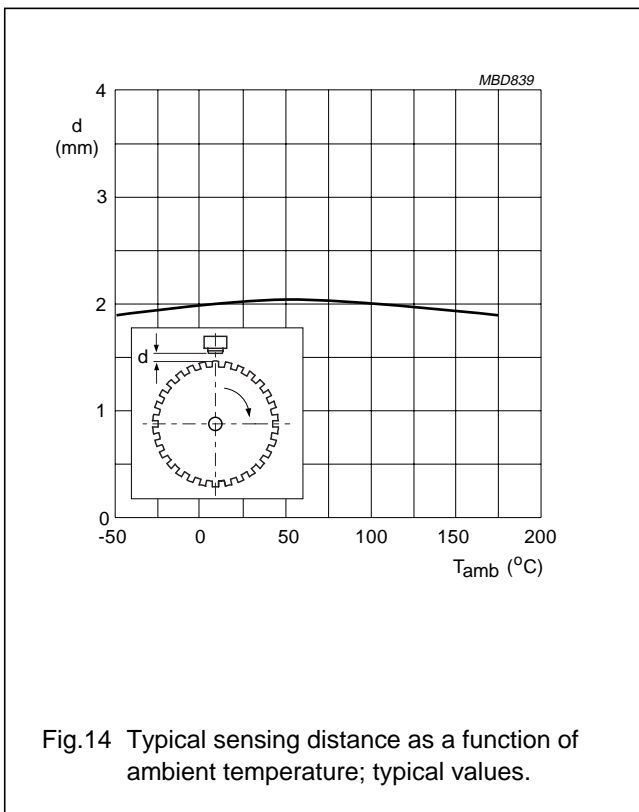
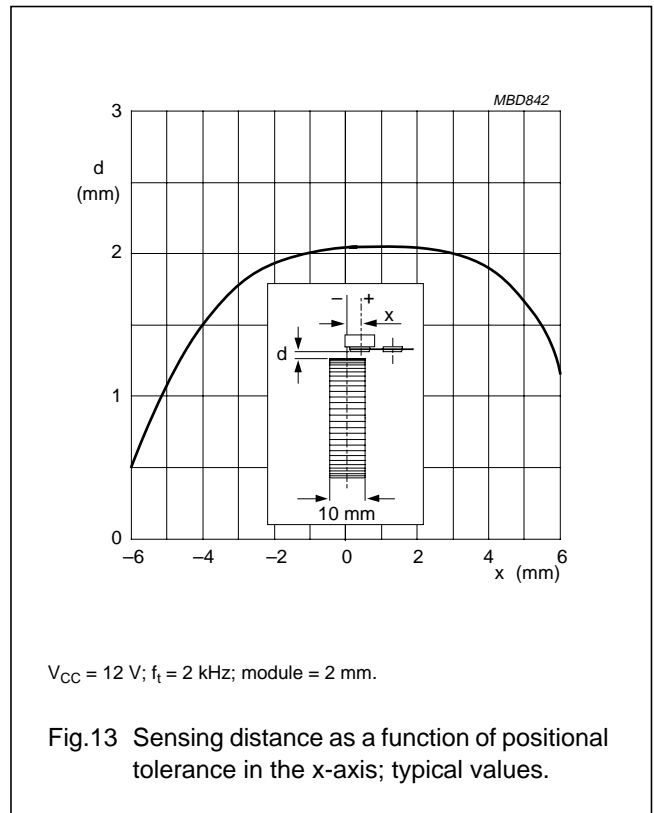
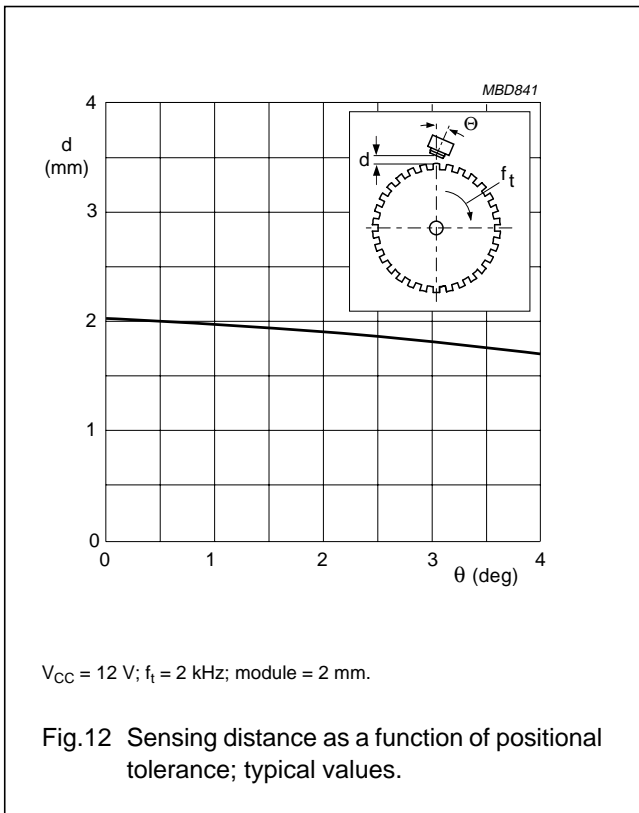



Rotational speed sensor

KMI15/4

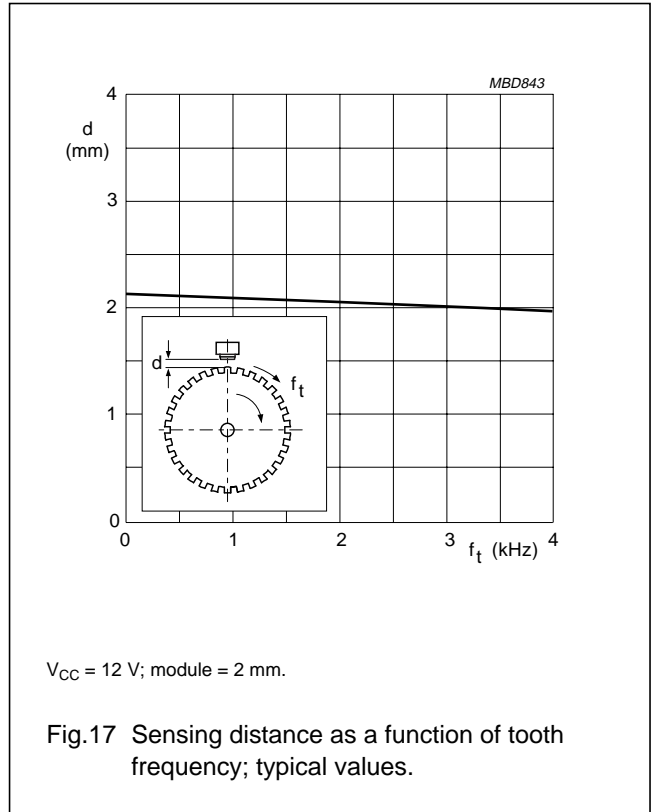
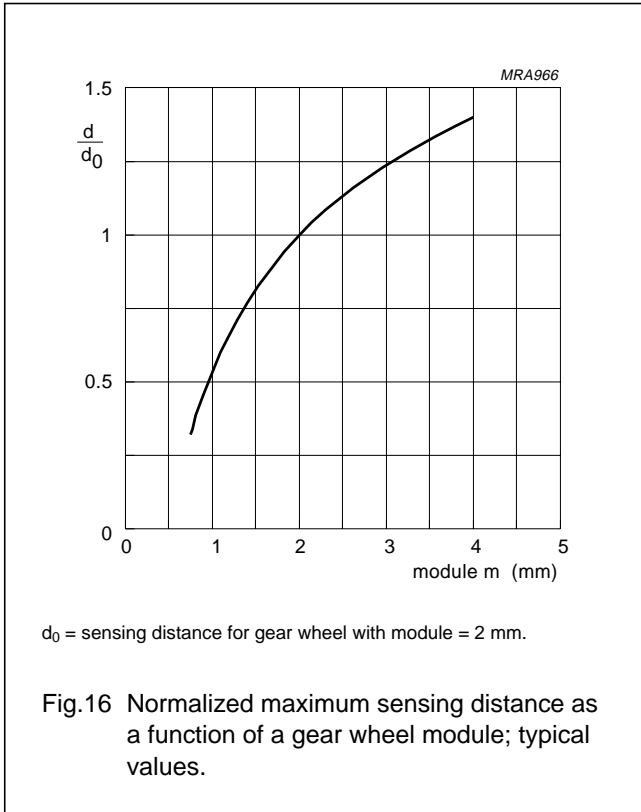

Rotational speed sensor

KMI15/4

**EMC**

Figure 18 shows a recommended application circuit for automotive applications (wheel sensing  $f_t < 5$  kHz). It provides a protection interface to meet Electromagnetic Compatibility (EMC) standards and safeguard against voltage spikes Table 1 lists the tests which are applicable to this circuit and the achieved class of functional status. Protection against 'load dump' (test pulse 5 according to "DIN 40839") means a very high demand on the protection circuit and requires a suitable suppressor diode with sufficient energy absorption capability.

The board net often contains a central load dump protection that makes such a device in the protection circuit of the sensor module unnecessary.

Tests for electrostatic discharge (ESD) were conducted in line with "IEC 801-2" to demonstrate the KMI15/4's handling capabilities. The "IEC 801-2" test conditions were:  $C = 150$  pF,  $R = 150 \Omega$ ,  $V = 2$  kV.

Electromagnetic disturbances with fields up to 150 V/m and  $f = 1$  GHz (ref. "DIN 40839") have no influence on performance.

**Table 1** EMC test results

EMC REF. DIN 40839	SYMBOL	MIN. (V)	MAX. (V)	REMARKS	CLASS
Test pulse 1	$V_{LD}$	-100	-	$t_d = 2$ ms	C
Test pulse 2	$V_{LD}$	-	100	$t_d = 0.2$ ms	A
Test pulse 3a	$V_{LD}$	-150	-	$t_d = 0.1 \mu s$	A
Test pulse 3b	$V_{LD}$	-	100	$t_d = 0.1 \mu s$	A
Test pulse 4	$V_{LD}$	-7	-	$t_d = 130$ ms	B
Test pulse 5	$V_{LD}$	-	120	$t_d = 400$ ms	B

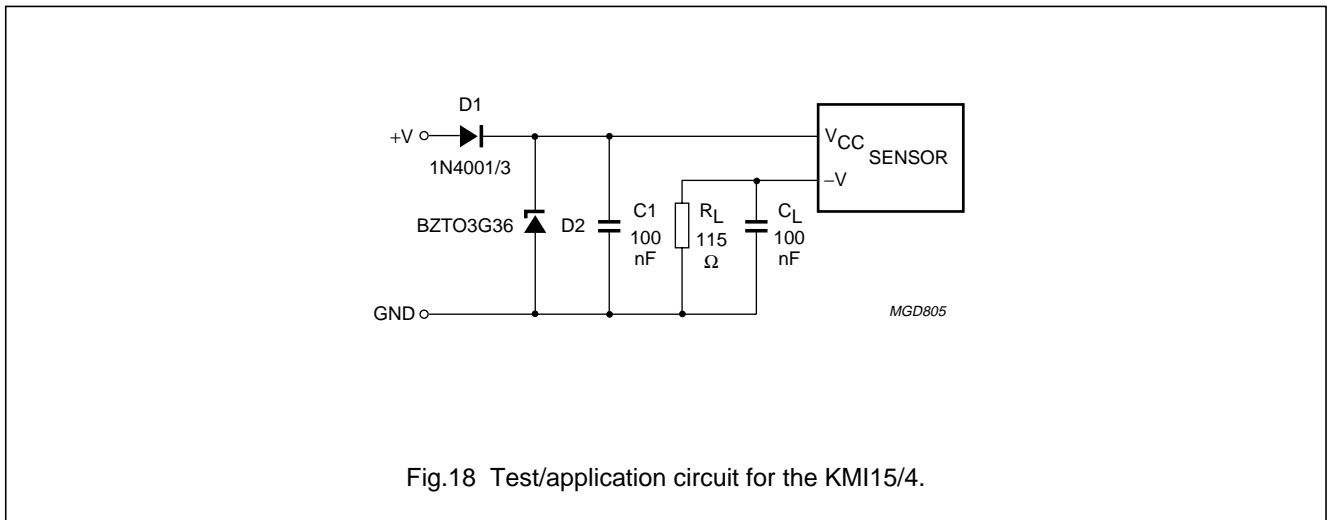

Fig.18 Test/application circuit for the KMI15/4.

# Rotational speed sensor

KMI15/4

## PACKAGE OUTLINE

Plastic single-ended multi-chip package;  
magnetized ferrite magnet (5.5 x 5.5 x 3 mm); 4 interconnections; 2 in-line leads

SOT453C

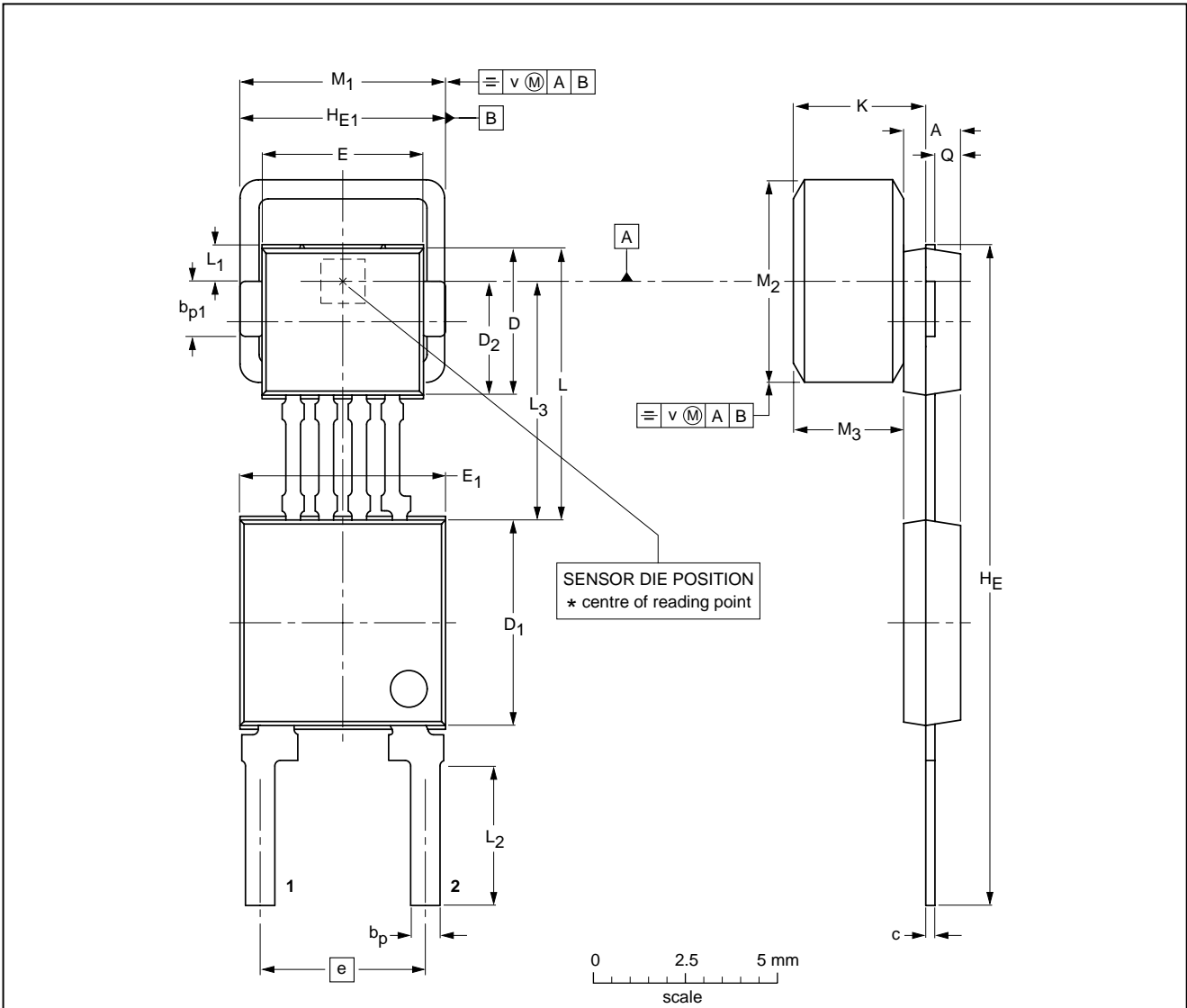

**DIMENSIONS (mm are the original dimensions)**

UNIT	A <sup>(1)</sup>	b <sub>p</sub>	b <sub>p1</sub>	c	D <sup>(2)</sup>	D <sub>1</sub> <sup>(2)</sup>	D <sub>2</sub> <sup>(2)</sup>	E <sup>(2)</sup>	E <sub>1</sub> <sup>(2)</sup>	e	H <sub>E</sub>	H <sub>E1</sub>	K <sub>max.</sub>	L	L <sub>1</sub>	L <sub>2</sub>	L <sub>3</sub>	M <sub>1</sub>	M <sub>2</sub>	M <sub>3</sub> <sup>(1)</sup>	Q	v
mm	1.7 1.4	0.8 0.7	1.57 1.47	0.3 0.24	4.1 3.9	5.7 5.5	3.15 2.95	4.5 4.3	5.7 5.5	4.6 4.4	18.2 17.8	5.6 5.5	3.87	7.55 7.25	1.2 0.9	3.9 3.5	6.55 6.35	5.65 5.35	5.65 5.35	3.15 2.85	0.75 0.65	0.25

**Notes**

1. Glue thickness not included.
2. Plastic or metal protrusions of 0.15 mm maximum per side are not included.

OUTLINE VERSION	REFERENCES				EUROPEAN PROJECTION	ISSUE DATE
	IEC	JEDEC	EIAJ			
SOT453C						99-09-23- 00-08-31

## Rotational speed sensor

KMI15/4

## DATA SHEET STATUS

DATA SHEET STATUS	PRODUCT STATUS	DEFINITIONS <sup>(1)</sup>
Objective specification	Development	This data sheet contains the design target or goal specifications for product development. Specification may change in any manner without notice.
Preliminary specification	Qualification	This data sheet contains preliminary data, and supplementary data will be published at a later date. Philips Semiconductors reserves the right to make changes at any time without notice in order to improve design and supply the best possible product.
Product specification	Production	This data sheet contains final specifications. Philips Semiconductors reserves the right to make changes at any time without notice in order to improve design and supply the best possible product.

## Note

1. Please consult the most recently issued data sheet before initiating or completing a design.

## DEFINITIONS

**Short-form specification** — The data in a short-form specification is extracted from a full data sheet with the same type number and title. For detailed information see the relevant data sheet or data handbook.

**Limiting values definition** — Limiting values given are in accordance with the Absolute Maximum Rating System (IEC 60134). Stress above one or more of the limiting values may cause permanent damage to the device. These are stress ratings only and operation of the device at these or at any other conditions above those given in the Characteristics sections of the specification is not implied. Exposure to limiting values for extended periods may affect device reliability.

**Application information** — Applications that are described herein for any of these products are for illustrative purposes only. Philips Semiconductors make no representation or warranty that such applications will be suitable for the specified use without further testing or modification.

## DISCLAIMERS

**Life support applications** — These products are not designed for use in life support appliances, devices, or systems where malfunction of these products can reasonably be expected to result in personal injury. Philips Semiconductors customers using or selling these products for use in such applications do so at their own risk and agree to fully indemnify Philips Semiconductors for any damages resulting from such application.

**Right to make changes** — Philips Semiconductors reserves the right to make changes, without notice, in the products, including circuits, standard cells, and/or software, described or contained herein in order to improve design and/or performance. Philips Semiconductors assumes no responsibility or liability for the use of any of these products, conveys no licence or title under any patent, copyright, or mask work right to these products, and makes no representations or warranties that these products are free from patent, copyright, or mask work right infringement, unless otherwise specified.

Rotational speed sensor

KMI15/4

---

**NOTES**

Rotational speed sensor

KMI15/4

---

**NOTES**

Rotational speed sensor

KMI15/4

---

**NOTES**

# Philips Semiconductors – a worldwide company

**Argentina:** see South America

**Australia:** 3 Figtree Drive, HOMEBUSH, NSW 2140,  
Tel. +61 2 9704 8141, Fax. +61 2 9704 8139

**Austria:** Computerstr. 6, A-1101 WIEN, P.O. Box 213,  
Tel. +43 1 60 101 1248, Fax. +43 1 60 101 1210

**Belarus:** Hotel Minsk Business Center, Bld. 3, r. 1211, Volodarski Str. 6,  
220050 MINSK, Tel. +375 172 20 0733, Fax. +375 172 20 0773

**Belgium:** see The Netherlands

**Brazil:** see South America

**Bulgaria:** Philips Bulgaria Ltd., Energoproject, 15th floor,  
51 James Bourchier Blvd., 1407 SOFIA,  
Tel. +359 2 68 9211, Fax. +359 2 68 9102

**Canada:** PHILIPS SEMICONDUCTORS/COMPONENTS,  
Tel. +1 800 234 7381, Fax. +1 800 943 0087

**China/Hong Kong:** 501 Hong Kong Industrial Technology Centre,  
72 Tat Chee Avenue, Kowloon Tong, HONG KONG,  
Tel. +852 2319 7888, Fax. +852 2319 7700

**Colombia:** see South America

**Czech Republic:** see Austria

**Denmark:** Sydhavnsgade 23, 1780 COPENHAGEN V,  
Tel. +45 33 29 3333, Fax. +45 33 29 3905

**Finland:** Sinikalliontie 3, FIN-02630 ESPOO,  
Tel. +358 9 615 800, Fax. +358 9 6158 0920

**France:** 51 Rue Carnot, BP317, 92156 SURESNES Cedex,  
Tel. +33 1 4099 6161, Fax. +33 1 4099 6427

**Germany:** Hammerbrookstraße 69, D-20097 HAMBURG,  
Tel. +49 40 2353 60, Fax. +49 40 2353 6300

**Hungary:** see Austria

**India:** Philips INDIA Ltd, Band Box Building, 2nd floor,  
254-D, Dr. Annie Besant Road, Worli, MUMBAI 400 025,  
Tel. +91 22 493 8541, Fax. +91 22 493 0966

**Indonesia:** PT Philips Development Corporation, Semiconductors Division,  
Gedung Philips, Jl. Buncit Raya Kav.99-100, JAKARTA 12510,  
Tel. +62 21 794 0040 ext. 2501, Fax. +62 21 794 0080

**Ireland:** Newstead, Clonskeagh, DUBLIN 14,  
Tel. +353 1 7640 000, Fax. +353 1 7640 200

**Israel:** RAPAC Electronics, 7 Kehilat Saloniki St, PO Box 18053,  
TEL AVIV 61180, Tel. +972 3 645 0444, Fax. +972 3 649 1007

**Italy:** PHILIPS SEMICONDUCTORS, Via Casati, 23 - 20052 MONZA (MI),  
Tel. +39 039 203 6838, Fax +39 039 203 6800

**Japan:** Philips Bldg 13-37, Kohnan 2-chome, Minato-ku,  
TOKYO 108-8507, Tel. +81 3 3740 5130, Fax. +81 3 3740 5057

**Korea:** Philips House, 260-199 Itaewon-dong, Yongsan-ku, SEOUL,  
Tel. +82 2 709 1412, Fax. +82 2 709 1415

**Malaysia:** No. 76 Jalan Universiti, 46200 PETALING JAYA, SELANGOR,  
Tel. +60 3 750 5214, Fax. +60 3 757 4880

**Mexico:** 5900 Gateway East, Suite 200, EL PASO, TEXAS 79905,  
Tel. +9-5 800 234 7381, Fax +9-5 800 943 0087

**Middle East:** see Italy

**Netherlands:** Postbus 90050, 5600 PB EINDHOVEN, Bldg. VB,  
Tel. +31 40 27 82785, Fax. +31 40 27 88399

**New Zealand:** 2 Wagener Place, C.P.O. Box 1041, AUCKLAND,  
Tel. +64 9 849 4160, Fax. +64 9 849 7811

**Norway:** Box 1, Manglerud 0612, OSLO,  
Tel. +47 22 74 8000, Fax. +47 22 74 8341

**Pakistan:** see Singapore

**Philippines:** Philips Semiconductors Philippines Inc.,  
106 Valero St. Salcedo Village, P.O. Box 2108 MCC, MAKATI,  
Metro MANILA, Tel. +63 2 816 6380, Fax. +63 2 817 3474

**Poland:** Al.Jerozolimskie 195 B, 02-222 WARSAW,  
Tel. +48 22 5710 000, Fax. +48 22 5710 001

**Portugal:** see Spain

**Romania:** see Italy

**Russia:** Philips Russia, Ul. Usatcheva 35A, 119048 MOSCOW,  
Tel. +7 095 755 6918, Fax. +7 095 755 6919

**Singapore:** Lorong 1, Toa Payoh, SINGAPORE 319762,  
Tel. +65 350 2538, Fax. +65 251 6500

**Slovakia:** see Austria

**Slovenia:** see Italy

**South Africa:** S.A. PHILIPS Pty Ltd., 195-215 Main Road Martindale,  
2092 JOHANNESBURG, P.O. Box 58088 Newville 2114,  
Tel. +27 11 471 5401, Fax. +27 11 471 5398

**South America:** Al. Vicente Pinzon, 173, 6th floor,  
04547-130 SÃO PAULO, SP, Brazil,  
Tel. +55 11 821 2333, Fax. +55 11 821 2382

**Spain:** Balmes 22, 08007 BARCELONA,  
Tel. +34 93 301 6312, Fax. +34 93 301 4107

**Sweden:** Kottbygatan 7, Akalla, S-16485 STOCKHOLM,  
Tel. +46 8 5985 2000, Fax. +46 8 5985 2745

**Switzerland:** Allmendstrasse 140, CH-8027 ZÜRICH,  
Tel. +41 1 488 2741 Fax. +41 1 488 3263

**Taiwan:** Philips Semiconductors, 5F, No. 96, Chien Kuo N. Rd., Sec. 1,  
TAIPEI, Taiwan Tel. +886 2 2134 2451, Fax. +886 2 2134 2874

**Thailand:** PHILIPS ELECTRONICS (THAILAND) Ltd.,  
60/14 MOO 11, Bangna Trad Road KM. 3, Bagna, BANGKOK 10260,  
Tel. +66 2 361 7910, Fax. +66 2 398 3447

**Turkey:** Yukari Dudullu, Org. San. Blg., 2.Cad. Nr. 28 81260 Umraniye,  
ISTANBUL, Tel. +90 216 522 1500, Fax. +90 216 522 1813

**Ukraine:** PHILIPS UKRAINE, 4 Patrice Lumumba str., Building B, Floor 7,  
252042 KIEV, Tel. +380 44 264 2776, Fax. +380 44 268 0461

**United Kingdom:** Philips Semiconductors Ltd., 276 Bath Road, Hayes,  
MIDDLESEX UB3 5BX, Tel. +44 208 730 5000, Fax. +44 208 754 8421

**United States:** 811 East Arques Avenue, SUNNYVALE, CA 94088-3409,  
Tel. +1 800 234 7381, Fax. +1 800 943 0087

**Uruguay:** see South America

**Vietnam:** see Singapore

**Yugoslavia:** PHILIPS, Trg N. Pasica 5/v, 11000 BEOGRAD,  
Tel. +381 11 3341 299, Fax.+381 11 3342 553

**For all other countries apply to:** Philips Semiconductors,  
Marketing Communications, Building BE-p, P.O. Box 218, 5600 MD EINDHOVEN,  
The Netherlands, Fax. +31 40 27 24825

**Internet:** <http://www.semiconductors.philips.com>

© Philips Electronics N.V. 2000

SCA 70

All rights are reserved. Reproduction in whole or in part is prohibited without the prior written consent of the copyright owner.

The information presented in this document does not form part of any quotation or contract, is believed to be accurate and reliable and may be changed without notice. No liability will be accepted by the publisher for any consequence of its use. Publication thereof does not convey nor imply any license under patent- or other industrial or intellectual property rights.

Printed in The Netherlands

613520/04/pp16

Date of release: 2000 Sep 05

Document order number: 9397 750 07471

*Let's make things better.*

**Philips**  
Semiconductors



**PHILIPS**