

Specification

Description

The Z-Power series is designed for high current operation and high flux output applications.

It incorporates state of the art SMD design and low thermal resistant material.

The Z Power LED is ideal light sources for general illumination applications, custom designed solutions, automotive, large LCD backlights and high performance torches.

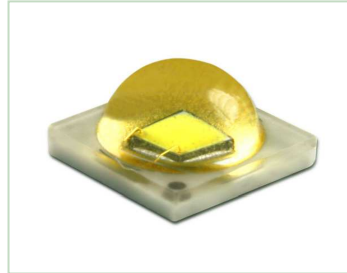

Z5

Features

- Super high Flux output and high Luminance
- Designed for high current operation
- SMT solderable
- Lead Free product
- RoHS compliant

Applications

- Mobile phone flash
- Automotive interior / exterior lighting
- Automotive signal lighting
- Automotive forward lighting
- General Torch
- Architectural lighting
- LCD TV / Monitor Backlight
- Projector light source
- Traffic signals
- Task lighting
- Decorative / Pathway lighting
- Remote / Solar powered lighting

* The appearance and specifications of the product can be changed for improvement without notice.

Rev. 10

August 2011

Outline dimensions

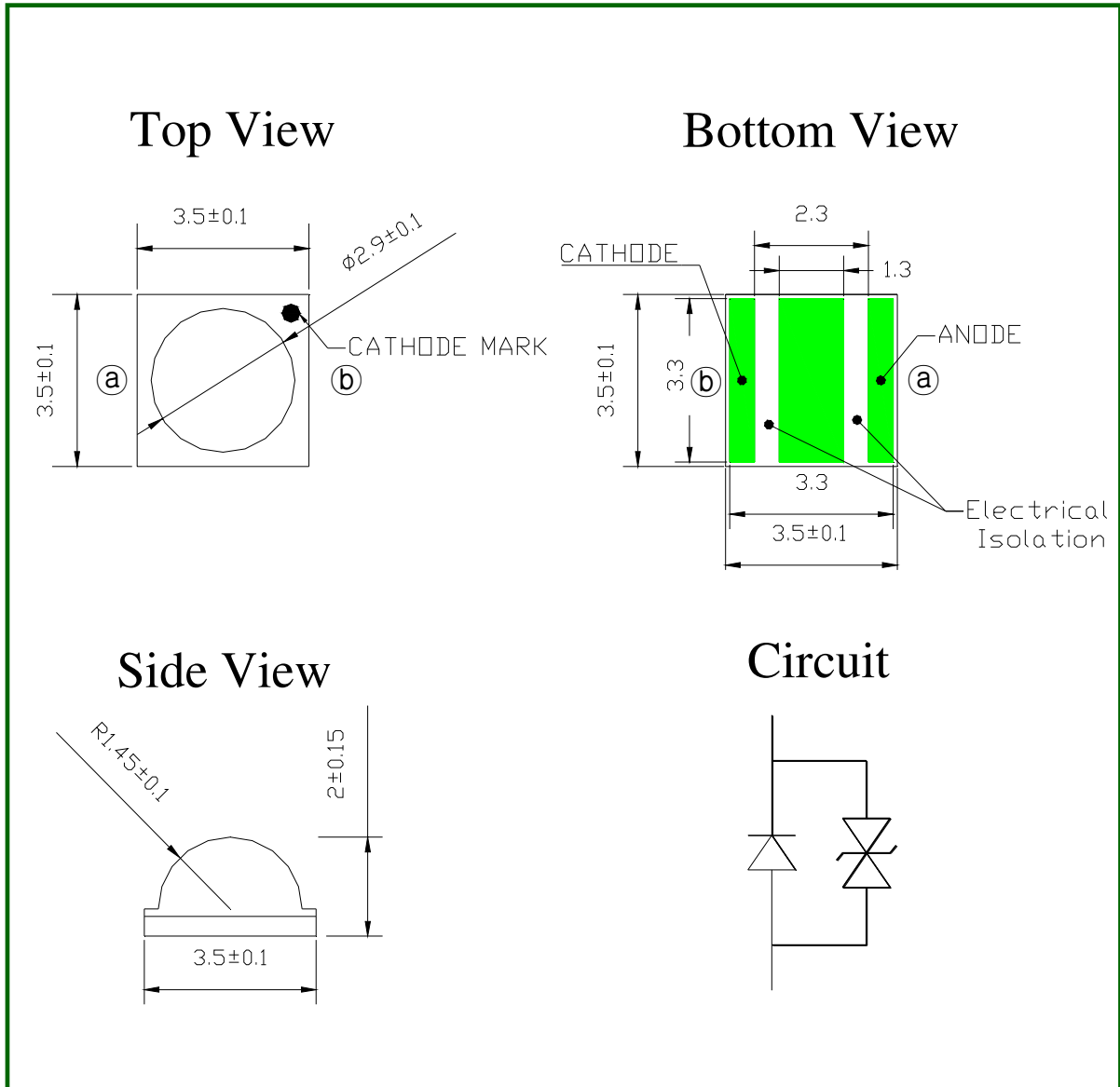

Notes :

- [1] All dimensions are in millimeters.
- [2] Scale : none
- [3] Undefined tolerance is ± 0.1mm

Characteristics of Z5 (Part no : SZW05A0A)

1. Pure white

1-1 Electro-Optical characteristics at 350mA

Parameter	Symbol	Value			Unit
		Min	Typ	Max	
Luminous Flux ^[1]	Φ_V ^[2]		105		lm
Correlated Color Temperature ^[3]	CCT	-	6300	-	K
CRI	R_a		70	-	-
Forward Voltage ^[4]	V_F		3.3	4	V
Thermal resistance (J to S)	$R_{\theta_{J-S}}$		9		K/W
View Angle	$2\theta_{1/2}$		120		deg.

1-2 Absolute Maximum Ratings

Parameter	Symbol	Value	Unit
Forward Current	I_F	700	mA
Reverse Voltage	V	5	V
Power Dissipation	P_d	2.8	W
Junction Temperature	T_j	145(@ $I_F \leq 700mA$)	°C
Operating Temperature	T_{opr}	-40 ~ +85	°C
Storage Temperature	T_{stg}	-40 ~ +100	°C
ESD Sensitivity ^[5]	-	± 8,000V HBM	-

*Notes :

- [1] SSC maintains a tolerance of ±10% on flux and power measurements.
- [2] Φ_V is the total luminous flux output as measured with an integrating sphere.
- [3] Correlated Color Temperature is derived from the CIE 1931 Chromaticity diagram.
Color coordinate : ± 0.005, CCT ±5% tolerance.
- [4] Tolerance is ±0.06V on forward voltage measurements
- [5] A zener diode is included to protect the product from ESD.

Temperature Characteristics Points

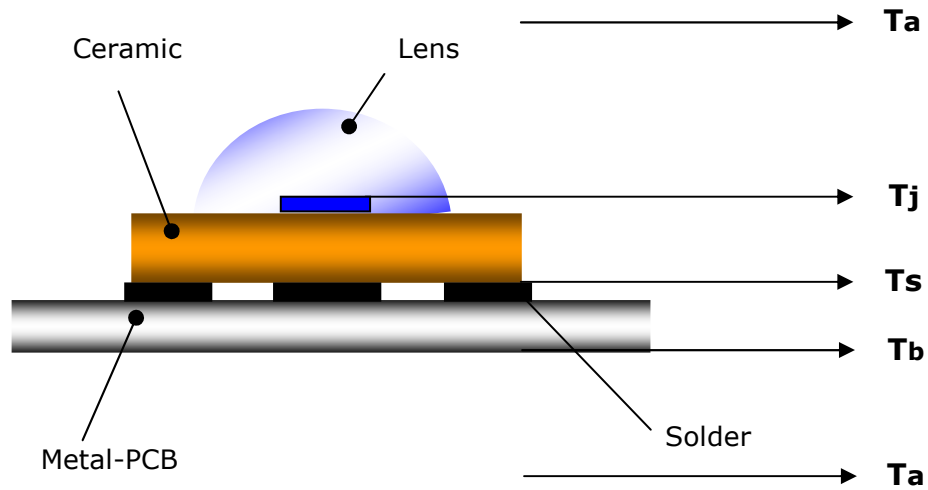

Color Spectrum $T_A=25^\circ\text{C}$

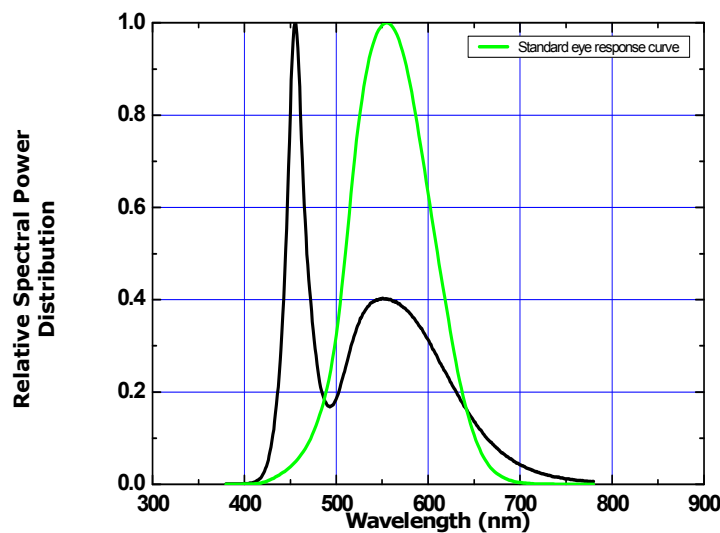

Forward Current Characteristics

Forward Voltage vs. Forward Current, Ta=25°C

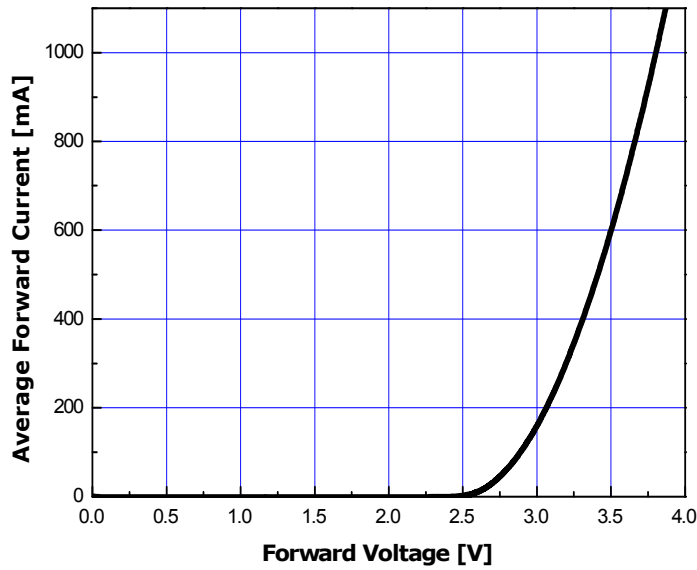

Forward Current vs. Normalized Relative Luminous Flux, Ta=25°C

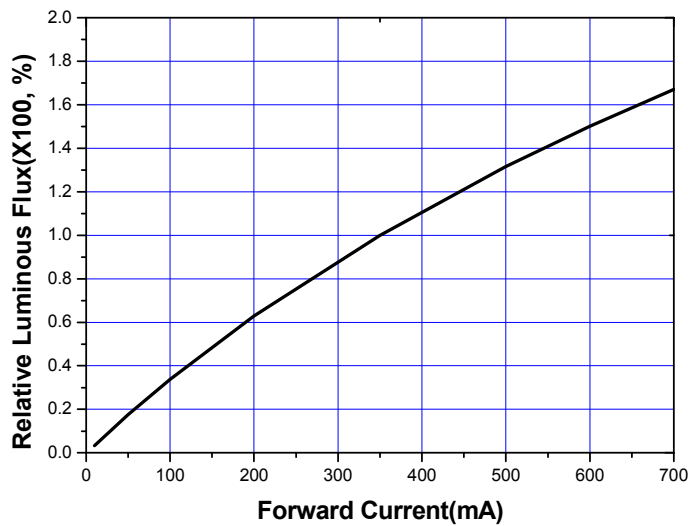

Junction Temperature Characteristics

Relative Light Output vs. Junction Temperature at $I_F=350\text{mA}$, $T_a=25^\circ\text{C}$

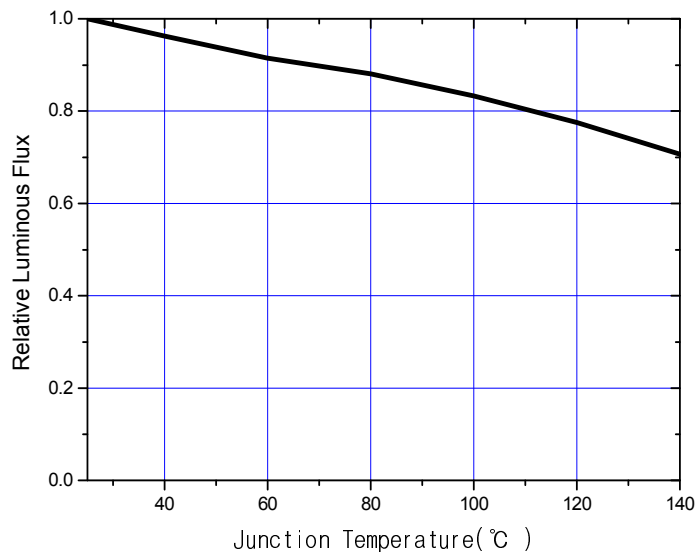

Forward Voltage Shift vs. Junction Temperature at $I_F=350\text{mA}$, $T_a=25^\circ\text{C}$

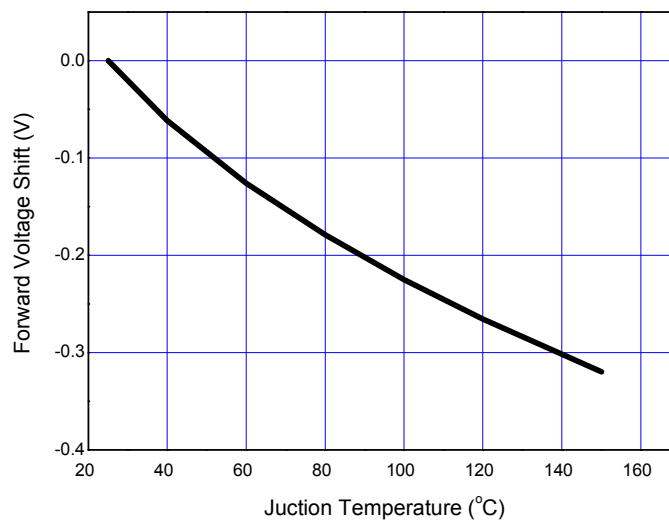

Radiation pattern

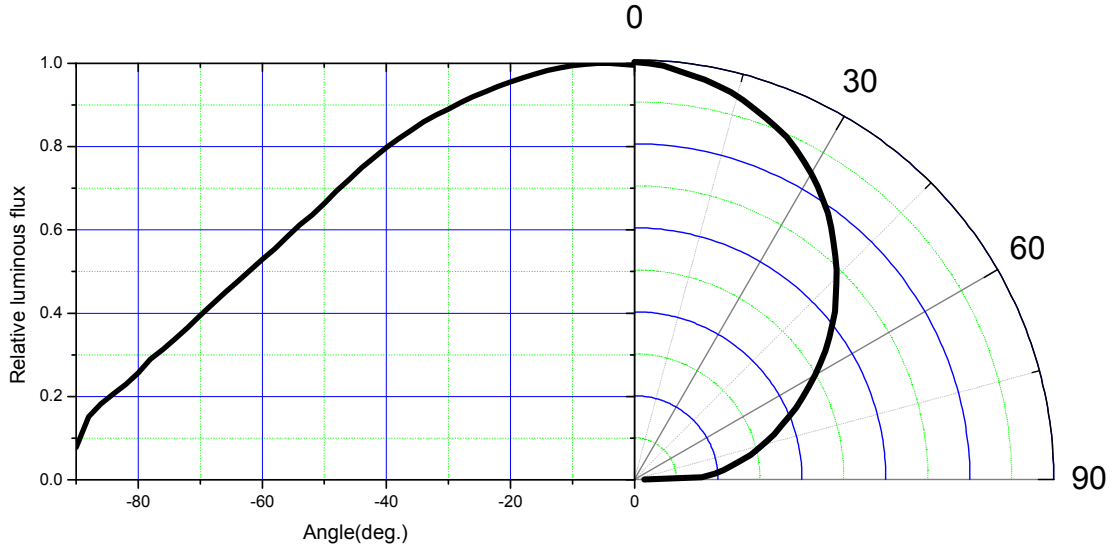

Maximum Forward Current vs. Ambient Temperature

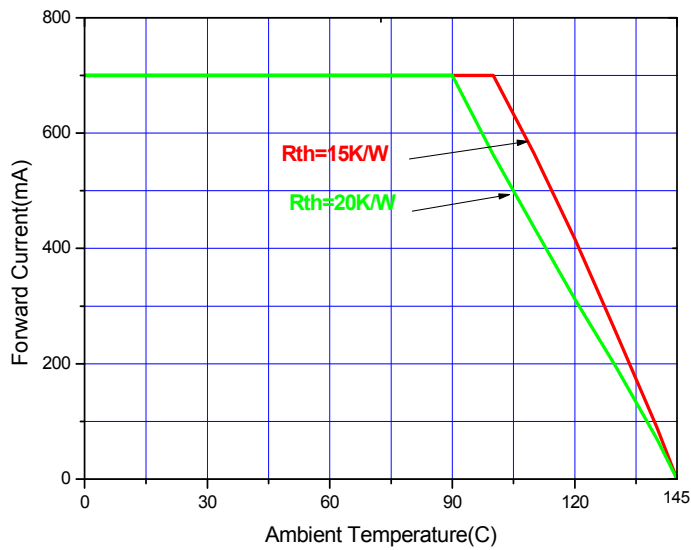

Binning Structure

IF=350mA, Ta=25°C

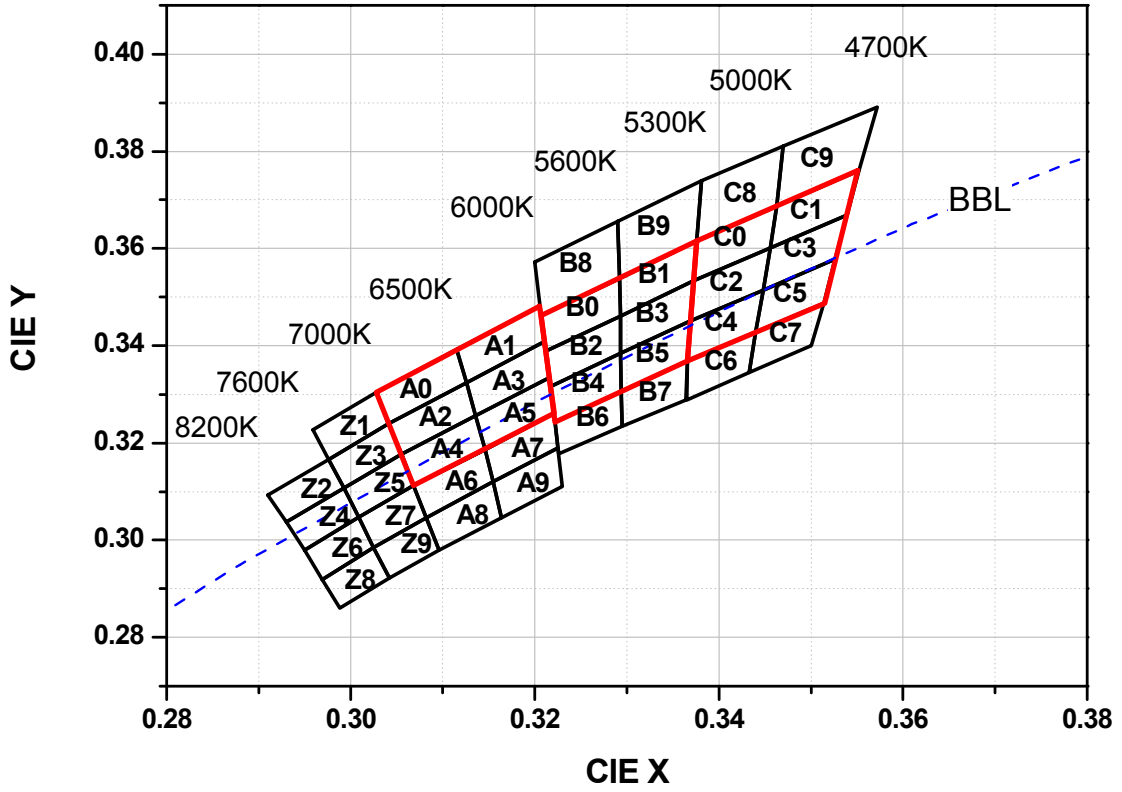

*** Note**
Red area is ANSI chromaticity.

Color & Binning

● COLOR RANK

<IF=350mA, Ta=25℃>

	CIE X	CIE Y		CIE X	CIE Y
Z8	0.2969	0.2919	Z9	0.3025	0.2985
	0.2988	0.2860		0.3042	0.2922
	0.3042	0.2922		0.3096	0.2980
	0.3025	0.2985		0.3082	0.3046
	0.2969	0.2919		0.3025	0.2985
Z6	0.2950	0.2980	Z7	0.3009	0.3047
	0.2969	0.2919		0.3025	0.2985
	0.3025	0.2985		0.3082	0.3046
	0.3009	0.3047		0.3068	0.3113
	0.2950	0.2980		0.3009	0.3047
Z4	0.2930	0.3037	Z5	0.2993	0.3107
	0.2950	0.2980		0.3009	0.3047
	0.3009	0.3047		0.3068	0.3113
	0.2993	0.3107		0.3055	0.3177
	0.2930	0.3037		0.2993	0.3107
Z2	0.2910	0.3093	Z3	0.2976	0.3166
	0.2930	0.3037		0.2993	0.3107
	0.2993	0.3107		0.3055	0.3177
	0.2976	0.3166		0.3041	0.3240
	0.2910	0.3093		0.2976	0.3166
			Z1	0.2959	0.3227
				0.2976	0.3166
				0.3041	0.3240
				0.3028	0.3304
				0.2959	0.3227

● COLOR RANK

<IF=350mA, Ta=25℃>

	CIE X	CIE Y		CIE X	CIE Y
A8	0.3082	0.3046	A9	0.3155	0.3120
	0.3096	0.2980		0.3164	0.3046
	0.3164	0.3046		0.3230	0.3110
	0.3155	0.3120		0.3225	0.3190
	0.3082	0.3046		0.3155	0.3120
A6	0.3068	0.3113	A7	0.3146	0.3187
	0.3082	0.3046		0.3155	0.3120
	0.3155	0.3120		0.3225	0.3190
	0.3146	0.3187		0.3221	0.3261
	0.3068	0.3113		0.3146	0.3187
A4	0.3055	0.3177	A5	0.3136	0.3256
	0.3068	0.3113		0.3146	0.3187
	0.3146	0.3187		0.3221	0.3261
	0.3136	0.3256		0.3216	0.3334
	0.3055	0.3177		0.3136	0.3256
A2	0.3041	0.3240	A3	0.3126	0.3324
	0.3055	0.3177		0.3136	0.3256
	0.3136	0.3256		0.3216	0.3334
	0.3126	0.3324		0.3210	0.3408
	0.3041	0.3240		0.3126	0.3324
A0	0.3028	0.3304	A1	0.3115	0.3393
	0.3041	0.3240		0.3126	0.3324
	0.3126	0.3324		0.3210	0.3408
	0.3115	0.3393		0.3205	0.3481
	0.3028	0.3304		0.3115	0.3393

● COLOR RANK

<IF=350mA, Ta=25℃>

	CIE X	CIE Y		CIE X	CIE Y
B6	0.3222	0.3243	B7	0.3294	0.3306
	0.3226	0.3178		0.3295	0.3234
	0.3295	0.3234		0.3364	0.3288
	0.3294	0.3306		0.3366	0.3369
	0.3222	0.3243		0.3294	0.3306
B4	0.3217	0.3316	B5	0.3293	0.3384
	0.3222	0.3243		0.3294	0.3306
	0.3294	0.3306		0.3366	0.3369
	0.3293	0.3384		0.3369	0.3451
	0.3217	0.3316		0.3293	0.3384
B2	0.3212	0.3389	B3	0.3293	0.3461
	0.3217	0.3316		0.3293	0.3384
	0.3293	0.3384		0.3369	0.3451
	0.3293	0.3461		0.3373	0.3534
	0.3212	0.3389		0.3293	0.3461
B0	0.3207	0.3462	B1	0.3292	0.3539
	0.3212	0.3389		0.3293	0.3461
	0.3293	0.3461		0.3373	0.3534
	0.3292	0.3539		0.3376	0.3616
	0.3207	0.3462		0.3292	0.3539
B8	0.3200	0.3572	B9	0.3290	0.3656
	0.3207	0.3462		0.3292	0.3539
	0.3292	0.3539		0.3376	0.3616
	0.3290	0.3656		0.3381	0.3740
	0.3200	0.3572		0.3290	0.3656

● COLOR RANK

<IF=350mA, Ta=25℃>

	CIE X	CIE Y		CIE X	CIE Y
C6	0.3366	0.3369	C7	0.3440	0.3428
	0.3364	0.3288		0.3433	0.3345
	0.3433	0.3345		0.3500	0.3400
	0.3440	0.3428		0.3514	0.3487
	0.3366	0.3369		0.3440	0.3428
C4	0.3369	0.3451	C5	0.3448	0.3514
	0.3366	0.3369		0.3440	0.3428
	0.3440	0.3428		0.3514	0.3487
	0.3448	0.3514		0.3526	0.3578
	0.3369	0.3451		0.3448	0.3514
C2	0.3373	0.3534	C3	0.3456	0.3601
	0.3369	0.3451		0.3448	0.3514
	0.3448	0.3514		0.3526	0.3578
	0.3456	0.3601		0.3539	0.3669
	0.3373	0.3534		0.3456	0.3601
C0	0.3376	0.3616	C1	0.3463	0.3687
	0.3373	0.3534		0.3456	0.3601
	0.3456	0.3601		0.3539	0.3669
	0.3463	0.3687		0.3552	0.3760
	0.3376	0.3616		0.3463	0.3687
C8	0.3381	0.3740	C9	0.3470	0.3810
	0.3470	0.3810		0.3572	0.3891
	0.3463	0.3687		0.3552	0.3760
	0.3376	0.3616		0.3463	0.3687
	0.3381	0.3740		0.3470	0.3810

Luminous Flux & Forward Voltage

Rank	LF [lm]	Condition
U1	91~100	350mA
U2	100~109	
U3	109~118.5	

Rank	V _F [V]	Condition
H	3.0~3.25	350mA
I	3.25~3.50	
J	3.50~3.75	
K	3.75~4.0	

Labeling

Rank : # 1# 2# 3# 4



QUANTITY : 1000



Lot No : # # # # # # # #



SSC PART NUMBER : SZW05A0A



SZW05A0A



Rank

1# 2# 3# 4

- #1 : Luminous Flux : LF [lm]
- #2#3 : Color Coordinates : x, y
- #4 : Forward Voltage : V_F [V]

Emitter Carrier & Reel Packaging

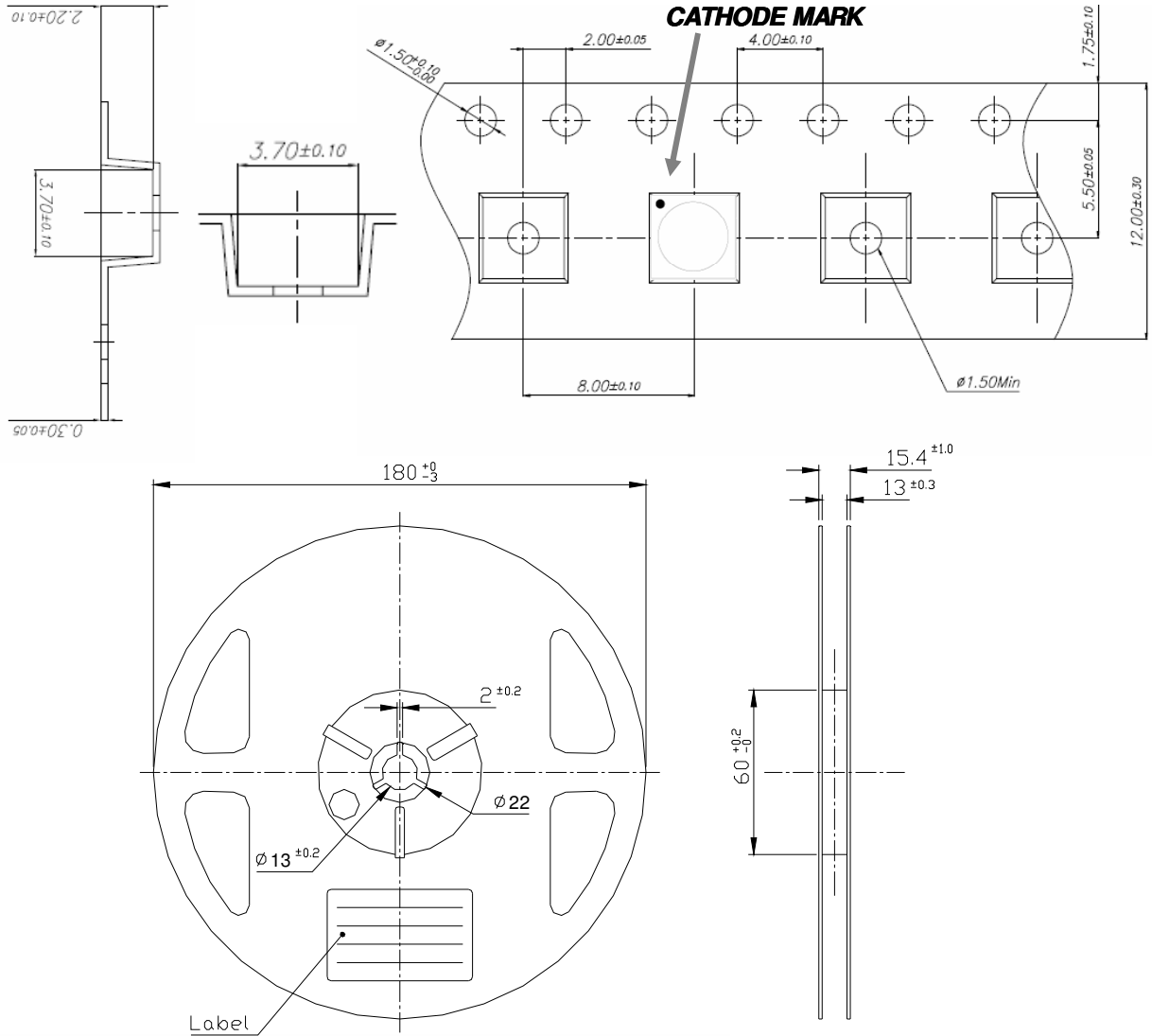

NOTES:

1. 10 sprocket hole pitch cumulative tolerance ± 0.20
2. Camber not to exceed 1mm in 250mm
3. Material: Black conductive Polystyrene
4. A_o and B_o measured on a plane 0.3mm above the bottom of the pocket
5. K_o measured from a plane on the inside bottom of the pocket to the top surface of the carrier.
6. Pocket position relative to sprocket hole measured as true position of pocket, not pocket hole.
7. Pocket center and pocket hole center must be same position.

Recommended solder pad

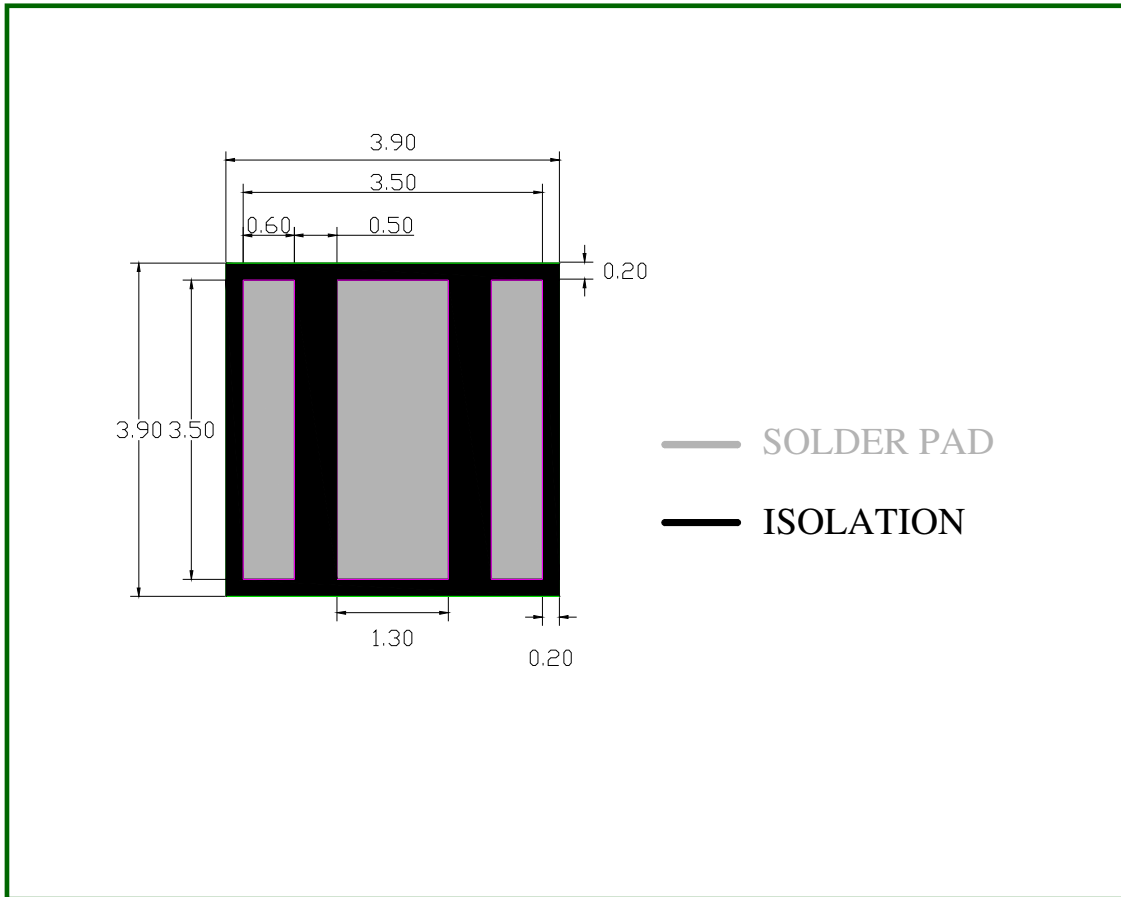

Notes :

- [1] All dimensions are in millimeters.
- [2] Scale : none
- [3] This drawing without tolerances are for reference only

Reflow Soldering Conditions / Profile

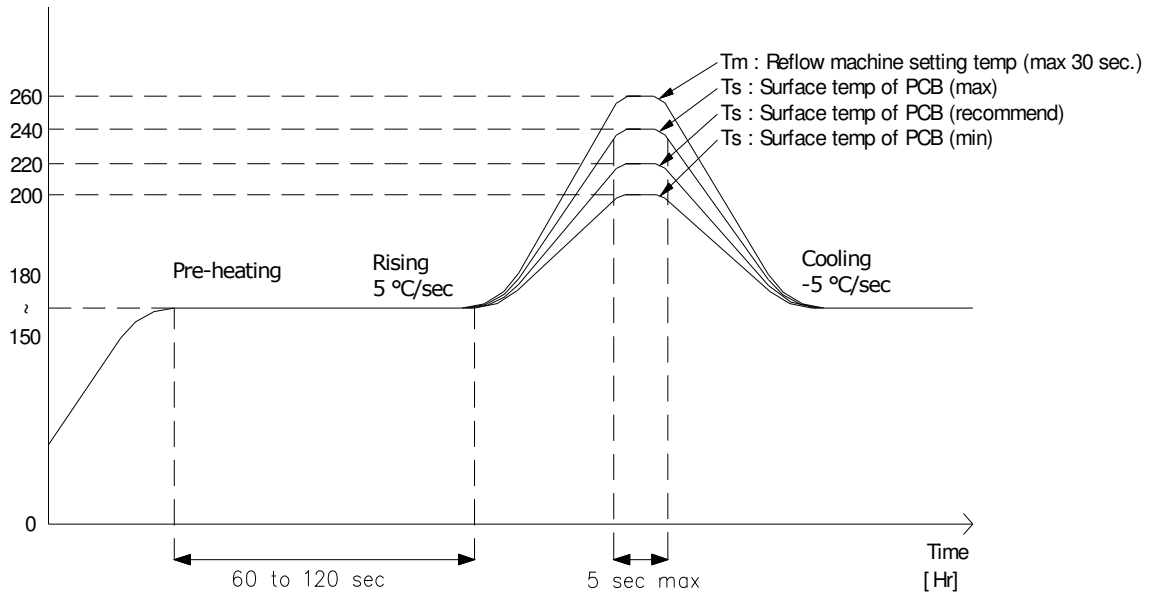

*** Caution**

1. Reflow soldering should not be done more than one time.
2. Repairs should not be done after the LEDs have been soldered. When repair is unavoidable, suitable tools must be used.
3. Die slug is to be soldered.
4. When soldering, do not put stress on the LEDs during heating.
5. After soldering, do not warp the circuit board.
6. Recommend to use a convection type reflow machine with 7 ~ 8 zones.

Precaution for use

- Storage
 - To avoid the moisture penetration, we recommend storing Z Power LEDs in a dry box with a desiccant . The recommended storage temperature range is 5C to 30C and a maximum humidity of 50%.
- Use Precaution after Opening the Packaging
 - Use proper SMD techniques when the LED is to be soldered dipped as separation of the lens may affect the light output efficiency.
 - Pay attention to the following:
 - a. Soldering should be done immediately after opening the package (within 24Hrs).
 - b. Required conditions after opening the package
 - Sealing
 - Temperature : 5 ~ 40°C Humidity : less than 30%
 - c. If the package has been opened more than 1 week or the color of the desiccant changes, components should be dried for 10-12hr at 60±5°C
- Do not apply mechanical force or excess vibration during the cooling process to normal temperature after soldering.
- Do not rapidly cool device after soldering.
- Components should not be mounted on warped (non coplanar) portion of PCB.
- Radioactive exposure is not considered for the products listed here in.
- Gallium arsenide is used in some of the products listed in this publication. These products are dangerous if they are burned or shredded in the process of disposal. It is also dangerous to drink the liquid or inhale the gas generated by such products when chemically disposed of.
- This device should not be used in any type of fluid such as water, oil, organic solvent and etc. When washing is required, IPA (Isopropyl Alcohol) should be used.
- When the LEDs are in operation the maximum current should be decided after measuring the package temperature.
- LEDs must be stored properly to maintain the device. If the LEDs are stored for 3 months or more after being shipped from SSC, a sealed container with a nitrogen atmosphere should be used for storage.
- The appearance and specifications of the product may be modified for improvement without notice.
- Long time exposure of sunlight or occasional UV exposure will cause lens discoloration.
- The slug is isolated from anode electrically.
 - Therefore, we recommend that you don't isolate the heat sink.
- Attaching LEDs, do not use adhesives that outgas organic vapor.

Handling of Silicone resin LEDs

The Z-Power LED is encapsulated with a silicone resin for the highest flux efficiency.

Notes for handling:

- Avoid touching silicone resin parts especially with sharp tools such as Pincette (Tweezers)
- Avoid leaving fingerprints on silicone resin parts.
- Silicone resin will attract dust so use covered containers for storage.
- When populating boards in SMT production, there are basically no restrictions regarding the form of the pick and place nozzle, except that excessive mechanical pressure on the surface of the resin must be prevented.
- It is not recommend to cover the silicone resin of the LEDs with other resin (epoxy, urethane, etc)